

ABB MEASUREMENT & ANALYTICS | DATA SHEET

# PxS100, PxF100, PxD100, PxD100

## Gauge and absolute pressure transmitters



---

# Measurement made easy

Engineered solutions for all applications

## Standard overload resistance

### Base accuracy

- From  $\pm 0.25\%$  up to  $\pm 0.075\%$  of calibrated span

### Span limits

- 0,3 – 10000 kPa; 16 inH<sub>2</sub>O up to 1450 psi
- 0,3 – 10000 kPa abs; 30 mmHg up to 1450 psia

## Proven sensor technology together with state-of-the-art digital technology

- Valuable turn down ratio of up to 100:1

## Stainless steel housing

- Optimized for use in industrial process environments
- Extremely robust

## New touch keypad technology

- allows quick and easy local configuration without opening the cover, even in hazardous classified locations
- backlit display

## Flexible configuration options

- Local configuration via setup button for upper and lower range values
- Local configuration via buttons on HMI
- Via handheld terminal or PC user interface

## PED compliance

- Category III for PS > 20 MPa, 200 bar
- Sound Engineering Practice (SEP) for PS  $\leq$  20 MPa, 200 bar

## Product in compliance with Directive 2011/65/UE (RoHS II)

## Digital Advanced Diagnostics feature

## General Description

### PxS100

Model PxS100 is the compact, reliable, essential pressure transmitter suitable for liquid, gas or steam applications. It is a straightforward and robust device designed for rapid delivery and easy installation and use. Thanks to its rugged design offering high resistance in even the most demanding environments, it is a competitive solution for most applications, including ones in hazardous areas.



Picture 1 - PxS100 with standard process connection

### PxF100

Model PxF100 is designed to fit sanitary, food & beverage processes while providing value on what matters the most. Its compact stainless steel housing grants robustness, resistance to humidity and vibration, while incorporating the high visibility display with backlight option. The intuitive touch HMI is enhanced by the Easy Set up feature, a firmware option to easily configure device parameters from the display itself.



Picture 2 - PxF100 with hygienic Tri-Clamp process connection

### PxD100

Model PxD100 is the pressure transmitter from the Pxx100 series featuring the S26 diaphragm seal line accessories. While having a compact, sturdy stainless-steel housing to grant robustness, resistance to humidity and vibration, PxD100 is leveraging flanges and connections in a variety of geometries. The combination of S26 diaphragm seals design according to ASME/EN standards with the unique ABB All-Welded technology eliminates leakage risks during operation while ensuring perfect fit to any process.



Picture 3 - PxD100 with remote diaphragm seal type S26Rx

### PxP100

Model PxP100 is the new pressure transmitter from ABB featuring various Pulp & Paper process connections. Its compact stainless steel housing grants robustness, resistance to harsh environment, humidity and vibration, while incorporating the high visibility display with backlight option. A combination of dedicated Pulp & Paper process connections with unique wetted parts materials like Hastelloy-C and Diaflex, are available through a well-known and proved ABB seal type.



Picture 4 - PxP100 with Pulp&Paper process connection seal type S26KN

## Specification - Physical<sup>(1)</sup>

### Materials

#### Process isolating diaphragms <sup>(2)</sup>

AISI 316 L ss, Hastelloy C276,  
Diaflex (antiabrasion), H-Shield (against hydrogen permeation)

#### Process connection <sup>(2)</sup>

AISI 316 L ss  
Hastelloy C276 (Available on request)

#### Filling fluids <sup>(3)</sup>

Silicone oil, inert fill (fluorocarbon), Mineral oil (FDA approved), Vegetal oil (FDA approved)

#### Mounting bracket

AISI 304 ss

#### Sensor housing, electronics housing and cover

AISI 316 L ss

#### Filter for atmospheric ventilation

- Filter material: polyamide (PA)
- Filter housing: plastic (general purpose version), stainless steel (Ex certified versions)

#### Cover O-ring

EPDM for sensor O-ring and cover O-ring to glass;  
EPDM for cover O-ring to housing  
Silicon for cover O-ring to housing

#### Process connection O-ring

EPDM for front bonded connection on PXS100  
EPDM, FKM or HNBR for universal connection on PxF100

#### Plates

Nameplate, certification (if applicable) and tag (if requested) labels self-adhesive attached to the electronics housing.

#### Calibration

- Standard: 0 to upper range limit (URL)
- Optional: to specified measuring span

### Optional extras

#### Mounting bracket (code BU)

Universal for vertical and horizontal 60 mm (2 in) pipes or wall mounting

#### Display (code Dx)

Glass Touch is embedded on Device's Display  
Display can be rotated in 5° increments into 72 positions (suggested ± 180° clockwise/anticlockwise rotation)

#### Additional plate

Self-adhesive label for tag and/or calibration details (up to 20 characters). Only by ordering option **code SC** for tag purposes, tag value will both be transferred in the memory of the instrument itself and appear on the optional certificates. Please be aware that display will only show last 8 digits of tag number.

AISI 316 ss wired-on plate with laser printed customized data (4 lines of 32 characters 4 mm/0.16 in high). By ordering option **code LEW**, custom text has to be provided. In case of no text provided, wired-on plate will be delivered blank.

Be aware that if tag is only indicated as part of the custom text, it will neither be transferred in the memory of the instrument itself nor appear on the relevant certificate. If that is required, please order option code SC.

#### Cleaning procedure for oxygen service (code P1)

Oxygen service cleaning, (only available with inert oil fill)  
Pmax =10 MPa for Galden; Tmax=60 °C/140 °F or max. working pressure

#### Certificates (test, design, characteristics, material traceability) (code Cx)

Option code CF provides an inspection certificate of calibration 0 to URL but code "SC" should be also selected if the inspection certificate is required for calibration different from 0 to URL.

#### Approvals (code Gx)

For details refer to section Specification - Certifications and Approvals

#### Operating instruction language (code Mx)

Available in multiple languages

#### Weight

- Approx. 950-2500g (2.1-5.5lb)
- For PXS100 additional 200 g (0.44 lb) for packaging
- For PxF100 and PXS100 with M26 additional 400 g (0.88 lb) for packaging
- For PxD100 weight might vary depending on the selected S26 model

#### Packaging

- Carton with dimensions of approx. 180 x 160 x 130 mm (7.1 x 6.3 x 5.1 in) (PXS100 models)
- Carton with dimensions of approx. 270 x 235 x 185 mm (10.6 x 9.25 x 7.3 in) (For PxF100, PXP100 and PXS100 with M26)
- For PxD100 carton dimension might vary depending on the selected S26 model

(1) Refer to the ordering information for availability of different versions of the relevant models

(2) Wetted parts of the transmitter.

(3) In case of PxD refer to [OI/DS-S26](#) datasheet for additional information on other available filling fluids

## Functional – specification

### Range and span limits

Sensor code	Upper range limit (URL)	Lower range limit (LRL)	Minimum measuring span	
			Model PGx100 Gauge pressure	Model PAX100 Absolute pressure
C	6 kPa	-6 kPa	0.3 kPa	0.3 kPa
	60 mbar	-60 mbar	3 mbar	3 mbar
	24 inH2O	-24 inH2O	1.2 inH2O	2.25 mmHg
F	40 kPa	-40 kPa	2 kPa	2 kPa
	400 mbar	-400 mbar	20 mbar	20 mbar
	160 inH2O	-160 inH2O	8 inH2O	15 mmHg
L	250 kPa	-100 kPa	12.5 kPa	12.5 kPa
	2500 mbar	-1 bar	125 mbar	125 mbar
	36.26 psi	-14.5 psi	1.81 psi	93.3 mm Hg
D	1000 kPa	-100 kPa	50 kPa	50 kPa
	10 bar	-1 bar	0.5 bar	0.5 bar
	145 psi	-14.5 psi	7.25 psi	375 mmHg
K	4000 kPa	-100 kPa	200 kPa	200 kPa
	40 bar	-1 bar	2 bar	2 bar
	580 psi	-14.5 psi	29 psi	29 psi
R	10000 kPa	-100 kPa	500 kPa	500 kPa
	100 bar	-1 bar	5 bar	5 bar
	1450 psi	-14.5 psi	72.5 psi	72.5 psi

#### IMPORTANT (NOTE)

The lower range limits (LRL) for models PAX100 are 0 absolute for all measuring ranges.

### Span limits

Maximum span = upper range limit (URL)

To optimize performance characteristics, it is recommended that you select the transmitter sensor code providing the lowest turn down ratio.

TURNDOWN = Upper range limit / set span

### Zero suppression and elevation

Zero and span can be adjusted to any value within the range limits detailed in the table as long as:

– calibrated span ≥ minimum span

### Damping

Configurable time constant between 0 and 60 s.

This is in addition to the sensor response time, and can be adjusted via the optional display, handheld terminal, or PC user interface.

### Warm-up time

Ready for operation as per specifications in less than 10 s with minimum damping.

### Insulation resistance

>100 MΩ at 500 V DC (between terminals and ground, according to EN61010-1 and EN62828-1 par 6.2.3.2).

## Specification – Operative limits

### Pressure limits

#### Overpressure limits

Without damage to the transmitter

No damage will occur during transmitter operation, if they are used within the specifications and subject to the following limits:

Sensor code	Overpressure limits, 0 abs to:
C , F	1 MPa, 10 bar, 145 psi
L	3 MPa, 30 bar, 435 psi
D	6 MPa, 60 bar, 870 psi
K	8 MPa, 80 bar, 1160 psi
R	20 MPa, 200 bar, 2900 psi

The below table shows the maximum pressure limits of the connection when coupled with customer process interface. It also shows the compatibility of the sensor ranges.

Model Px F100 Sensors	Seal type	Pressure limit
Sensors L to R	Universal G1" hygienic - AISI	6 MPa, 60 bar, 870 psi
	Universal G1" hygienic - HC	
	Universal G1" hygienic - Diaflex on AISI	
	Universal G1" hygienic - Diaflex on HC	
	Tri-Clamp (1½")	
All Sensors	Tri-Clamp (1")	4 MPa, 40 bar, 580 psi
	Tri-Clamp (2")	3.8 MPa, 38 bar, 550 psi
	Tri-Clamp (3")	2.4 MPa, 24 bar, 350 psi
	Tri-Clamp (4")	1.7 MPa, 17 bar, 250 psi
	Sensors L to R	DRD 65mm
Diary 11851 DN40		2.5 MPa, 25 bar, 360 psi
Diary 11851 DN50		
SMS 1 ½"		4 MPa, 40 bar, 580 psi
SMS 2"		
All Sensors	Varinline® F DN25	2.5 MPa, 25 bar, 360 psi
	Varinline® N DN40	
	Neumo Biocontrol® GR50	1.6 MPa, 16 bar, 230 psi
	Neumo Biocontrol® GR65	
Sensors L to R	Dairy DIN 11864-1 typeA DN40	4 MPa, 40 bar, 580 psi
	Dairy DIN 11864-1 typeA DN50	2.5 MPa, 25 bar, 360 psi

Model Px P100 Sensors	Seal type	Pressure limit
Sensors L to R	1 in. pulp and paper seal with ball valve connection	4 MPa, 40 bar, 580 psi
	1 in. pulp and paper seal - sealing with gaskets to spud	3 MPa, 30 bar, 435 psi
	1 in. pulp and paper seal with 1 in. NPT male threaded connection	34.5 MPa, 345 bar, 5000 psi
	1 in. pulp and paper seal with G 1 in. A male threaded connection	60 MPa, 600 bar, 8700 psi
	1 1/2 in. pulp and paper seal - sealing with gasket to spud	5 MPa, 50 bar, 725 psi
All Sensors	1 1/2 in. pulp and paper seal with 1 1/2 in. NPT male threaded connection	34.5 MPa, 345 bar, 5000 psi
	1 1/2 in. pulp and paper seal with G 1 1/2 in. A male threaded connection	60 MPa, 600 bar, 8700 psi
	1 1/2 in. pulp and paper seal - sealing with gasket to M44 threaded spud	-

Seal model (Standard)	Seal diaphragm size (thickness) / flange type	Max. pressure	Note
S26WA (ASME B16.5)	All dimensions and types	up to 41.37 MPa, 413.7 bar, 6000 psi	but not greater than rating of mounting flange (NOT SUPPLIED)
	Form B1	40 Mpa, 400 bar, 5800 psi	but not greater than rating of mounting flange (NOT SUPPLIED)
S26WE (EN 1092-1)	Form D	16 MPa, 160 bar 2320 psi	
	Form E	10 MPa, 100 bar, 1450 psi	

Seal model (Standard)	Seal diaphragm size (thickness) / flange type	"Max. pressure Carbon Steel @ 100 °F (38 °C)"	"Max. pressure AISI 316 ss flange @ 100 °F (38 °C)"
S26RA (ASME B16.5)	Class 150	2 Mpa, 20 bar, 285 psi	1.9 Mpa, 19 bar, 275 psi
	Class 300	5.1 Mpa, 51 bar, 740 psi	5 Mpa, 50 bar, 720 psi
	Class 600	10.2 Mpa, 102 bar, 1480 psi	9.9 Mpa, 99 bar, 1440 psi
	Class 900	15.3 Mpa, 153 bar, 2220 psi	14.9 Mpa, 149 bar, 2160 psi
	Class 1500	25.5 Mpa, 255 bar, 3705 psi	24.8 Mpa, 248 bar, 3600 psi
	Class 2500	42,5Mpa, 245 bar, 6170 psi	41,4 Mpa, 414 bar, 6000 psi

Seal model (Standard)	Seal diaphragm size (thickness) / flange type	"Max. pressure Carbon steel flange @ 120 °C"	"Max. pressure AISI 316 ss flange @ 20 °C"
S26RE (EN 1092-1))	PN 16	1.6 Mpa, 16 bar, 230 psi	1.6 Mpa, 16 bar, 230 psi
	PN 40	4 Mpa, 40 bar, 580 psi	4 Mpa, 40 bar, 580 psi
	PN 63	6.3 Mpa, 63 bar, 910 psi	6.3 Mpa, 63 bar, 910 psi
	PN 100	10 Mpa, 100 bar, 1450 psi	10 Mpa, 100 bar, 1450 psi

Seal model (Standard)	Seal diaphragm size (thickness) / flange type	"Max. pressure AISI 316 L ss flange @ 100 °F (38 °C)"
S26FA (ASME B16.5)	Class 150	1.6 Mpa, 16 bar, 230 psi
	Class 300	4.1 Mpa, 41 bar, 600 psi
	Class 600	8.3 Mpa, 83 bar, 1200 psi

Seal model (Standard)	Seal diaphragm size (thickness) / flange type	"Max. pressure AISI 316 L ss flange @ 20 °C"
S26FE (EN 1092-1))	PN 16	1.6 Mpa, 16 bar, 230 psi
	PN 40	4 Mpa, 40 bar, 580 psi
	PN 63	6.3 Mpa, 63 bar, 910 psi
	PN 100	10 Mpa, 100 bar, 1450 psi

The pressure limit decreases with increasing temperature above to the specified values as defined for the material for both ASME B16.5 and EN 1092-1 standards.

**Test pressure**

When carrying out the transmitter pressure test, it is essential to observe the overpressure limits.

**Temperature limits °C (°F)**

**Ambient**

Model PGx100, PAx100	Ambient temperature limits
Operating temperature range	-40 and 85 °C (-40 and 185 °F)
LCD display readability	-20 and 70 °C (-4 and 158 °F)

**Process**

Model PGx100, PAx100	Process temperature limits
Process temperature range	-50 and 120 °C (-58 and 248 °F)
EPDM gasket for G 1/2 in. FB	-45 and 120 °C (-49 and 248 °F)

Model PGD100, PAD100	Process temperature limits
Process temperature range	Please refer to process temperature limits driven by S26 remote seals

Model PGF100, PAF100	Process temperature limits
Process temperature range	-50 and 180 °C (-58 and 356 °F)*
EPDM gasket for universal connection	-50 and 150 °C (-58 and 302 °F)
FKM for gasket for universal connection	-20 and 200 °C (-4 and 392° F)
HNBR for gasket for universal connection)	-40 and 180 °C (-40 and 356° F)

\* Upper process temperature limit is valid considering an ambient temperature up to +50 °C (122 °F). In case of ambient temperature up to +85 °C (185 °F) upper process temperature limit is 150 °C (302 °F)

Model PGP100, PAP100	Process temperature limits
Process temperature range	-50 and 180 °C (-58 and 356 °F)**

\*\* In case of 1 in. pulp and paper seal with ball valve connection (Digit E) the limits reduce up to -20 and 130 °C

Upper and lower process temperature limits of the transmitter can vary or be lower according to the physical characteristics of the filling fluid and to the selected gasket type. Please always consider the most stringent condition as applicable operative limit.

**Storage**

Model PGx100, PAx100	Storage temperature limits
Storage temperature range	-50 and 85 °C (-58 and 185 °F)
LCD display	-40 and 85 °C (-40 and 185 °F)

Model PGx100, PAx100	Humidity during storage
Relative humidity	Up to 75 %

**IMPORTANT (NOTE)**

For Hazardous Atmosphere and Ordinary location applications see the temperature range specified on the certificate/ approval relevant to the aimed type of protection.

## ...Specification – Operative limits

Refer to the following FILL FLUID CHARACTERISTICS table detailing characteristics of fill fluids when used in transmitters. Operational limits may vary depending on the materials, gasket and configuration selected.

Fill fluid (application)	Models				Process temperature and pressure limits				Specifications @ 25 °C (77°F)		
	PxS100	PxF100	PxD100	PxP100	Tmax °C (°F) @ Pabs > of	Pmin mbar abs (mmHg)	Tmax °C (°F) @ Pmin	Tmin °C (°F)	Specific gravity (kg/dm <sup>3</sup> )	Kinematic viscosity (cst)	Thermal expansion (x 10 <sup>-3</sup> /°C)
Silicone oil PMX 200 10 cSt	-	Y	Y	Y	250 (480) @ 385 mbar	0.7 (0.5)	130 (266)	-40 (-40)	0.934	10	1.08
Silicone oil Baysilone PD5 5 cSt	Y	-	Y	-	250 (480) @ 900 mbar	0.7 (0.5)	45 (113)	-85 (-121)	0.923	5	0.98
Inert oil Galden G5 (oxygen service)	Y	Y	Y	Y	160 (320) @ 1 bar	2.1 (1.52)	60 (140)	-20 (-4)	1.82	4.4	1.1
Silicone polymer Syltherm XLT (cryogenic service)	-	-	Y	-	100 (212) @ 118 mbar	2.1 (1.52)	20 (68)	-100 (-148)	0.852	1.4	1
Silicone oil for high temperature (for REMOTE SEAL)	-	-	Y	-	375 (707) @ 1 bar	0.7 (0.5)	220 (428)	-10 (14)	1.07	39	0.77
Silicone oil for high temperature (for DIRECT MOUNT SEAL)	-	-	Y	-	250 (480) @ 3.5 mbar	0.7 (0.5)	220 (428)	-10 (14)	1.07	39	0.77
Vegetable oil Neobee M-20 (food - sanitary) FDA approved	-	Y	Y	-	200 (390) @ 1 bar	10 (7.2)	20 (68)	-18 (0)	0.92	9.8	1.2
Mineral oil Esso Marcol 152 (food - sanitary) FDA approved	-	Y	Y	-	250 (480) @ 630 mbar	0.7 (0.5)	110 (230)	-6 (21)	0.86	30	0.80
Mineral oil Esso Marcol 82 (food - sanitary) FDA approved -	Y	-	-	-	200 (390) @ 200mbar	33 (0.5)	40 (104)	-6 (21,2)	0,84	26	1.04
Glycerin Water 70% (food - sanitary) FDA approved	-	-	Y	-	93 (200) @ 1 bar	1000 (760)	93 (200)	-7 (20)	1.08	2	0.36

Absolute viscosity (cP) = Kinematic Viscosity (cSt) x Specific gravity at specified temperature.  
The absolute viscosity value is used for response time calculation.



### Model PGD100, PAD100 Seal system selection criteria

The following table shows the types of seals available as direct mount and remote.

According to the combination SEAL/TRANSMITTER SENSOR the table details the compatibility for one direct mount seal construction and the MAXIMUM CAPILLARY LENGTH when a seal is selected as remote.

The mnemonics will be used as shortest cross references in the S26 data sheet.

Seal model	Seal type	"Seal diaphragm size (thickness) [flange type]"	Direct mount seal						Remote seal						Mnemonic	
			Sensor						Sensor							
			C	F	L	D	K	R	C	F	L	D	K	R		
S26WA S26WE	Wafer (ASME and EN standards)	1.5 in / DN 40	-	-	-	-	-	-	-	-	3	5	5	5	P1.5	
		2 in / DN 50	-	-	-	-	-	-	-	2	6	8	8	8	P2	
		3 in / DN 80	-	-	-	-	-	-	-	4	10	10	10	10	P3	
		1.5 in / DN 40 (low)	-	-	-	-	-	-	-	-	3	6	6	6	F1.5	
		2 in / DN 50 (low)	-	-	-	-	-	-	-	3	8	6	16	16	F2	
		3 in / DN 80 (low)	-	-	-	-	-	-	-	6	10	12	16	16	F3	
S26FA S26FE S26RA S26RE	Flanged flush diaphragm (ASME and EN standards)	DN 25	-	-	Y	Y	Y	Y	-	-	-	-	-	-	F1	
		DN 25 (recessed diaphragm)	-	-	Y	Y	Y	Y	-	-	-	-	-	-	T2	
		2 in / DN 50	Y	Y	Y	Y	Y	Y	-	2	6	8	8	8	P2	
		3 in / DN 80	Y	Y	Y	Y	Y	Y	-	4	10	10	10	10	P3	
		4 in / DN 100	Y	Y	Y	Y	Y	Y	-	4	10	10	10	10	P3	
		2 in / DN 50 (low)	Y	Y	Y	Y	Y	Y	-	3	8	12	16	16	F2	
		3 in / DN 80 (low)	Y	Y	Y	Y	Y	Y	-	6	10	16	16	16	F3	
		4 in / DN 100 (low)	Y	Y	Y	Y	Y	Y	-	6	10	16	16	16	F3	
		Flanged extended diaphragm (ASME and EN standards)	2 in / DN 50	-	-	Y	Y	Y	Y	-	-	4	6	6	6	E2
			3 in / DN 80	Y	Y	Y	Y	Y	Y	-	4	8	10	10	10	E3
			4 in / DN 100	Y	Y	Y	Y	Y	Y	-	4	10	10	10	10	P3
			2 in / DN 50 [fixed]	-	-	Y	Y	Y	Y	-	-	3	6	6	6	F1.5
3 in / DN 80 [fixed]	Y		Y	Y	Y	Y	Y	-	6	10	12	12	12	F2.5		
		4 in / DN 100 [fixed]	Y	Y	Y	Y	Y	Y	-	6	10	12	12	12	F2.5	

Please see more details on S26 remote seals at this link: [OI/DS-S26](#)

## ...Specification – Operative limits

### Environmental limits

#### Electromagnetic compatibility (EMC)

The devices comply with the requirements and tests for EMC Directive 2014/30/EU to standards EN 61326-1 Table 2 (industrial electromagnetic environment) concerning both emitted interference (CISPR11) and interference immunity.

- Burst test: up to 2 kV at 5 kHz and 100 kHz
- Surge test: up to 1 kV line-line and 2 kV line-ground

Radiated emission: Group 1 - class B according to CISPR11

- FCC 47 CFR part 18.305
- ICES 005 - Issue 4

Conducted emission: group 1 - class A according to CISPR11 and to CISPR32

- ICES 005 - Issue 4

#### Pressure equipment directive (PED)

Comply with 2014/68/EU to standards ANSI/ISA S82.03

- Category III Module H for PS > than 20 MPa, 200 bar
- Sound Engineering Practice (SEP) for PS ≤ 20 MPa, 200 bar.

#### Humidity

Relative humidity: up to 100 %

Condensation, icing: permissible

#### Vibration resistance

Acceleration at frequencies of

- 10 – 60 Hz with displacement of 0.7 mm
- 60 – 1000 Hz 5 g (50 m/s<sup>2</sup>)

(according to IEC 60068-2-6).

#### Shock resistance

Test Ea Half sine with 3 positive and 3 negative shocks for each axis

- Acceleration: 50 g
- Duration: 11 ms

Continuous test Ea half sine with 1000 positive and 1000 negative shocks for each axis

- Acceleration: 10 g
- Duration: 10 ms

(according to IEC 60068-2-27)

#### Wet and dust-laden atmospheres (IP degree of protection)

The transmitter is dust and sand-tight, and is protected against immersion effects as defined by the following standards:

- IEC EN60529 to IP66, IP67, IP68
- ISO 20653 to IP69K
- NEMA 4X

#### Tested ambient

The transmitter is suitable for class D1, non weather-protected locations, outdoor locations (according to IEC 60654-1)

## Specification - Performance

Reference conditions according to IEC 62828-1

- Ambient temperature constant in the range 15 – 25 °C (59 – 77 °F)
- Relative humidity constant in the range 50 – 70 %
- Ambient pressure constant in the range 860 – 1060 mbar
- Measuring span based on zero position
- Transmitter with AISI 316 L or Hastelloy C276 process isolating diaphragm
- Filling fluid: Silicone oil
- Supply voltage: 24 V DC ± 1 %
- Load with HART: 250 Ω
- Transmitter not grounded
- Characteristic setting: linear, 4 – 20 mA.

Unless otherwise specified, errors are quoted as % of calibrated span.

Some performance referring to the Upper Range Limit are affected by the actual turndown (TD) as ratio between Upper Range Limit (URL) and calibrated span.

FOR OPTIMUM MEASURING ACCURACY, IT IS RECOMMENDED THAT YOU SELECT THE SENSOR CODE WHICH WILL PROVIDE THE LOWEST TD VALUE.

### Dynamic response (according to IEC 61298-2 / IEC 62828-1)

Dead time	90 ms
Time constant (63.2 % of total step response)	100 ms

### Accuracy rating (ELin)

% of calibrated span, including combined effects of terminal based linearity, hysteresis and repeatability.

#### Model PXS100, PxD100

For all sensors	Turndown	Accuracy
Standard accuracy (± 0.25 %)	from 1:1 to 10:1	± 0.25 %
	from 10:1 to 20:1	± 0.25% + 0.01% x TD – 0.1%
Extended accuracy (± 0.10 %) (E9)	from 1:1 to 10:1	± 0.10 %
	from 10:1 to 20:1	± 0.01% x TD
High accuracy (± 0.075%) (E7)	from 1:1 to 5:1	± 0.075 %
	from 5:1 to 20:1	±0.075% + 0.0075% x TD – 0.0375%

#### Model PxF100, PXP100

For all sensors	Turndown	Accuracy
Standard accuracy (± 0.10 %)	from 1:1 to 10:1	± 0.10 %
	from 10:1 to 20:1	± 0.01% x TD
High accuracy (± 0.075%) (E7)	from 1:1 to 5:1	± 0.075 %
	from 5:1 to 20:1	±0.075% + 0.0075% x TD – 0.0375%

Highest factory configurable turn down 20:1, higher values available on request.

### Ambient temperature (EΔTZ+EΔTS)

Temperature effect according to IEC 62828/1

For temperature variation between the limits of –40 °C to +85 °C (-40 °F to +185 °F)

Sensor	for TD up to	
All	20:1	± (0.15 % URL + 0.15 % span)

In case of maximum ambient temperature variation of 28K, then the following expression could be used as it provides a more accurate interpretation of the effect in that interval.

For 28K temperature variation between the limits of –40 °C to +85 °C (-40 °F to +185 °F)

Sensor	for TD up to	
C, F	20:1	± (0.15 % URL + 0.15 % span)
L, D, K, R	20:1	± (0.1 % URL + 0.1 % span)

For PxD100 models, refer to S26 remote seals [OI/DS-S26](#) document for additional error and effects due to ambient temperature changes when in combination with S26x diaphragm seal.

For PxF100 and PXP100 models, in case process temperature is different from ambient temperature an additional diaphragm seal related error (EΔTR) could be present.

Please contact directly ABB for more details.

## ...Specification - Performance

### Power supply

Within the specified limits for the voltage / load, the total influence is less than 0.005 % of the upper measuring range limit per volt.

### Load

Within the specified load / voltage limits, the total influence is negligible.

### Mounting position

Nominal position: vertical; process connection at bottom.

Mounting positions deviant from the standard position influence the output due to the filling liquid.

This effect can be compensated by carrying out zero signal adjustment.

### Long-term stability

± 0.25 % of URL over a 10 years period

### Total performance

For a temperature change from -40° to 85°C (-40° to +185°F) with TD 1:1 and considering IEC 62828-1 expression:

- 0,39 % of calibrated span for standard accuracy models
- 0,32 % of calibrated span for E9 extended accuracy models
- 0,31 % of calibrated span for E7 extended accuracy models

Total performance includes the measuring errors of

- non-linearity including hysteresis and repeatability
- thermal change of the ambient temperature as regards the zero signal and the calibrated span.

$$E_{perf} = \sqrt{(E_{ATZ} + E_{ATS})^2 + E_{Lin}^2}$$

$E_{perf}$  = Total performance

$E_{ATZ}$  = Effect of the ambient temperature on zero

$E_{ATS}$  = Effect of the ambient temperature on span

$E_{Lin}$  = Accuracy rating

For PxF100, PXP100 and PxD100 models, in case process temperature is different from ambient temperature, please consider following expression:

$$E_{perf} = \sqrt{(E_{ATZ} + E_{ATS})^2 + E_{Lin}^2 + E_{ATR}^2}$$

In case the Total Performance calculation would be needed for models not using Silicone oil (PMX 200) the diaphragm seal related error ( $E_{ATR}$ ) shall be multiplied by the ratio between the thermal expansion coefficients of the selected filling divided by the one of PMX 200, listed in the fill fluid characteristics table.

For more details about above Total Performance calculation please contact ABB directly

## Specification - Certifications and Approvals

### Hazardous atmospheres

#### INTRINSIC SAFETY Ex ia:

##### ATEX Europe approval (code HAM)

- II 1 G Ex ia IIC T4 Ga
- II 1/2 D Ex ia IIIC T 135°C Da/Db
- II 1/2 D Ex ta/tb IIIC T 135°C Da/Db

##### IECEX approval (code HJM)

- Ex ia IIC T4 Ga
- Ex ia IIIC T 135°C Da/Db
- Ex ta/tb IIIC T 135°C Da/Db

##### CSA Approvals (code HCM)

- For US
  - Class I, Zone 0, AEx ia IIC T4 Ga
  - IS Class I Div 1 Gr A, B, C, D T4
  - IS Class II, Div 1 Gr E, F, G 120° C
  - Zone 20/21 AEx ia IIIC T135° C Da/Db
  - Zone 20/21 AEx ta/tb IIIC T135° C Da/Db
  - Class I, Div. 2 Gr A, B, C, D T4
  - Class III, Div 1
- For Canada
  - Ex ia IIC T4 Ga
  - IS Class I Div 1 Gr A, B, C, D T4
  - IS Class II, Div 1 Gr E, F, G 120° C
  - Ex ia IIIC T135°C Da/Db
  - Ex ta/tb IIIC T135°C Da/Db
  - Class I, Div. 2 Gr A, B, C, D T4
  - Class III, Div 1

##### Combined ATEX Europe, IECEX and CSA (US and Canada) approvals (code HMM)

Without integral display

##### NEPSI China approval (code HMN)

Without integral display

- INTRINSIC SAFETY Ex ia:
  - Ex ia IIC T4 Ga
  - Ex iaD 20/21 T135°C
  - Ex tD A20/A21 IP6X T135°C

With integral display

##### NEPSI China approval (code HMN)

With integral display

- INTRINSIC SAFETY Ex ia:
  - Ex ia IIC T4 Ga

### IMPORTANT (NOTE)

REFER TO CERTIFICATES FOR PROTECTION CONCEPT, PROCESS TEMPERATURE RANGES AND MAX AMBIENT TEMPERATURE.

### Other Approvals

#### Ministerial decree DM174/2004

Wetted parts in AISI 316 L for Pxs100 are approved under ministerial decree nr. DM174/2004 and hence are suitable for drinking water applications.



#### Water Regulation Approval Scheme (WRAS)

Pxs100 with wetted parts in AISI 316 L is WRAS approved and hence suitable for drinking water applications when installed and used correctly.



#### Hygienic Equipment Design of the EHEDG (PxF100)

PxF100 process connections have been certified according to the EHEDG guidelines and hence are suitable, with appropriate filling fluids, gaskets and installation guidance, for Food and Beverage applications.



#### Conforming to 3-A Sanitary Standards (PxF100)

PxF100 process connections (with both diaphragm materials AISI 316 L and Hastelloy® C-276) have been certified according to the 3-A guidelines and hence are suitable, with appropriate filling fluids, gaskets and installation guidance, for Food and Beverage applications. ABB is authorised to display the 3-A Symbol.



#### European Regulation (EC) No. 1935/2004

Pxx100 uses wetted parts which are in compliance with (EC) No. 1935/2004, see available declaration on [www.abb.com/pressure](http://www.abb.com/pressure)

## Specification - Electrical data and options

### HART digital communication and 4 to 20 mA output

#### Power supply

The transmitter operates from 10.5 to 42 V DC with no load and is protected against reversed polarity (additional loads enable operation above 42 V DC).

Minimum operating voltage increases to 14.5 V DC with optional backlit LCD display.

For Ex ia and other intrinsically safe approval power supply must not exceed 30 V DC.

#### Ripple

Maximum permissible supply voltage ripple during communication complies with HART FSK "Physical Layer" specification rev. 8.1.

#### Load limitations

Total loop resistance at 4 to 20 mA and HART:

$$R \text{ (k}\Omega\text{)} = \frac{\text{Voltage supply} - \text{Minimum operating voltage (VDC)}}{22 \text{ mA}}$$

A minimum resistance of 250  $\Omega$  is required for HART communication.

#### LCD display (optional)

##### 2 versions available-

- D3: Glass touch LCD display with 2-button keypad
- D4: Backlit glass touch LCD display with 2-button keypad

Digital, graphic LCD display with 2-button keypad for customized visualization and configuration

VISUALISATION	Analog version (4-20 mA)	HART version (4-20 mA + HART)
PV value (in Pressure units)	-	Y
Output current in mA and %	Y	Y
HART outputs <sup>(1)</sup>	-	Y
Diagnostic messages, alarms, errors	-	Y
Measuring range limits violations	-	Y
QR code diagnostics <sup>(2)</sup>	-	Optional

CONFIGURATION	Analog version (4-20 mA)	HART version (4-20 mA + HART)
Zero and Span (20 mA) using 2 buttons <sup>(3)</sup>	Y	Y
Easy setup configuration Menu <sup>(4)</sup>	Optional	Y

<sup>(1)</sup> Freely assigned start/end values and unit

<sup>(2)</sup> Optional through SD digit code

<sup>(3)</sup> Applied pressure is required

<sup>(4)</sup> Optional through SE digit code

#### Output signal

4 to 20 mA analog version

- Two-wire, 4 to 20 mA analog output signal

HART/4 to 20 mA version

- Two-wire, 4 to 20 mA analog output signal and digital process variables (% , mA or engineering units) superimposed on the 4 to 20 mA signal with protocol based to Bell 202 FSK standard H.

#### Output current limits for 4 to 20 mA analog version

Overload condition

- Lower limit: 3.8 mA
- Upper limit: 20.5 mA

Default alarm current

- 21 mA

#### Output current limits for HART/4 to 20 mA version (according to NAMUR NE 43 standard)

Overload condition

- Lower limit: 3.8 mA (settable from 3.8 to 4 mA)
- Upper limit: 20.5 mA (settable from 20 to 21 mA)

Alarm current

- Lower alarm value: 3.6 mA (settable from 3.6 to 4 mA)
- High alarm value: 21 mA (settable from 20 to 22.8 mA)

Default setting: high alarm current

NAMUR NE 43 defines as alarm limits the lower  $\leq 3.6$  mA and the upper  $\geq 21$  mA.

Risk connected to any deviation from NAMUR NE43 thresholds of the alarm current limits falls under Customers' responsibility.

#### HART release

Revision 7.

## Configuration

### Transmitter with HART communication and 4 – 20 mA

#### Standard configuration

Transmitters can be ordered optionally factory calibrated to customers specific range. The required calibrated range and tag will be printed on an additional tag plate. If a calibration range and tag is not required, the transmitter will be supplies as follows:

Engineering Unit	kPa
4 mA	Zero
20 mA	Upper Range Limit (URL)
Output	Linear
Damping	1 s
Transmitter failure mode	Upscale
Tag	Blank (up to 20 alphanumeric characters - long; only last 8 visible on display - short)
Optional display	2 line display view: - PV in kPa for HART version, in mA for 4 to 20 mA version; - output in mA and in percent as bargraph
Write protection	Disabled

Any or all the above configurable parameters, including lower and upper range values which must be the same unit of measure, can be easily changed using a HART hand-held communicator or by a PC running the configuration software with DD or FDI

#### Tag and Calibration

Tag and/or specific calibrated span shall be ordered using option code SC.

In case a calibration report is needed on a full range device, option code SC has to be ordered and full span has to be provided as calibrated span.

In case option SC is ordered for tag purposes, two tag types are available: Short Tag and Long Tag.

See below table for details about tag type applicability / presence:

Type	Max Length	On Display	On Certification	On Device Label
Short Tag	8 digits	YES	YES	NO
Long Tag	32 digits	NO	YES	YES

In order to enable Tag (either Long / Short or both) option SC is mandatory in the code

In case no specific indication will be given about the tag type, data will be considered as Long Tag by default.

In case tag is required on the optional wired-on customer data plate (optional digit LEW) specific indication needs to be given.

## Mounting dimensions

(not design data) - dimensions in mm (inch)

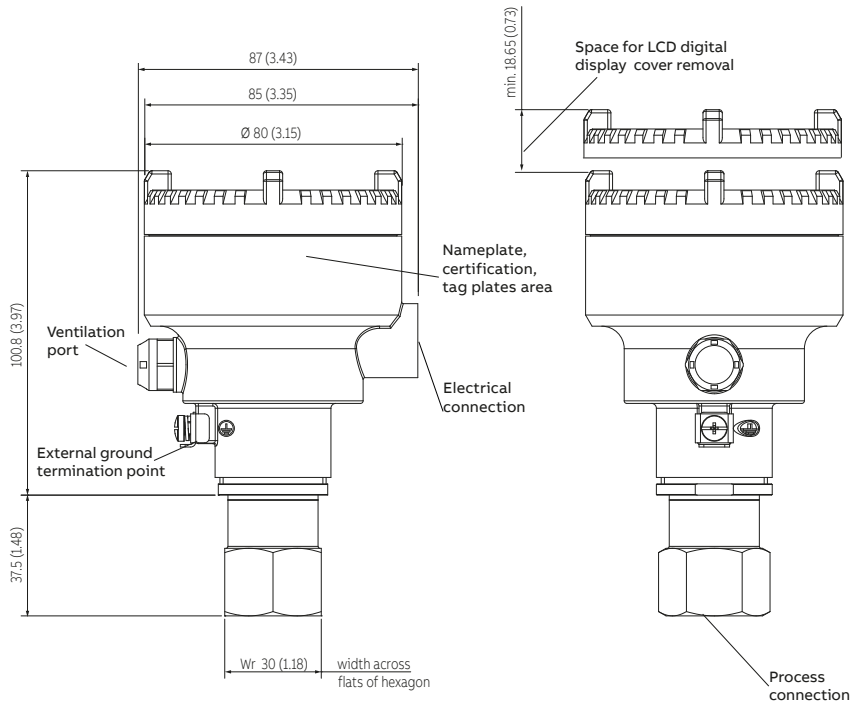

Figure 1 PXS100 with 1/2 in NPT female connection (Option code "A")

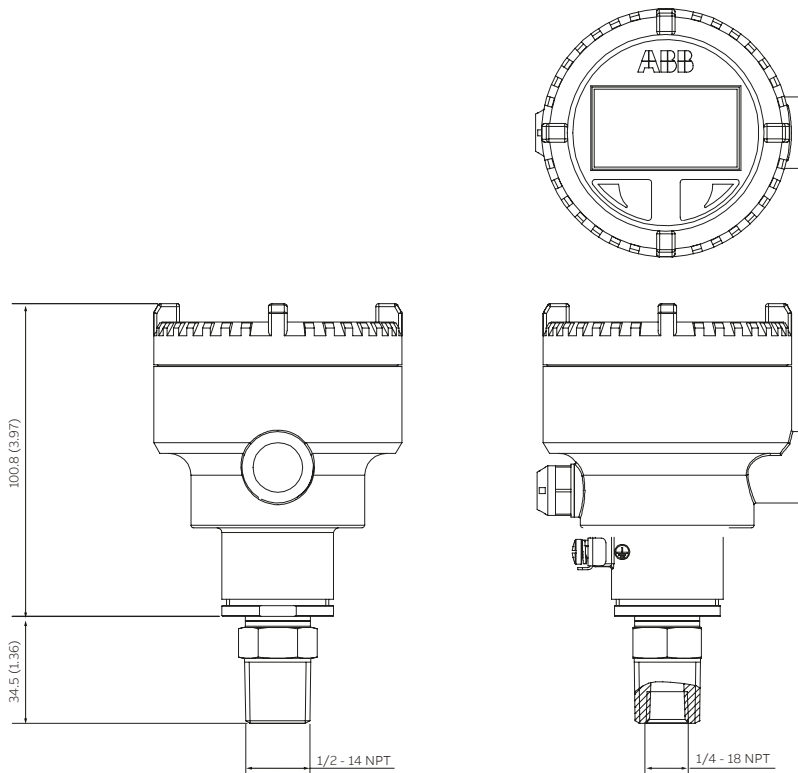

Figure 2 PXS100 with 1/2 in NPT male / 1/4 in NPT female connection and LCD digital display (Option code "B")



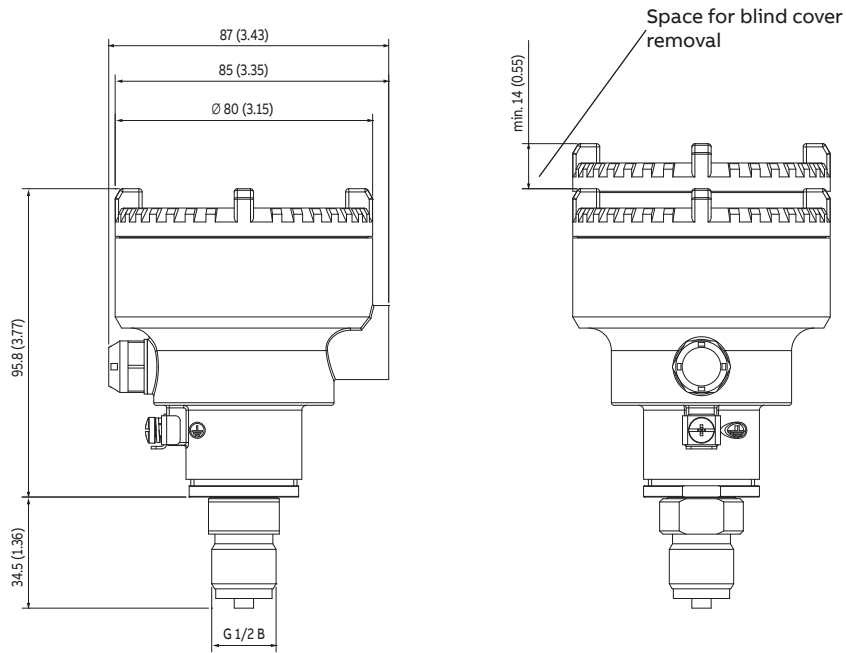

Figure 3 PXS100 with DIN-EN837-1 G 1/2 B connection (Option code "C")

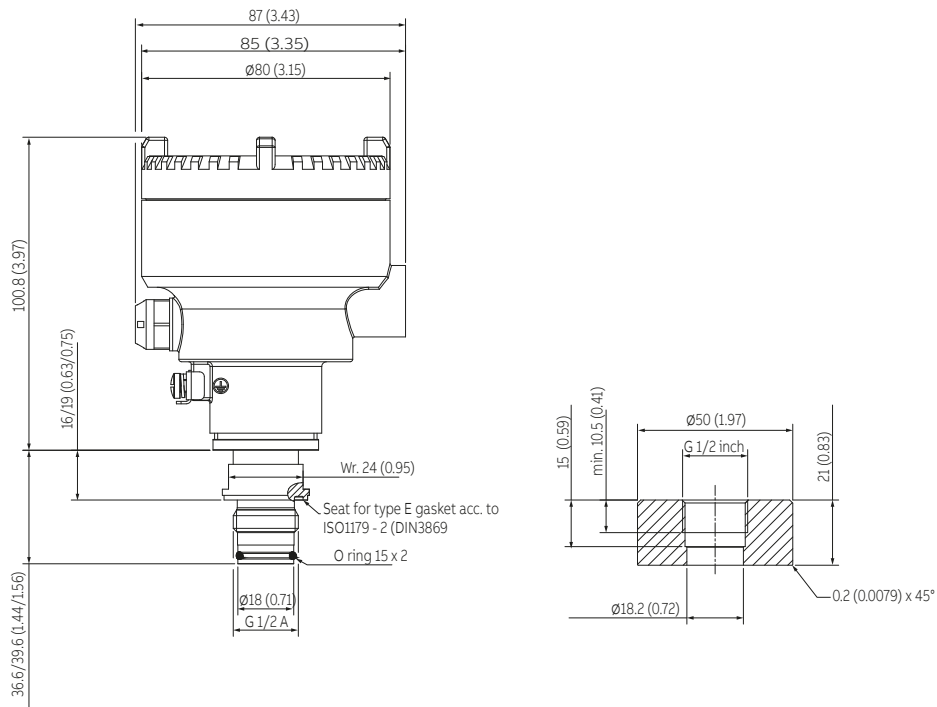

Figure 4 PXS100 with front bonded diaphragm connection (Option code "P")

### ...Mounting dimensions

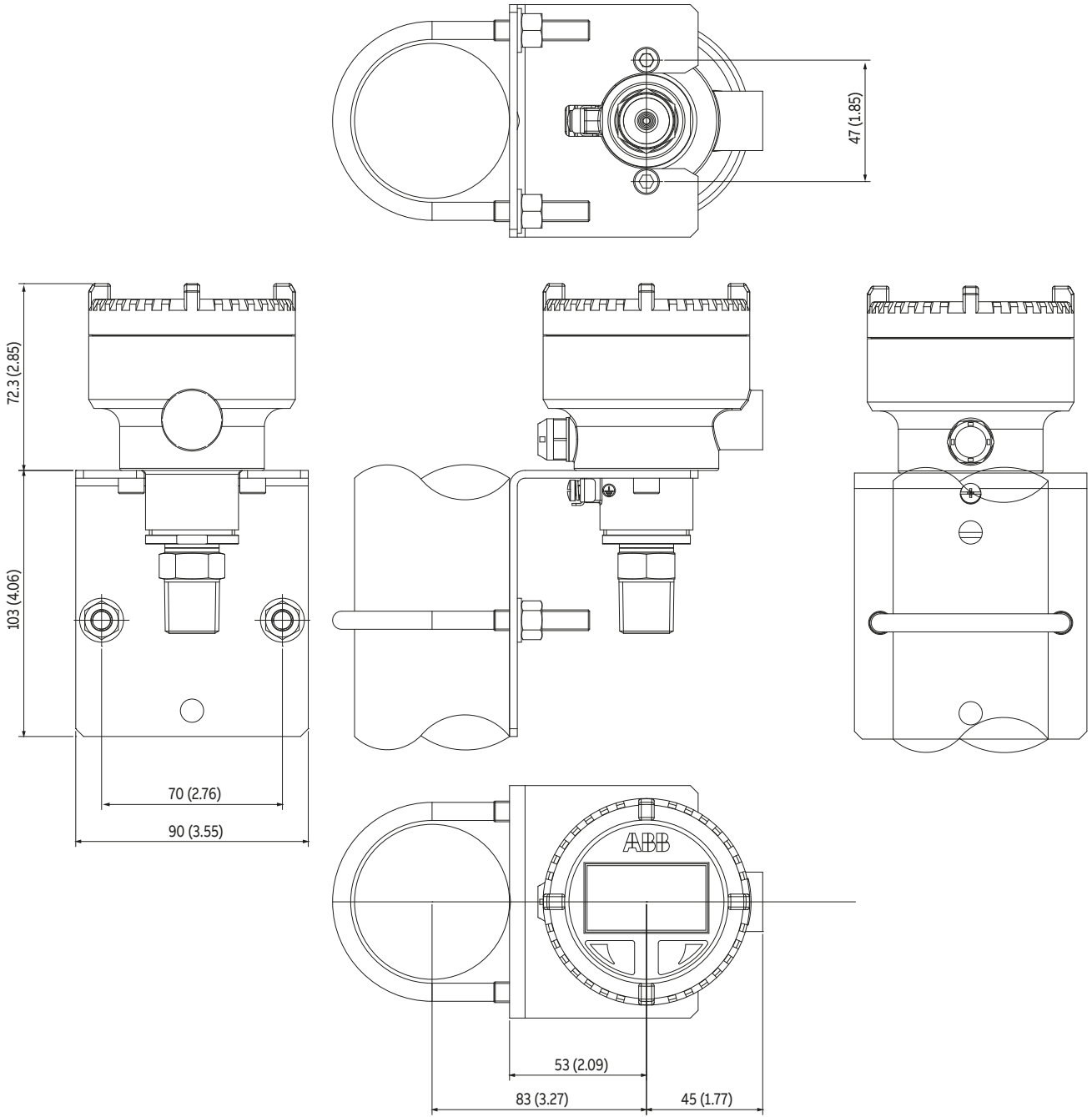

Figure 5 Pxs100 with 1/2 in NPT male / 1/4 in NPT female connection on bracket (Option code "B")

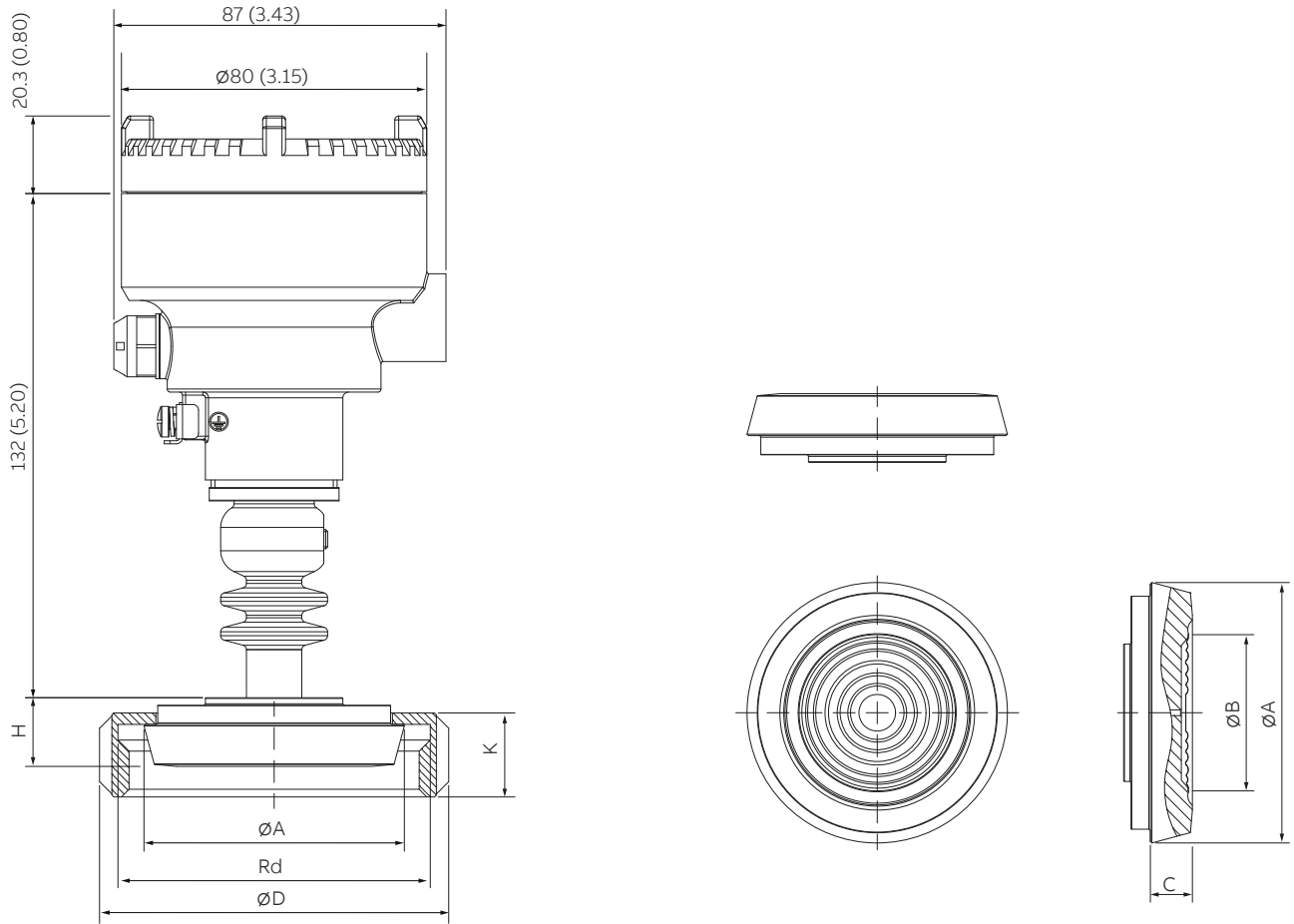

Figure 6 PXF100 with DIN11851

Size/ Rating	Option code	PN	A (dia)	B (dia)	C	D (dia)	Rd	H	K
DN40	F	40	55.8 (2.20)	38 (1.50)	10 (0.39)	78 (3.07)	65x1/6	15 (0.59)	21 (0.83)
DN50	G	25	68.2 (2.69)	41 (1.61)	11(0.43)	92 (3.62)	78x1/6	18 (0.71)	22 (0.87)

## ...Mounting dimensions

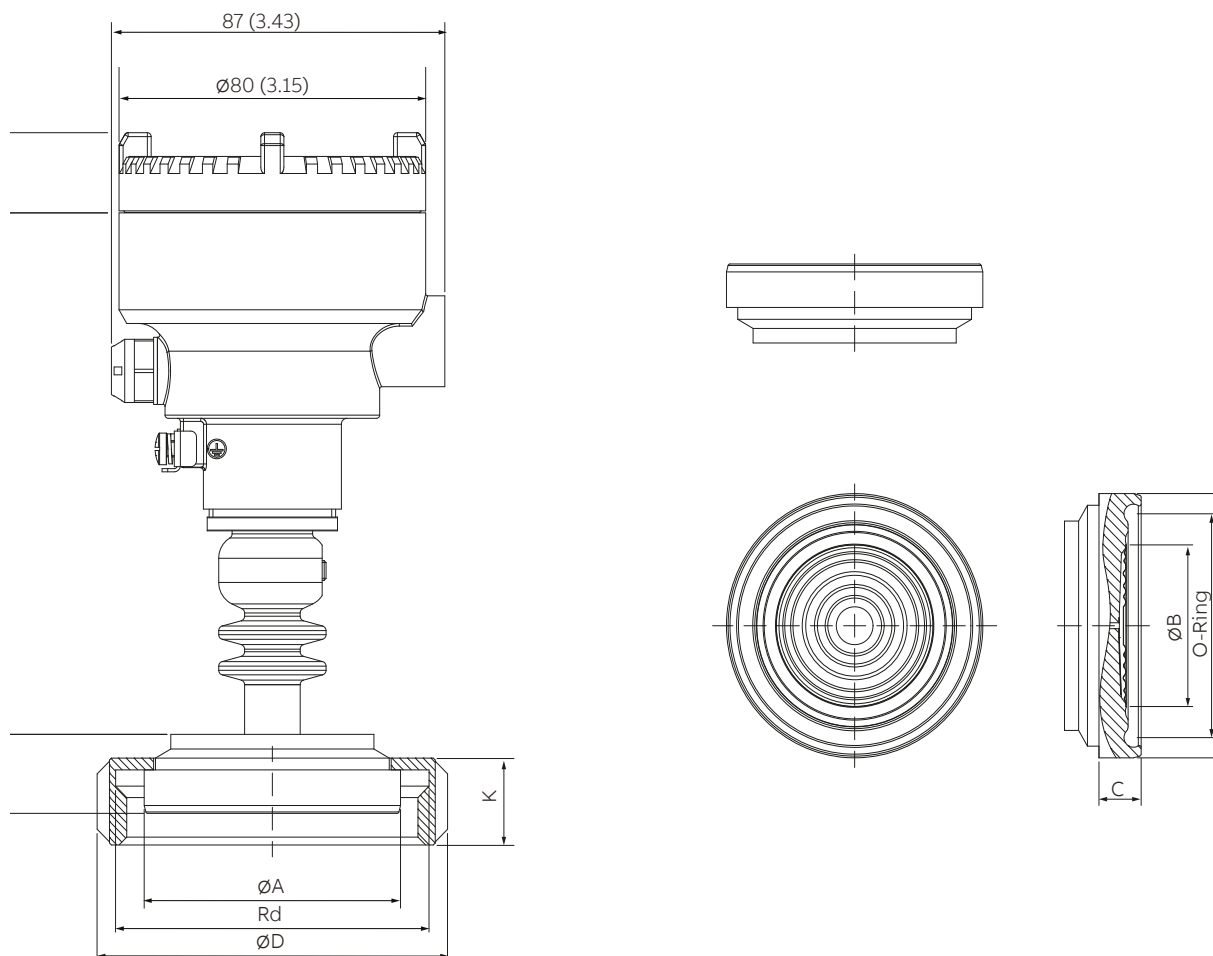

Figure 7 PXF100 with DIN11864 -1 FORM A

Size/ Rating	Option code	PN	A (dia)	B (dia)	C	D (dia)	Rd	H	K	O-RING
DN40	R	40	54.9 (2.16)	35 (1.38)	10 (0.39)	78 (3.07)	65x1/6	20 (0.79)	21 (0.83)	40x5
DN50	S	25	66.9 (2.63)	41 (1.61)	11(0.43)	92 (3.62)	78x1/6	20 (0.79)	22 (0.87)	52x5

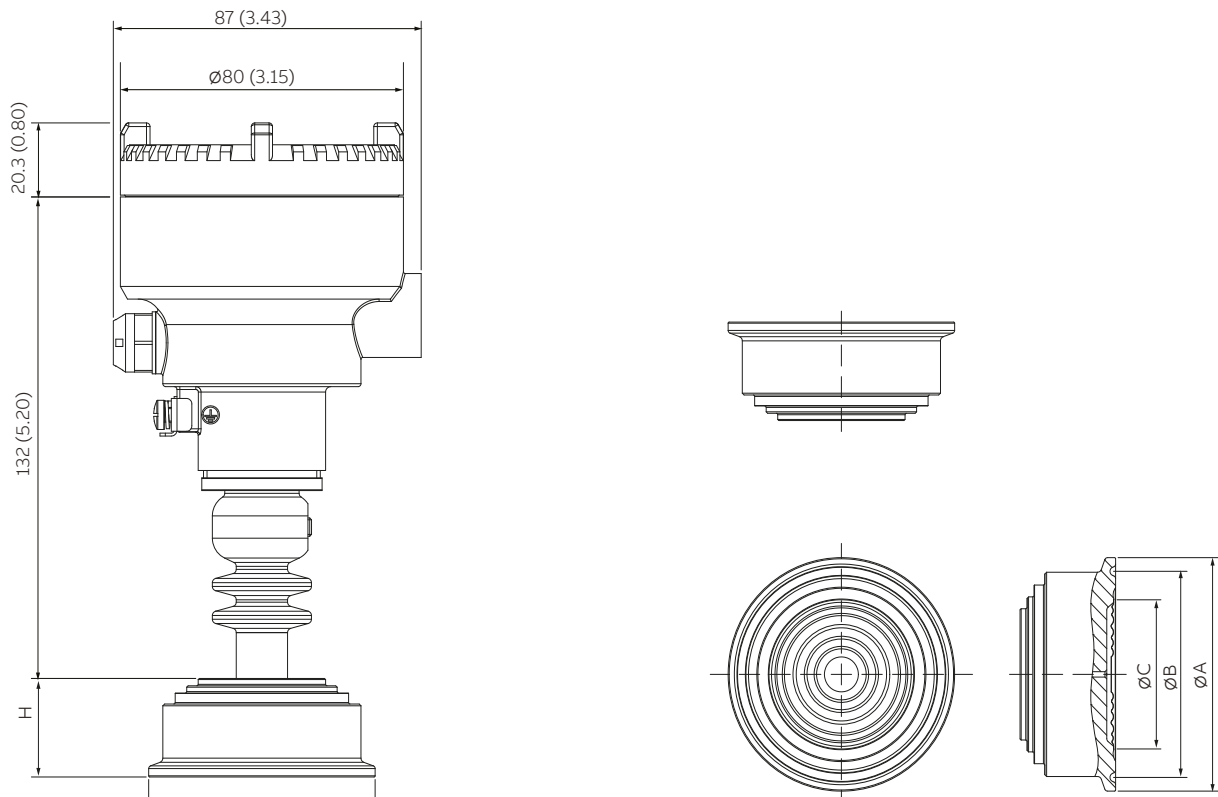

Figure 8 PXF100 with TRI CLAMP ISO 2852

Size/ Rating	Option code	PN	A (dia)	B (dia)	C (dia)	H
1 in. - DN25	T	40	50.5 (1.99)	43.5 (1.71)	22.5 (0.89)	21.5 (0.85)
1 1/2 in. - DN38	A	40	50.5 (1.99)	43.5 (1.71)	35 (1.38)	21.5 (0.85)
2 in. - DN51	B	38	64 (2.52)	56.5 (2.22)	41 (1.61)	27 (1.06)
3 in. - DN76.1	C	24	91 (3.58)	83.5 (3.29)	72 (2.83)	27 (1.06)
4 in. - DN101.6	D	17	119 (4.69)	110 (4.33)	72 (2.83)	27 (1.06)

...Mounting dimensions

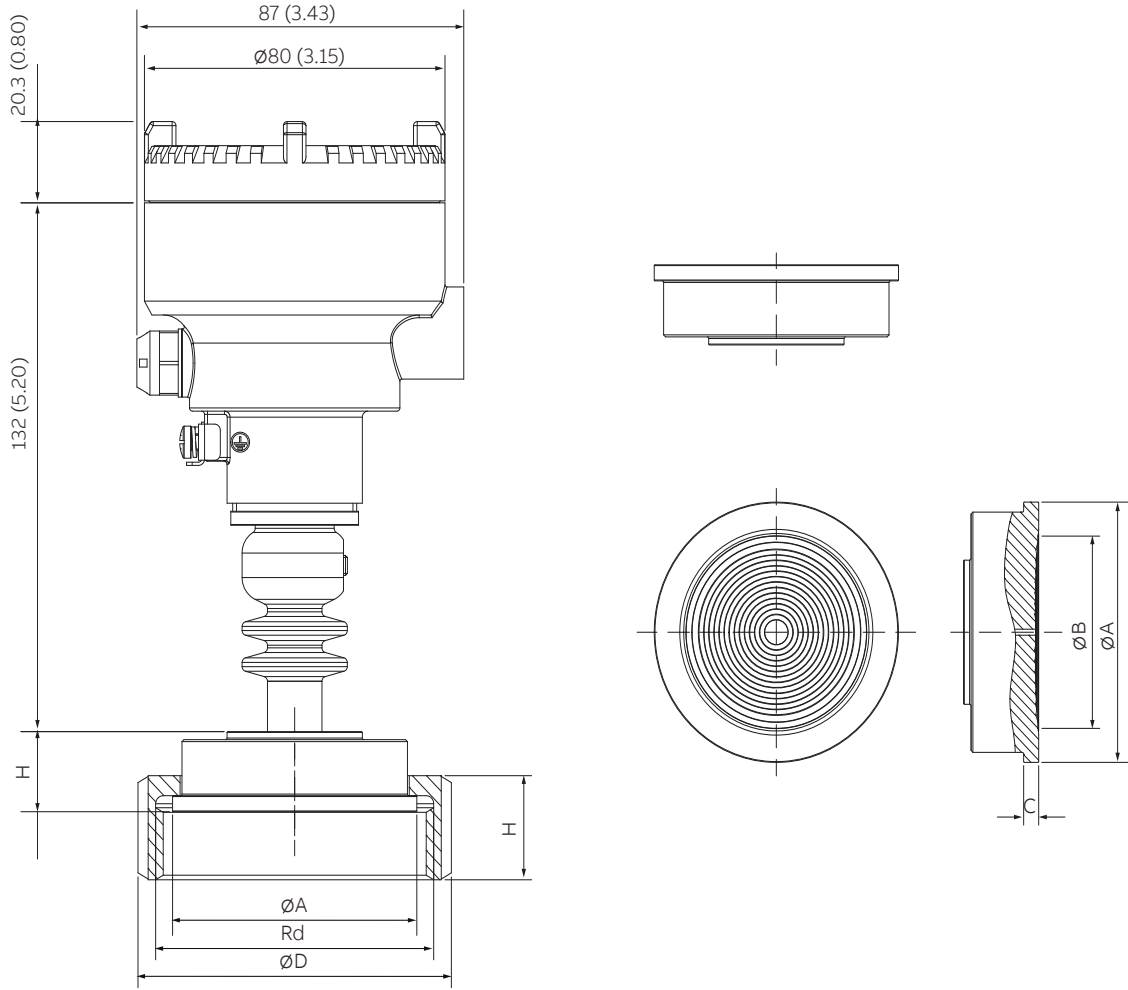

Figure 9 PXF100 with SMS SS1145

Size/ Rating	Option code	PN	A (dia)	B (dia)	C	D (dia)	Rd	H	K
SMS 38	H	40	55 (2.17)	35 (1.38)	4 (0.16)	74 (2.91)	60-6	20 (0.79)	25 (0.98)
SMS 51	L	40	65 (2.56)	48 (1.89)	4 (0.16)	84 (3.31)	70-6	20 (0.79)	26 (1.02)

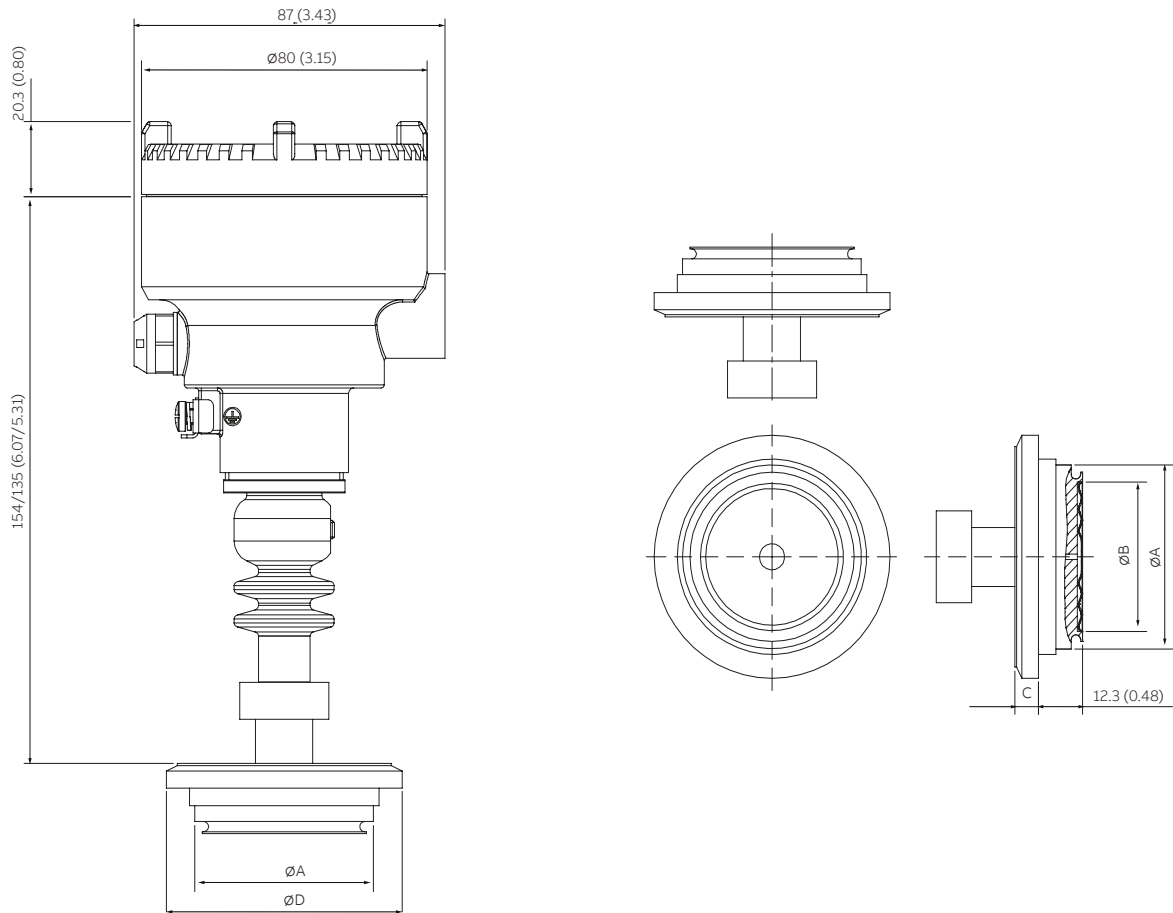

Figure 10 PXF100 with Varinline®

Size/ Rating	Option code	PN	A (dia)	B (dia)	C	D (dia)
F DN25 (1 in.)	M	25	50 (1.97)	40 (1.58)	17 (0.67)	66 (2.60)
N DN40 - DN150 (1 1/2 in. - 6 in)	N	25	68 (2.68)	60(2.68)	19 (0.75)	84 (3.31)

## ...Mounting dimensions

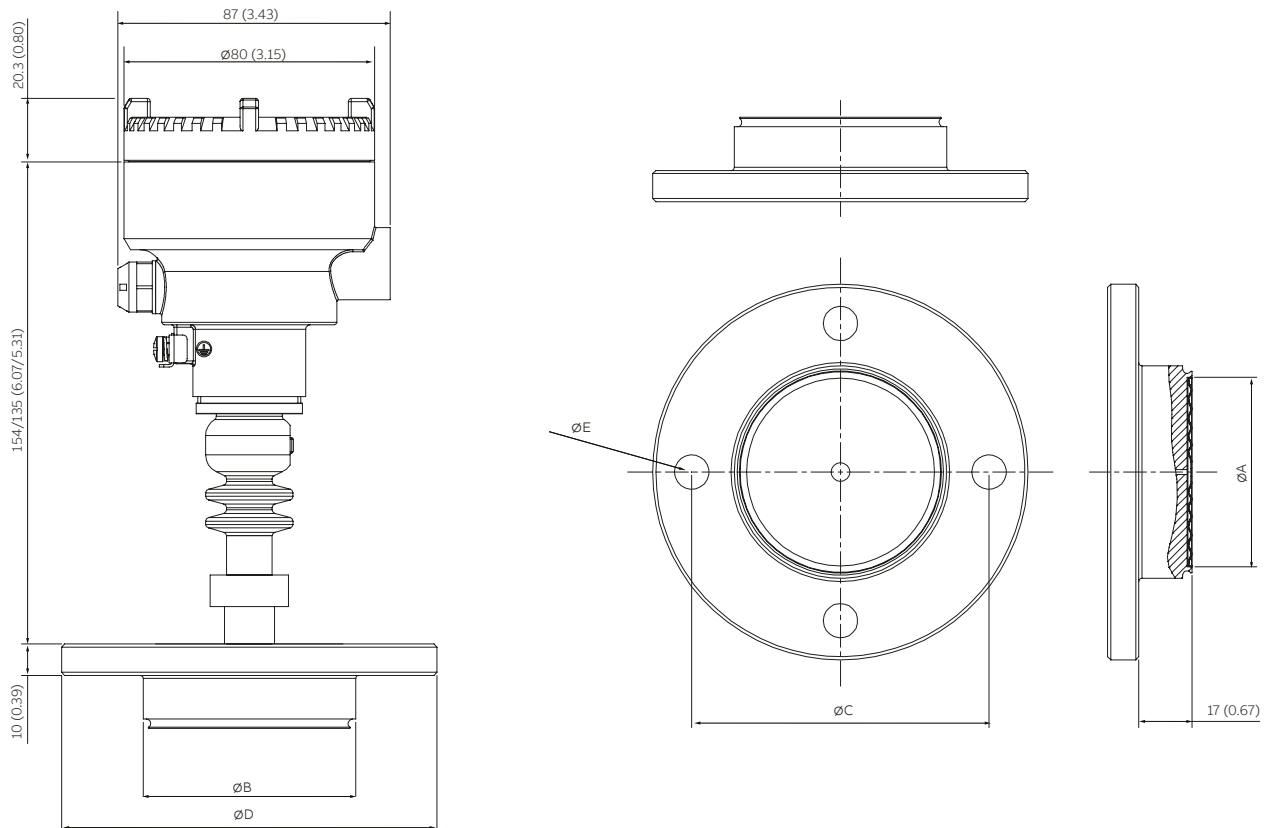

Figure 11 PXF100 with Neumo Biocontrol®

Size/ Rating	Option code	PN	A (dia)	B (dia)	C (dia)	D (dia)	4 x E (dia)
D50	P	16	40 (1.57)	50 (1.97)	70 (2.76)	90 (3.54)	9 (0.35)
D65	Q	16	59 (2.32)	68 (2.68)	95 (3.74)	120 (4.72)	11 (0.43)



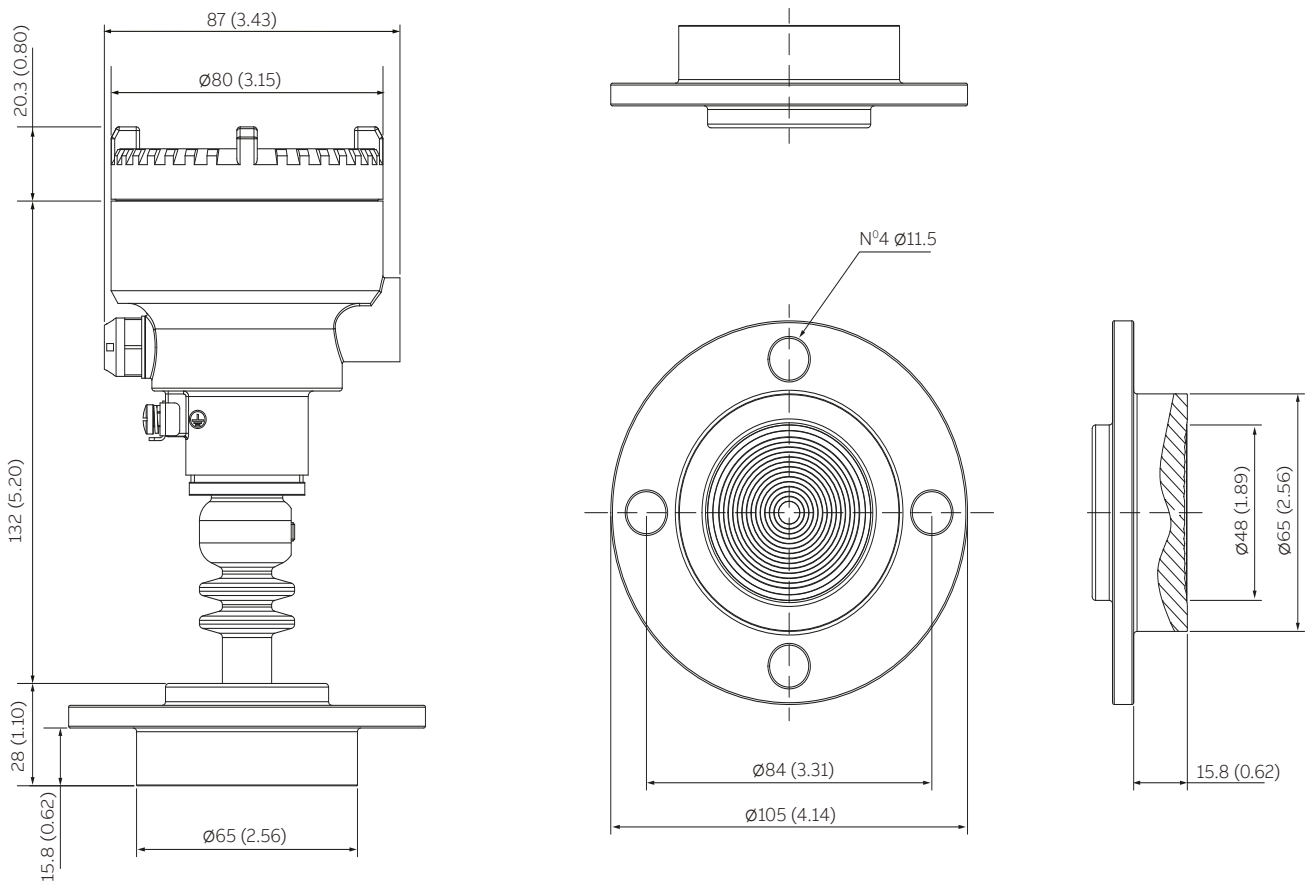

Figure 12 PXF100 with DRD (Option code "E")

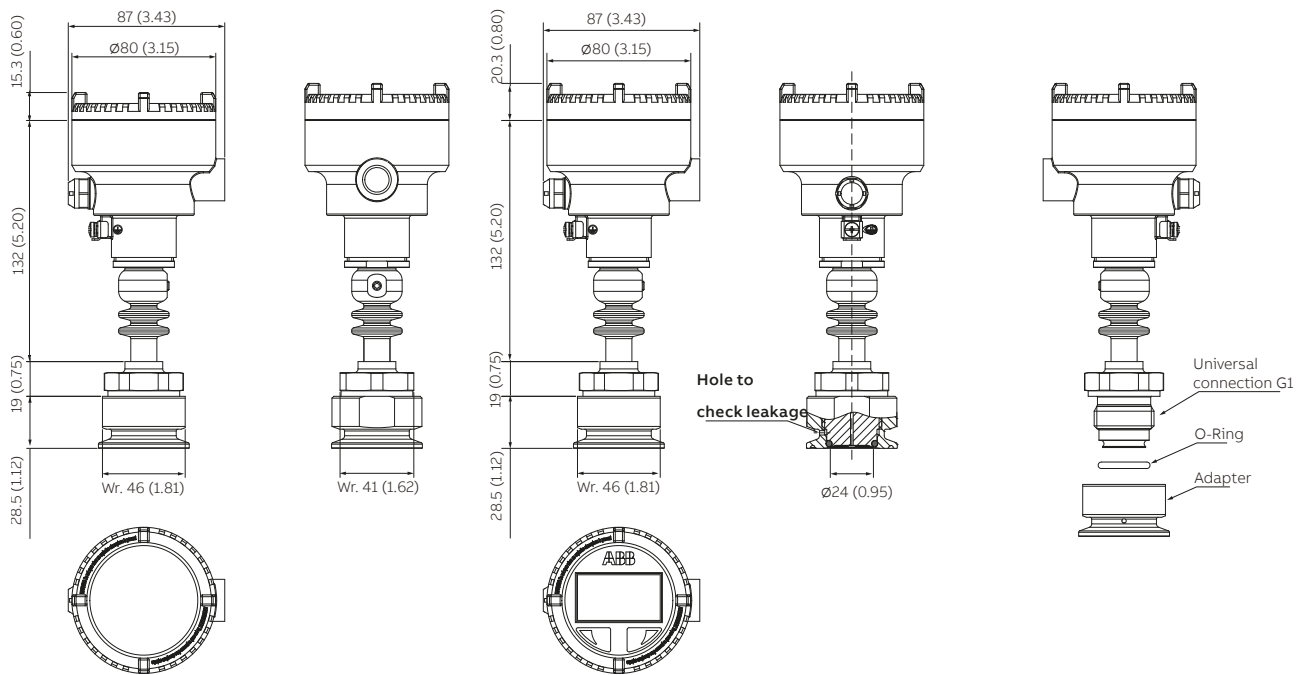

Figure 13 PXF100 with Universal connection and hygienic adapter (Option code "U")

...Mounting dimensions

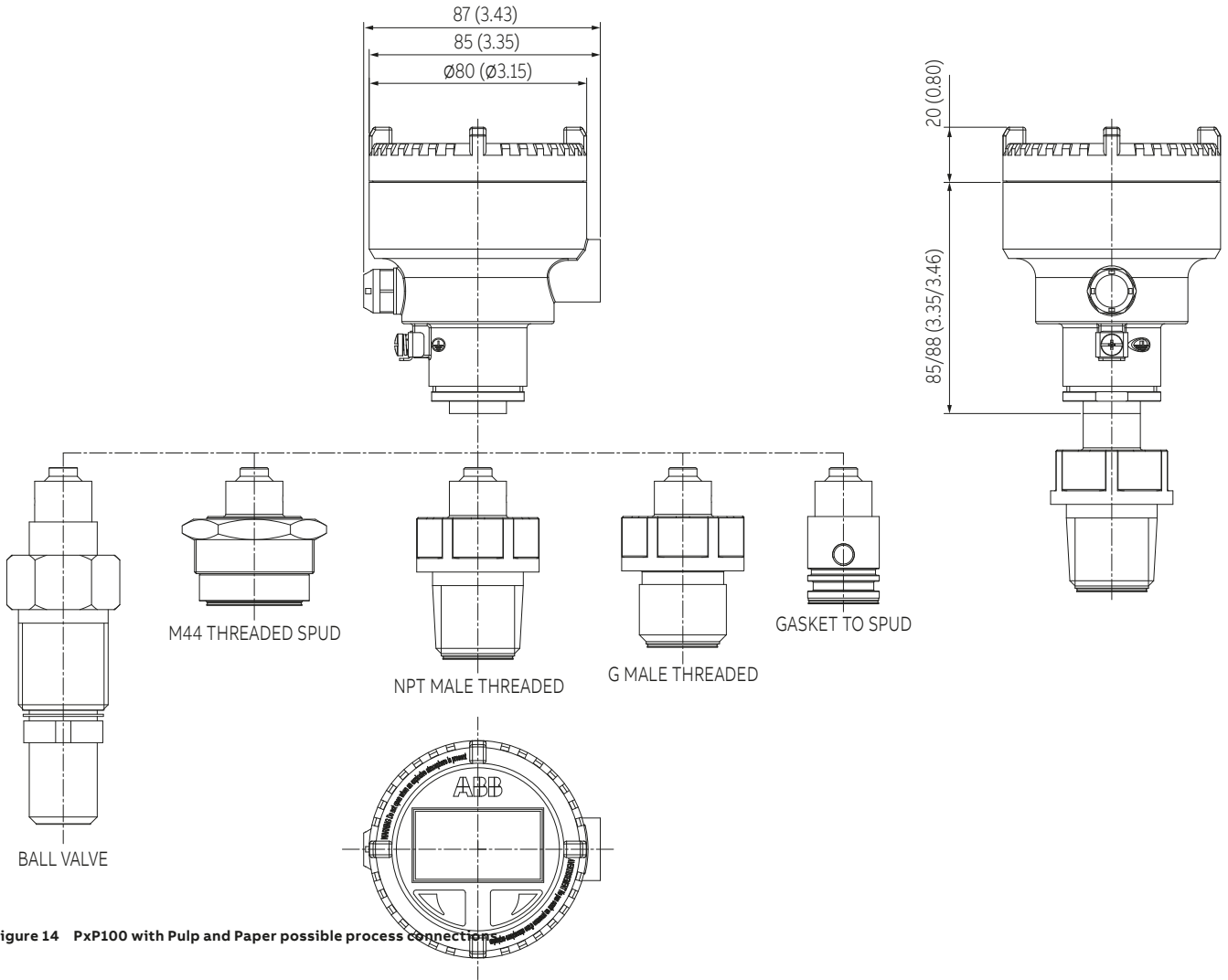

Figure 14 PXP100 with Pulp and Paper possible process connections

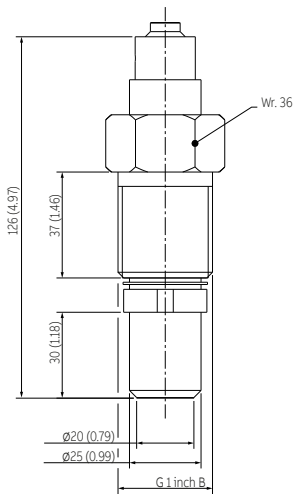

Figure 15 PXP100 with Ball Valve (Option code "E")

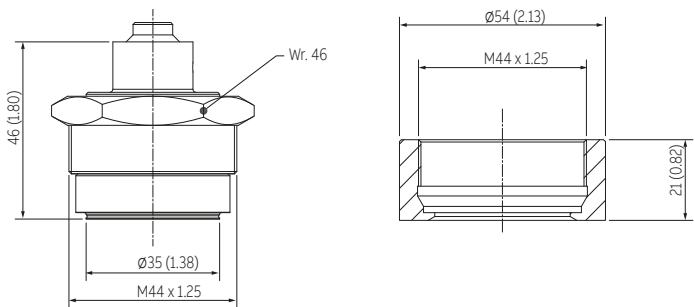

Figure 16 PXP100 with M44 Threaded Spud (Option code "G")

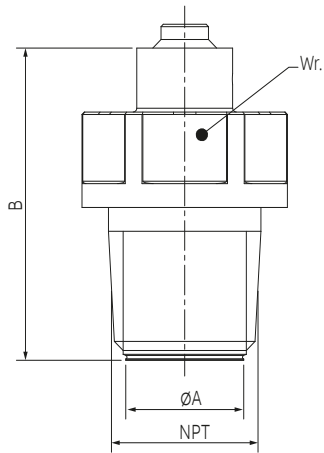

Figure 18 PXP100 with NPT male threaded

NPT	Option code	MWP (bar)	ØA	B	Wr.
1 in.	C	345	26 (1,02)	65 (2,56)	41
1 1/2 in.	D	345	39 (1,54)	66 (2,6)	55

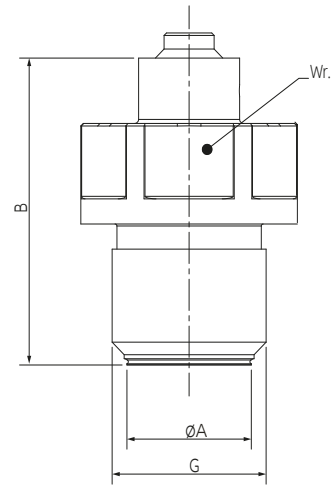

Figure 19 PXP100 with G male Threaded

G (ISO 228)	Option code	MWP (bar)	A (dia)	B	Wrench
G 1 in.	A	600	26 (1.02)	61(2.4)	41
G 1 1/2 in.	B	600	39 (1.54)	63 (2.48)	55

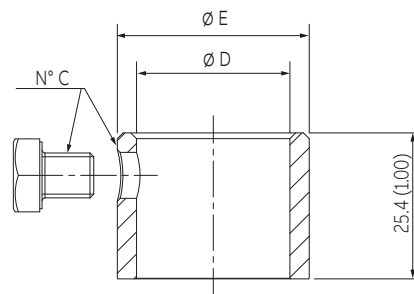
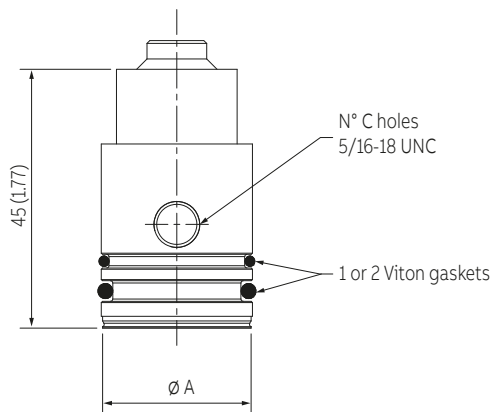

Figure 17 PXP100 with Gasket to Spud (Spud to be ordered separately)

Size/ Rating	Option code	MWP (Bar)	A (dia)	C	No. of Gaskets	1st O-ring	2nd O-ring	D (dia) Welding Spud	E (dia) Welding Spud
1 in.	F	30	26 (1.02)	1	2	20.24x2.62	23.52x1.78	70 (2.76)	90 (3.54)
1 1/2 in.	H	50	40 (1.57)	2	1	32.92x3.53	-	95 (3.74)	120 (4.72)

## ...Mounting dimensions

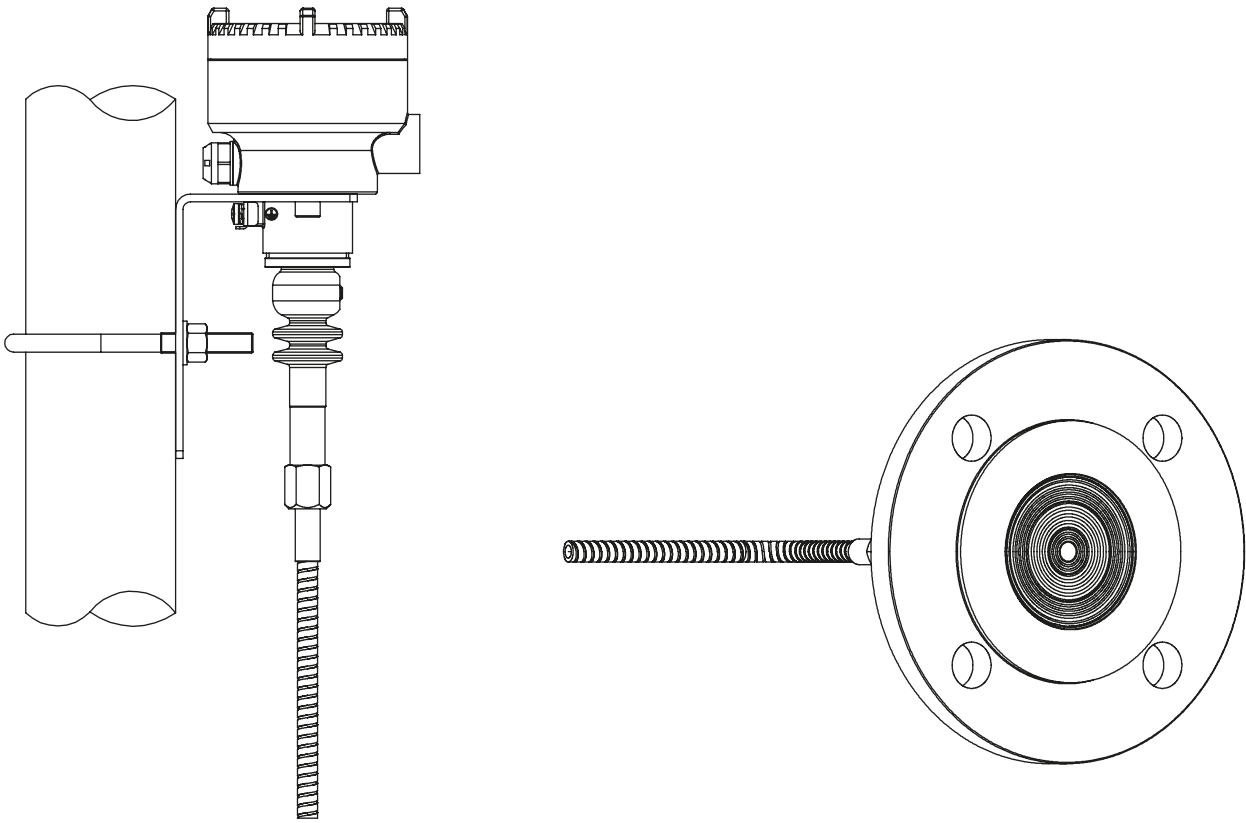

Figure 20 PxD100 with remote seal.  
(This is only a representative drawing. For detailed drawings of the remote seal please refer to the S26 datasheet)

## Electrical connections

### HART version

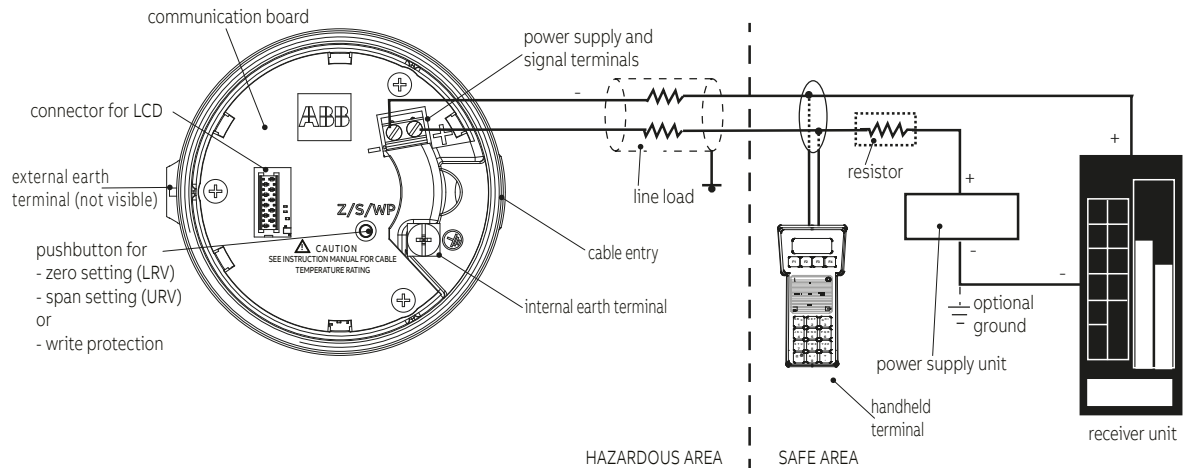

Figure 21 Connections

HART communication requires a minimum loop resistance of 250 ohm. If this is less than 250 ohm, additional resistance should be added.



**Additional ordering information model PGS100 Gauge Pressure Transmitters and PAS100 Absolute Pressure Transmitters**  
 Add one or more options code after the basic ordering information to select all required options.

	XX	XX	XXX	XX	XX	XX	XX	XX
<b>LCD Display (see FOOTNOTE)</b>								
Glass touch LCD display with 2-button keypad	D3							
Backlit glass touch LCD display with 2-button keypad	D4							
<b>Extended performances</b>								
± 0,075% extended Base accuracy		E7						
± 0.10 % extended base accuracy		E9						
<b>Hazardous area certifications (see relevant paragraph for complete detailed markings)</b>								
ATEX Ex ia and Ex ta/tb	(Note 4)		HAM					
CSA approvals (USA and Canada) IS (Gas and Dust)	(Note 4)		HCM					
IECEX Ex ia and Ex ta/tb	(Note 4)		HJM					
Combined ATEX, CSA approvals (USA and Canada) and IECEx (Gas and Dust)	(Note 4)		HMM					
NEPSI China (Ex ia and Ex iaD / Ex tD)			HMN					
INMETRO (Brazil) Ex ia and Ex ta/tb			HMB					
EAC Ex ia and Ex ta/tb			HME					
<b>Approvals</b>								
CSA ordinary location (USA and Canada)	(Note 4)		GO					
DM174 water approval	(Note 5)		GD					
WRAS water approval (Tmax = 85 °C for Process connection size code P and 100 °C for codes A, B, C)	(Note 5)		GW					
Combined water approvals	(Note 5)		GA					
<b>Physical application</b>								
Oxygen service cleaning, (only available with inert oil fill)	(Note 6)				P1			
Pmax =10 MPa for Galden; Tmax=60 °C/140 °F or max. working pressure								
<b>Accessories</b>								
External grounding terminal (fitted as standard if hazardous area certification code Hxx is selected)							AG	
Manifold assembly	(Note 7, 8)						AM	
<b>Mounting bracket</b>								
Universal for pipe or wall mounting / AISI 304 ss (1.4301)								BU
<b>Software application</b>								
Calibration to specified measuring span and/or tag number (and printed on plastic label)	(Note 9)							SC
Alarm setting to low current of 3.6 mA								SA
Digital access diagnostics (requires backlit LCD display code D4)								SD
Local configuration (Easy Set Up) for 4..20mA Version	(Note 10)							SE

NOTE - Refer to hazardous atmospheres paragraph for compliance of digital display

## ...Ordering Information

... Additional ordering information model PGS100 Gauge Pressure Transmitters and PAS100 Absolute Pressure Transmitters

	XX	XXX	XX
<b>Inspection/compliance certificates</b>			
Inspection certificate EN 10204–3.1 of calibration (5-point) (Note 11)	CF		
Inspection Certificate UNI EN 10204 3.1 (9 points calibration) (Note 12)	CN		
Inspection certificate EN 10204–3.1 of cleanliness stage	CC		
Inspection certificate EN 10204–3.1 of helium leakage test of the sensor module	CL		
Inspection certificate EN 10204–3.1 of the pressure test	CH		
Certificate of compliance with the order EN 10204–2.1 of instrument design	CD		
Inspection certificate EN 10204–3.1 of process wetted parts	CM		
Certificate of compliance with the order EN 10204–2.1 of pressure bearing and wetted parts	CW		
<b>Labels</b>			
Label and display visualization in imperial units (Pressure = inH2O/ psi at 68 °F; Temperature = deg. F)		LTU	
Supplemental wired–on stainless steel plate (4 lines, 32 characters each)		LEW	
Label and display visualization in Chinese		LTS	
<b>Manuals</b>			
German			M1
Italian (PENDING)			M2
Spanish (PENDING)			M3
French (PENDING)			M4
English			M5
Chinese (PENDING)			M6
Portuguese (PENDING)			MA
Russian (PENDING)			MB

- Note 1: Only available with Front bonded G 1/2 in process connection code P
- Note 2: For 10000 kPa/100 bar/1450 psi sensor code R, H-Shield is only available with front bonded G 1/2 in process connection code P
- Note 3: Not available with 40 kPa/400 mbar/160 inH2O/300 mmHg sensor code F
- Note 4: Hazardous area certification and CSA ordinary location options are mutually exclusive
- Note 5: Available only with Diaphragm material code A
- Note 6: Not available with DIN EN 837-1 G 1/2 B process connection code C
- Note 7: Not available with any Ex certificates.
- Note 8: Not available with Physical application code P1
- Note 9: Option code SC has to be ordered if 0 to URL calibration record is required
- Note 10: Available only with Output code A
- Note 11: Option code CF provides an inspection certificate of calibration 0 to URL  
Option code SC should be also selected if the inspection certificate is required for calibration different from 0 to URL
- Note 12: Mutually exclusive with Inspection certificate code CF

### Standard delivery items (can be differently specified by additional ordering code)

- For general purpose applications (no Ex application certification)
- EPDM O-ring for G 1/2 front bonded process connection, flush diaphragm
- No display, no mounting bracket
- Short-form leaflet instruction and labels in English
- Configuration with kPa and deg. C units
- No test, inspection or material traceability certificates

### IMPORTANT REMARK FOR ALL MODELS

THE SELECTION OF SUITABLE WETTED PARTS AND FILLING FLUID FOR COMPATIBILITY WITH THE PROCESS MEDIA IS A CUSTOMER’S RESPONSIBILITY, IF NOT OTHERWISE NOTIFIED BEFORE MANUFACTURING.



## Ordering Information

Basic ordering information PGF100 Gauge Pressure Transmitters and PAF100 Absolute Pressure Transmitters

Select one character or set of characters from each category and specify complete catalog number.

Refer to additional ordering information and specify one or more codes for each transmitter if additional options are required.

<b>Base model – 1st to 6th characters</b>			X	X	X	X	X
Gauge pressure transmitter, compact class, base accuracy 0.1 %			PGF100				
Absolute pressure transmitter, compact class, base accuracy 0.1 %			PAF100				
<b>Sensor range – 7th character</b>							
6 kPa	60 mbar	24 inH2O	C				
40 kPa	400 mbar	160 inH2O	F				
250 kPa	2500 mbar	36.26 psi	L				
1000 kPa	10 bar	145 psi	D				
4000 kPa	40 bar	580 psi	K				
10000 kPa	100 bar	1450 psi	(Note 1) R				
<b>Maximum working pressure – 8th and 9th characters</b>							
Standard by design according to sensor range				S9			
<b>Diaphragm material – 10th character</b>							
AISI 316 L ss					A		
Hastelloy C-276			(Note 2)		H		
Diaflex antiabrasion coating on AISI 316 L ss			(Note 2)		F		
Diaflex antiabrasion coating on Hastelloy C-276			(Note 2)		C		
<b>Fill fluid – 11th character</b>							
Silicone oil						1	
Inert oil						2	
Mineral white oil (FDA)						3	
Vegetal white oil (FDA)						5	
<b>Process connection material – 12th character</b>							
AISI 316 L ss							A

## ...Ordering Information

...Basic ordering information PGF100 Gauge Pressure Transmitters and PAF100 Absolute Pressure Transmitters

	X	X	X	X
<b>Process connection size – 13th character</b>				
Front bonded G 1 in hygienic (adapter-compatible) (Note 3, 5, 8, 9, 21)	U			
Tri-Clamp ISO2852 DN38 (1 1/2 in), DIN 32676 DN40 (Note 4, 7, 9, 21)	A			
Tri-Clamp ISO2852 DN 25 (1"), DIN 32676 DN 25 (Note 4, 7, 9, 21)	T			
Tri-Clamp ISO2852 DN 51 (2 in), DIN 32676 DN 50 (Note 4, 7, 9, 21)	B			
Tri-Clamp ISO2852 DN 76.1 (3 in), DIN 32676 DN65 (Note 7, 9)	C			
Tri-Clamp ISO2852 DN 101.6 (4 in) DIN 32676 DN 100 (Note 7, 9)	D			
DRD 65mm (DN 50) (Note 7, 9, 21)	E			
Dairy 11851 DN40 PN40 (Note 6, 7, 9, 21)	F			
Dairy 11851 DN50 PN25 (Note 6, 7, 9, 21)	G			
SMS 1 1/2 in PN40 (dia 35) (Note 7, 17, 21)	H			
SMS 2 in PN40 (dia 45) (Note 7, 17, 21)	L			
Varinline® F DN25 (Note 7, 9, 19)	M			
Varinline® N DN40 (Note 7, 9, 20)	N			
Neumo Biocontrol® D50 (Note 7, 9, 18)	P			
Neumo Biocontrol® D65 (Note 7, 9, 18)	Q			
Dairy DIN 11864-1 typeA DN40 PN16 (Note 7, 9, 21)	R			
Dairy DIN 11864-1 typeA DN50 PN16 (Note 7, 9, 21)	S			
<b>Bolts and gaskets – 14th character</b>				
None		Y		
<b>Housing material / Electrical connection – 15th character</b>				
AISI 316 L ss / M16 x 1.5 thread				U
AISI 316 L ss / M20 x 1.5 female thread (through adapter - supplied loose)				T
AISI 316 L ss / 1/2 in -14 NPT female thread (through adapter - supplied loose)				S
<b>Protocol/Output – 16th characters</b>				
4 – 20 mA analog signal only (only zero/span settings are available)				A
HART digital communication and 4 – 20 mA (Easy setup menu is available for configuration settings)				H

**Additional ordering information model PGF100 Gauge Pressure Transmitters and PAF100 Absolute Pressure Transmitters**  
 Add one or more options code after the basic ordering information to select all required options.

	XX	XX	XXX	XX	XX	XX	XX
<b>LCD Display (see FOOTNOTE)</b>							
Glass touch LCD display with 2-button keypad	D3						
Backlit glass touch LCD display with 2-button keypad	D4						
<b>Extended performances</b>							
± 0.075 % extended base accuracy		E7					
<b>Hazardous area certifications (see relevant paragraph for complete detailed markings)</b>							
ATEX Ex ia and Ex ta/tb	(Note 10)		HAM				
CSA approvals (USA and Canada) IS (Gas and Dust)	(Note 10)		HCM				
IECEX Ex ia and Ex ta/tb	(Note 10)		HJM				
Combined ATEX, CSA approvals (USA and Canada) and IECEX (Gas and Dust)	(Note 10)		HMM				
<b>Approvals</b>							
CSA ordinary location (USA and Canada)	(Note 10)			GO			
Combined 3A & EHEDG approvals	(Note 9, 11)			GF			
<b>Physical application</b>							
Vacuum-proof design					P8		
<b>Accessories</b>							
External grounding terminal (fitted as standard if hazardous area certification code Hxx is selected)							AG
<b>Software application</b>							
Calibration to specified measuring span and/or tag number (and printed on plastic label)	(Note 12)						SC
Alarm setting to low current of 3.6 mA							SA
Digital access diagnostics (requires backlit LCD display code D4)							SD
Local configuration (Easy Set Up) for 4..20mA Version	(Note 13)						SE

NOTE - Refer to hazardous atmospheres paragraph for compliance of digital display

NOTE - Vacuum proof design (Option P8) is suggested primarily when rapid and large temperature changes occur in process fully or partially working in vacuum conditions (i.e. sanitization, etc). The design, which uses metallic components specifically treated, could also be beneficial in vacuum processes where the process temperature is relatively high (above 100° C / 212 °F)

## ...Ordering Information

... Additional ordering information model PGF100 Gauge Pressure Transmitters and PAF100 Absolute Pressure Transmitters

	XX	XXX	XX	XX
<b>Inspection/compliance certificates</b>				
Inspection certificate EN 10204–3.1 of calibration (5-point) (Note 14)	CF			
Inspection Certificate UNI EN 10204 3.1 (9 points calibration) (PENDING) (Note 15)	CN			
Inspection certificate EN 10204–3.1 of cleanliness stage	CC			
Inspection certificate EN 10204–3.1 of helium leakage test of the sensor module	CL			
Inspection certificate EN 10204–3.1 of the pressure test	CH			
Certificate of compliance with the order EN 10204–2.1 of instrument design	CD			
Inspection certificate EN 10204–3.1 of process wetted parts	CM			
Certificate of compliance with the order EN 10204–2.1 of pressure bearing and wetted parts	CW			
<b>Labels</b>				
Label and display visualization in imperial units (Pressure = inH2O/ psi at 68 °F; Temperature = deg. F)		LTU		
Supplemental wired-on stainless steel plate (4 lines, 32 characters each)		LEW		
Label and display visualization in Chinese		LTS		
<b>Manuals</b>				
German			M1	
Italian (PENDING)			M2	
Spanish (PENDING)			M3	
French (PENDING)			M4	
English			M5	
Chinese (PENDING)			M6	
Portuguese (PENDING)			MA	
Russian (PENDING)			MB	
<b>Other Accessories</b>				
Gasket for Front bonded G 1 - EPDM for F&B (FDA, EC 1935/2004) (Note 16)				RF
Gasket for Front bonded G 1 - FKM for F&B (FDA, EC 1935/2004) (Note 16)				RK
Gasket for Front bonded G 1 - HNBR for F&B (FDA, EC 1935/2004) (Note 16)				RN

Note 1: Not available with Diaphragm material F,C & Process connection size code U

Note 2: Only available with process connection code U

Note 3: All ABB adapters used with the Front Bonded G1 in hygienic connection have a leak detect port of 2.4 mm, which must be positioned at the lowest point for the installation.

Note 4: Pipe couplings ISO 2852, DIN 32676, BS 4825 Part 3 are according to EHEDG only in combination with Tri-Clamps seals Combifit International B.V., The Netherlands.

Note 5: Not available with sensor range R

Note 6: Pipe couplings DIN 11851 are according to EHEDG, 3A only in combination with ASEPTO-STAR k-flex upgrade gaskets Kieselmann GmbH, Germany.

Note 7: Not available with Diaphragm material codes H,F and C

Note 8: Not available with Diaphragm material codes F,C

Note 9: 3A approved. 3A approval works for 1 in. G universal connection only in combination with relevant gaskets (digit RF,RK,RN) and accessories (ordering code PZH)

Note 10: Hazardous area certification and CSA ordinary location options are mutually exclusive

Note 11: Not applicable with process connections digits C,D,E,H,L,P,Q,U

Note 12: Option code SC has to be ordered if 0 to URL calibration record is required

Note 13: Available only with Output code A

Note 14: Option code CF provides an inspection certificate of calibration 0 to URL

Option code SC should be also selected if the inspection certificate is required for calibration different from 0 to URL

Note 15: Mutually exclusive with Inspection certificate code CF

Note 16: Only with Process connection code U

Note 17: Gauge couplings SMS SS1145 are according to 3A (CIP) only if special conditions for use are followed (please see the Operating manual for more details)

Note 18: Pipe couplings Neumo Biocontrol® are according to 3A (CIP) only if special conditions for use are followed (please see the Operating manual for more details).

Note 19: Varinline® type F process connection is according to EHEDG only on the Varinline® tank flange type T and P with EPDM o-ring. Varinline® GEA Tuchenhausen GmbH, Germany.

Note 20: Varinline® type N process connection is according to EHEDG only on the Varinline® tank flange type T and P and Varinline® System housing with EPDM o-ring. Varinline® GEA Tuchenhausen GmbH, Germany.

Note 21: Not available with sensor codes C & F



## ...Ordering information

### Additional ordering information model PGP100 Gauge Pressure Transmitters and PAP100 Absolute Pressure Transmitters

Add one or more options code after the basic ordering information to select all required options.

	XX	XX	XXX	XX	XX	XX	XX	XX
<b>LCD Display (see FOOTNOTE)</b>								
Glass touch LCD display with 2-button keypad	D3							
Backlit glass touch LCD display with 2-button keypad	D4							
<b>Extended performances</b>								
± 0.075 % extended base accuracy		E7						
<b>Hazardous area certifications (see relevant paragraph for complete detailed markings)</b>								
ATEX Ex ia and Ex ta/tb (PENDING)	(Note 3)		HAM					
CSA approvals (USA and Canada) IS (Gas and Dust) (PENDING)	(Note 3)		HCM					
IECEX Ex ia and Ex ta/tb (PENDING)	(Note 3)		HJM					
Combined ATEX, CSA approvals (USA and Canada) and IECEX (Gas and Dust) (PENDING)	(Note 3)		HMM					
<b>Approvals</b>								
CSA ordinary location (USA and Canada) (PENDING)	(Note 3)			GO				
<b>Accessories</b>								
External grounding terminal (fitted as standard if hazardous area certification code Hxx is selected)						AG		
<b>Mounting bracket</b>								
Universal for pipe or wall mounting / AISI 304 ss (1.4301)							BU	
<b>OUTPUT CONFIGURATION</b>								
SIL2 (PENDING)	(Note 4)						NL	
<b>Software application</b>								
Calibration to specified measuring span and/or tag number (and printed on plastic label)	(Note 5)							SC
Alarm setting to low current of 3.6 mA								SA
Digital access diagnostics (requires backlit LCD display code D4)								SD

NOTE - Refer to hazardous atmospheres paragraph for compliance of digital display

	XX	XXX	XX
<b>Inspection/compliance certificates</b>			
Inspection certificate EN 10204–3.1 of calibration (5-point) (Note 6)	CF		
Inspection certificate EN 10204–3.1 of cleanliness stage	CC		
Inspection certificate EN 10204–3.1 of helium leakage test of the sensor module	CL		
Inspection certificate EN 10204–3.1 of the pressure test	CH		
Certificate of compliance with the order EN 10204–2.1 of instrument design	CD		
Inspection certificate EN 10204–3.1 of process wetted parts	CM		
Certificate of compliance with the order EN 10204–2.1 of pressure bearing and wetted parts	CW		
Inspection Certificate UNI EN 10204 3.1 (9 points calibration) (PENDING) (Note 7)	CN		
<b>Labels</b>			
Label and display visualization in imperial units (Pressure = inH2O/ psi at 68 °F; Temperature = deg. F)		LTU	
Supplemental wired–on stainless steel plate (4 lines, 32 characters each)		LEW	
Label and display visualization in Chinese		LTS	
<b>Manuals</b>			
German			M1
Italian (PENDING)			M2
Spanish (PENDING)			M3
French (PENDING)			M4
English			M5
Chinese (PENDING)			M6

Note 1: Available with diaphragm digit code A, F, D

Note 2: Available with diaphragm digit code H, C, D

Note 3: Hazardous area certification and CSA ordinary location options are mutually exclusive

Note 4: Available only with Display D3, D4

Note 5: Option code SC has to be ordered if 0 to URL calibration record is required

Note 6: Option code CF provides an inspection certificate of calibration 0 to URL

Option code SC should be also selected if the inspection certificate is required for calibration different from 0 to URL

Note 7: Not available with CF

**Standard delivery items (can be differently specified by additional ordering code)**

- For general purpose applications (no Ex application certification)
- No display, no mounting bracket
- Short-form leaflet instruction and labels in English
- Configuration with kPa and deg. C units
- No test, inspection or material traceability certificates

**IMPORTANT REMARK FOR ALL MODELS**

THE SELECTION OF SUITABLE WETTED PARTS AND FILLING FLUID FOR COMPATIBILITY WITH THE PROCESS MEDIA IS A CUSTOMER’S RESPONSIBILITY, IF NOT OTHERWISE NOTIFIED BEFORE MANUFACTURING.

## Ordering Information

Basic ordering information PGD100 Gauge Pressure Transmitters and PAD100 Absolute Pressure Transmitters

Select one character or set of characters from each category and specify complete catalog number.

Refer to additional ordering information and specify one or more codes for each transmitter if additional options are required.

<b>Base model – 1st to 6th characters</b>			X	X	X	X	X	X	X	X	X
Gauge pressure transmitter, compact class, base accuracy 0.25 %*			PGD100								
Absolute pressure transmitter, compact class, base accuracy 0.25 %*			PAD100								
<b>Sensor range – 7th character</b>											
6 kPa	60 mbar	24 inH2O	C								
40 kPa	400 mbar	160 inH2O	F								
250 kPa	2500 mbar	36.26 psi	L								
1000 kPa	10 bar	145 psi	D								
4000 kPa	40 bar	580 psi	K								
10000 kPa	100 bar	1450 psi	R								
<b>Maximum working pressure – 8th and 9th characters</b>											
Standard by design according to sensor range			S9								
<b>Diaphragm material (of Transducer)– 10th character</b>											
AISI 316 L ss			A								
<b>Fill fluid (of Transducer)– 11th character</b>											
Silicone oil			1								
<b>Process connection material – 12th character</b>											
Remote or direct mount seal * (one seal to be quoted separately)			R								
<b>Process connection size – 13th character</b>											
Remote or direct mount seal* (one seal to be quoted separately)			R								
<b>Bolts and gaskets – 14th character</b>											
None			Y								
<b>Housing material / Electrical connection – 15th character</b>											
AISI 316 L ss / M16 x 1.5 thread			U								
AISI 316 L ss / M20 x 1.5 female thread (through adapter - supplied loose)			T								
AISI 316 L ss / 1/2 in -14 NPT female thread (through adapter - supplied loose)			S								
<b>Protocol/Output – 16th characters</b>											
4 – 20 mA analog signal only (only zero/span settings are available)			A								
HART digital communication and 4 – 20 mA (Easy setup menu is available for configuration settings)			H								

(\*)Refer to [OI/DS-S26](#) for seal options



**Additional ordering information model PGD100 Gauge Pressure Transmitters and PAD100 Absolute Pressure Transmitters**  
 Add one or more options code after the basic ordering information to select all required options.

	XX	XX	XXX	XX	XX	XX	XX
<b>LCD Display (see FOOTNOTE)</b>							
Glass touch LCD display with 2-button keypad	D3						
Backlit glass touch LCD display with 2-button keypad	D4						
<b>Extended performances*</b>							
± 0.075 % extended base accuracy		E7					
± 0.1 % extended base accuracy		E9					
<b>Hazardous area certifications (see relevant paragraph for complete detailed markings)</b>							
ATEX Ex ia and Ex ta/tb	(Note 1)	HAM					
CSA approvals (USA and Canada) IS (Gas and Dust)	(Note 1)	HCM					
IECEX Ex ia and Ex ta/tb	(Note 1)	HJM					
Combined ATEX, CSA approvals (USA and Canada) and IECEx (Gas and Dust)	(Note 1)	HMM					
<b>Approvals</b>							
CSA ordinary location (USA and Canada)	(Note 1)		GO				
<b>Accessories</b>							
External grounding terminal (fitted as standard if hazardous area certification code Hxx is selected)					AG		
<b>Mounting bracket</b>							
Universal for pipe or wall mounting / AISI 304 ss (1.4301)	(Note 2)					BU	
<b>Software application</b>							
Calibration to specified measuring span and/or tag number (and printed on plastic label)	(Note 3)						SC
Alarm setting to low current of 3.6 mA							SA
Digital access diagnostics (requires backlit LCD display code D4)							SD
Local configuration (Easy Set Up) for 4..20mA Version	(Note 4)						SE

NOTE - Refer to hazardous atmospheres paragraph for compliance of digital display  
 (\*) Total performance of PxD shall be calculated considering also the other factors stated in the S26 datasheet/ manual

## ...Ordering Information

...Additional ordering information model PGD100 Gauge Pressure Transmitters and PAD100 Absolute Pressure Transmitters

	XX	XXX	XX
<b>Inspection/compliance certificates</b>			
Inspection certificate EN 10204–3.1 of calibration (5-point) (Note 5)	CF		
Inspection Certificate UNI EN 10204 3.1 (9 points calibration) (PENDING) (Note 6)	CN		
Inspection certificate EN 10204–3.1 of cleanliness stage	CC		
Inspection certificate EN 10204–3.1 of helium leakage test of the sensor module	CL		
Inspection certificate EN 10204–3.1 of the pressure test	CH		
Certificate of compliance with the order EN 10204–2.1 of instrument design	CD		
Inspection certificate EN 10204–3.1 of process wetted parts	CM		
Certificate of compliance with the order EN 10204–2.1 of pressure bearing and wetted parts	CW		
<b>Labels</b>			
Label and display visualization in imperial units (Pressure = inH2O/ psi at 68 °F; Temperature = deg. F)		LTU	
Supplemental wired-on stainless steel plate (4 lines, 32 characters each)		LEW	
Label and display visualization in Chinese		LTS	
<b>Manuals</b>			
German			M1
Italian (PENDING)			M2
Spanish (PENDING)			M3
French (PENDING)			M4
English			M5
Chinese (PENDING)			M6
Portuguese (PENDING)			MA
Russian (PENDING)			MB

Note 1: Hazardous area certification and CSA ordinary location options are mutually exclusive

Note 2: Available only when coupled with S26 remote mount

Note 3: Option code SC has to be ordered if 0 to URL calibration record is required

Note 4: Available only with Output code A

Note 5: Option code CF provides an inspection certificate of calibration 0 to URL

Option code SC should be also selected if the inspection certificate is required for calibration different from 0 to URL

Note 6: Mutually exclusive with Inspection certificate code CF

### Trademarks

Neumo Biocontrol® is a registered trademark of NEUMO-Ehrenberg Group

VARINLINE® is a registered trademark of GEA Tuchenhausen GmbH



---

## **ABB Measurement & Analytics**

For your local ABB contact, visit:  
[www.abb.com/contacts](http://www.abb.com/contacts)

For more product information, visit:  
[www.abb.com/pressure](http://www.abb.com/pressure)

We reserve the right to make technical changes or modify the contents of this document without prior notice. With regard to purchase orders, the agreed particulars shall prevail. ABB does not accept any responsibility whatsoever for potential errors or possible lack of information in this document.

We reserve all rights in this document and in the subject matter and illustrations contained therein. Any reproduction, disclosure to third parties or utilization of its contents – in whole or in parts – is forbidden without prior written consent of ABB.