



NXF4000

FUEL AIR RATIO CONTROLLER with INTEGRATED FLAME SAFEGUARD



DESCRIPTION

Fireeye NXF4000, the newest member of the Nexus family, is a state of the art parallel positioning system with integrated flame safeguard for all types of liquid or gaseous fuel fired combustion systems. The NXF4000 offers the most compact and advanced parallel positioning system available. Four fuel profiles allow the NXF4000 to accommodate a variety of applications such as two fuels, with and without, the optional variable frequency/speed drive (VFD/VSD). With each profile having up to 24 points entered to assure a smooth combustion “curve”, the microprocessors within the NXF4000 interpolate points between entered values and precisely position fuel and air servos to within ± 0.1 degree, and the VFD to within 0.1% of its full scale range. The result is improved efficiency by eliminating hysteresis typically found in slide wire or single point positioning systems. Additional gains in burner efficiency can be realized by adding the optional (VFD/VSD) drive board and Fireeye O₂ probe. The NXF4000 is capable of controlling a total of ten servo motors, four servos per profile. All servo motors and displays operate on a secure communications protocol and can be “daisy chained”/ multi-dropped together for simplified wiring. Available servos from Fireeye have torque ranges of 4 Nm (3 ft./lb.), 20 Nm (15 ft./lb.), and 50 Nm (37 ft./lb.). Two independent PID control loops for temperature or pressure control provide precise, accurate control of firing rate for unmatched response to load changes. Fifteen safety rated user definable line voltage inputs are standard and can be configured for functions such as burner on, setpoint select, lead lag, setback, etc. The NXF4000 also contains programmable relays that can be used for various functions throughout the burner sequence. Built in lead lag sequencing for up to six boilers is included in every NXF4000. The NXF4000 contains an SD (Secure Digital) card for profiles & parameters upload/download capability.

The User Interface, NXD410, contains a tactile feel keypad and a four line backlit LCD screen. The NXD410 offers dedicated keys that facilitate various everyday tasks done by the boiler operator. Among these are C-MODE, BURNER ON/OFF, ADJUST SETPOINT, LOW FIRE, AUTO/MAN (modulation) and LEAD LAG (sequencing). This eliminates the tedious task of entering various modes and passcodes to search for the desired parameter. The NXD410 has a HOME screen that shows four lines of instant and pertinent information about the current state of the burner. A HOME key on the keypad will direct the user to this screen from anywhere within the menu system. An intuitive menu system and easy to use navigation keys optimally placed on the keypad provide an easy flow to all parameters in the system. An INFO key is available that allows the installer/operator to quickly check key system values while in commissioning mode. The FAULT key provides quick access to last 10 fault history. The NXD410 is panel mount only and is rated for NEMA 4X indoor environments.

When required, the operating system of the NXF4000 and NXD410 will automatically direct the user to the passcode setup screen and when entered correctly will take the user directly to the parameter requested, making the entire system user-friendly.



Key features of the NXF4000 system

- Four line user interface with direct key functions
- 7" and 13" Touchscreen support
- Capable of controlling up to 10 servos
- Non-monotonic servo operation
- All-in-one control, with FSG daughtercard.
- Two independent VFD control channels with encoder inputs
- Available UV, IR & Integrated flame scanners
- 15 line voltage user-defined digital inputs
- Voltage free alarm relay contacts (normally open in non-lockout state)
- Four user selected line voltage burner profiles
- Five 4-20 mA analog transducer inputs
- POC/FVES proving support
- Cold start thermal shock protection limits mechanical stress
- Assured low fire cutoff
- Intelligent valve proving for double-block valve setup, with pilot and vent.
- Sequencing for up to 6 boilers
- SD (Secure Digital) interface for backup and restore
- 16GB SDCARD media included
- Airflow switch proving
- Modbus-RTU communications via RS485 with read/write capability
- PID operation for precise process control
- Intuitive menu driven design
- User defined 4-20 mA outputs
- Three programmable relay outputs
- Optional O2 trim
- Track Modulation
- Boiler efficiency calculation
- Small footprint: 5.0"(127mm) W x 8.0"(203.2mm) H x 4.0"(101.6mm) D
- No wiring base necessary
- Expert support from the Fireye team

A minimal Nexus system includes the NXF4000 parallel positioning controller, FSG daughtercard, Flame scanner, NXD410 User Interface or touchscreen, appropriate Fireye pressure and/or temperature transducers, and a minimum of one servos. Optionally an O2 probe and (VFD/VSD) card can be added.



WARNING: Electro-mechanical high steam pressure or high water temperature limits must remain in the running interlock circuit of the NXF4000.

This manual describes the installation, commissioning, operation and maintenance of the NXF4000 series fuel air ratio controls. It may be used in conjunction with the following other manuals:

- NEXBK-1000 - Nexus bracket and coupling accessories
- NEX-3004 - Nexus FX04 series 4Nm servo motor
- NEX-3020 - Nexus FX20 series 20Nm servo motor
- NEX-3050 - Nexus FX50 series 50Nm servo motor
- NXCESO2-1001 - OXYGEN PROBE
- 133-750 - O2 mounting flange installation instructions
- NXD-4101 - NXD410 User Interface
- NXCESVFD - VFD plug-in board installation
- NXCESAMP-1001 - FSG plug-in board installation
- NXTSD-4001 - Touchscreen user's guide
- FXIATS-1 - Ambient air temperature transmitter
- BLZPTS-1 - Pressure and temperature sensors
- CU-95 - Insight 1 Integrated Flame Scanner
- CU-113 - Insight 2 Integrated Flame Scanner
- CU-114 - Phoenix Integrated Flame Scanner



WARNING: Failure to properly install, operate, or commission the equipment in this manual could result in significant property damage, severe injury, or death. It is the responsibility of the owner or user to ensure that the equipment described is installed, operated and commissioned in compliance with this manual and other system component manuals, as well with all applicable national and local codes.



WARNING!!!



Boiler operation, maintenance, and troubleshooting shall only be conducted by trained personnel. Persons troubleshooting lockouts or resetting the control must respond properly to troubleshooting error codes as described in this product bulletin.

Jumpers being used to perform static test on the system must only be used in a controlled manner and must be removed prior to the operation of the control. Such tests may verify the external controllers, limits, interlocks, actuators, valves, transformers, motors and other devices are operating properly. Such tests must be conducted with manual fuel valves in the closed position only. Replace all limits and interlocks not operating properly, and do not bypass limits in interlocks. Failure to follow these guidelines may result in an unsafe condition hazardous to life and property.



TABLE OF CONTENTS

Description	1	Flue Temperature Alarm Limits	71
Key Features Of The NXF4000 System	2	Gain Terms.....	72
NXF4000 System Specifications.....	5	Understanding O2 Error Codes.....	72
Approvals.....	8	Commissioning Procedure:	74
Part Numbers and Approvals.....	9	Profile Setpoints	74
Ordering Information.....	11	Commissioning Rules.....	75
Installation Procedure	14	Commissioning O2 Trim with the Oxygen Probe.....	81
NXD410 User Interface.....	14	Operation with O2 Trim	82
Installation of VFD and Flame Amplifier Daughtercards.....	19	Adjust Ratio Procedure.....	83
NXF4000 Installation.....	21	Boiler Efficiency.....	85
Wiring Connections.....	25	Cold Start Thermal Shock Protection	85
NXF4000 Mounting and Wiring.....	27	Communications Setup	87
Pressure and Temperature Sensors.....	27	Setback Operation.....	88
Wiring Pressure and Temperature Sensors.....	29	Standby Water.....	89
Flame Scanners.....	30	Track Modulation.....	90
Installation - UV Scanners	30	Valve Proving	91
Servo Motor Setup and Wiring.....	38	Calculating Test Times.....	94
Cables and Connectors	39	Operating Sequence.....	96
NXCES02 Oxygen Probe.....	40	NXF4000 System Wiring Diagram.....	97
NXD410 User Interface.....	42	Boiler Sequencing	99
Keypad Setup	42	Master Select Method.....	100
Navigating Through Display Menus	43	Operation Notes:	102
NXF4000 Control Operation	45	Sequencing Configuration Example	103
Passcode	46	Info Screen	105
Real Time Clock.....	46	SD Card Operation	108
Servo Setup	47	Backup Operation.....	108
Sensor Setup	49	Restore Operation	110
Sensor Setpoint Setup.....	50	Delete Operation	111
Profile Setup	53	Format Operation	112
Burner Control Setup	53	NXF4000 Operation after a Restore.....	112
Digital Input Setup.....	56	Profile Setup Work Sheet	113
User Output Setup	60	Lockouts:	115
Variable Frequency Drive	62	Error Messages:	116
Encoder Input.....	64	O2 Probe Field Calibration Instruction.....	124
Commissioning With VFD.....	66	Marginal Alarms.....	124
Analog Out Setup.....	66	Fault History	124
Oxygen Probe Setup.....	67	Notice	126
Setting Trim Limits	69	Warranties	126
General Rules for O ₂ Alarm Notification	70		



NXF4000 SYSTEM SPECIFICATIONS

NXF4000 Control:

Supply Voltage:

NXF4000 120 VAC 50/60 Hz, single phase

NXF4000-230V 230 VAC 50/60 Hz, single phase

Power Consumption: 15 VA

Temperature Rating:

Operating: 32°F to 140°F (0°C to 60°C)

Storage: -4°F to 158°F (-20°C to 70°C)

Humidity Rating: 85% RH, non-condensing

Protection Category: NEMA 1 (IP10)

Unit Dimensions: 5.0" (127 mm) W x 8.0" (203.2mm) H x 4.0" (101.6mm) D

Shipping Weight: Approx. 3.2 lbs. (1.45 kg)

NXD410 User Interface:

Supply Voltage: 24 VDC @ 250 mA (supplied by NXF4000)

Power Consumption: 6 VA

Temperature Rating:

Operating: 32°F to 140°F (0°C to 60°C)

Storage: -4°F to 158°F (-20°C to 70°C)

Humidity Rating: 85% RH, non-condensing

Protection Category: NEMA 4X indoors only, IP65

Unit Dimensions: Panel Cutout: 5.35 (136mm)W x 3.78 (96mm)H

Shipping Weight: Approx. 1.0 lbs. (.45 kg)

NXTSD407 Touchscreen Interface:

Supply Voltage: 24 VDC @ 0.65A

Power Consumption: 15.6 VA

Temperature Rating:

Operating: 32°F to 122°F (0°C to 50°C)

Storage: -4°F to 158°F (-20°C to 70°C)

Humidity Rating: 85% RH, non-condensing

Protection Category: NEMA 4X indoors only, IP66 (front)

Unit Dimensions: Panel Cutout: 7.36 (187mm)L x 5.79 (147mm)H

Shipping Weight: Approx. 2.2 lbs. (1 kg)

NXTSD413 Touchscreen Interface:

Supply Voltage: 24 VDC @ 1.15A

Power Consumption: 27.6 VA

Temperature Rating:

Operating: 32°F to 122°F (0°C to 50°C)

Storage: -4°F to 158°F (-20°C to 70°C)

Humidity Rating: 85% RH, non-condensing



Protection Category: NEMA 4X indoors only, IP66 (front)

Unit Dimensions: Panel Cutout: 13.22 (336mm)L x 10.51 (267mm)H

Shipping Weight: Approx. 6.2 lbs. (2.8 kg)

NXCESO2 Oxygen Probe:

Supply Voltage: 24 VDC \pm 10%

Power Consumption: 27 VA, 13 VA (steady state)

Temperature Rating:

Operating: 32°F to 140°F (0°C to 60°C)

Storage: -4°F to 158°F (-20°C to 70°C)

Humidity Rating: 85% RH, non-condensing

Protection Category: NEMA 1 (IP01)

Unit Dimension: see Figure 6 on page 42

Shipping Weight:

NXCESO2-8: 8.1 lbs (3.67 kg)

NXCESO2-16: 9.2 lbs (4.17kg)

FXCESO2 Oxygen Probe with Oxygen Trim Interface:

Supply Voltage: 24 VDC \pm 10%

Power Consumption: 27 VA, 13 VA (steady state)

Temperature Rating:

Operating: 32°F to 140°F (0°C to 60°C)

Storage: -4°F to 158°F (-20°C to 70°C)

Humidity Rating: 85% RH, non-condensing

Protection Category: NEMA 1 (IP20) for FXCESO2

: NEMA 4 (IP65) for FXO2TRIM

Shipping Weight:

FXCESO2-8: 5.5 lbs (2.5kg)

FXCESO2-16: 7.7lbs (3.5kg)

FXCESO2-30: 9.9lbs (4.5kg)

FXO2TRIM-1: 1.32lbs (0.6kg)

Servos:

Supply Voltage:

FX04: 24 VDC \pm 10%

FX20: 24 VDC \pm 10%

FX50: 24 VDC \pm 10%

Power Consumption (Peak):

FX04: 5 VA Nominal, 7.5 VA peak

FX20: 15 VA nominal, 35 VA peak

FX50: 20 VA nominal, 38 VA peak



Temperature Rating:

Operating: -4°F to 140°F (-20°C to 60°C)
Storage: -4°F to 158°F (-20°C to 70°C)
Humidity Rating: 85% RH, non-condensing

Protection Rating: NEMA 4, IP65

Torque Rating:

FX04: 4 Nm, 3.0 ft./lb.
FX20: 20 Nm, 15 ft./lb.
FX50: 50 Nm, 37 ft./lb.

Rotational Span: 1 degree to 99.9 degrees

Actuating time of 90 degree rotation: min = 30 seconds, max = 120 seconds

Repeatability: 0.3 degree | **Hysteresis:** 0.6 degree

Shipping Weight:

FX04: Approx. 2.27 lbs (1.1 kg)
FX20: Approx. 5.43 lbs (2.5 kg)
FX50: Approx. 6.10 lbs (2.77 kg)

Temperature Sensors:

Temperature Measurement Range:

FXIATS-140: -40°F to 140°F (-40°C to 60°C) - see FXIATS-1 bulletin for technical info
TS350-X: 32°F to 350°F (0°C to 176°C)
TS752-X: 32°F to 752°F (0°C to 400°C)

RTD Type: Platinum, 100 ohms \pm 0.1% @32°F (0°C)

Temperature Coefficient: .00385 ohms/°C

Output: 4-20 mA, linear with temperature

Operating Temperature Range: -13°F to 185°F (-25°C to 85°C)

Accuracy: \pm 0.75% of span

Thermowell Case: 300 Series stainless steel

Mechanical Fittings: 1/2"-14 NPT

Pressure Sensors:

Pressure Measurement Range: 0 to 15, -14.7 to 25, 0 to 30, 0 to 200, 0 to 300 PSI

Excitation Voltage: 9-30Vdc (supplied by NXF4000 control)

Accuracy: \pm 0.25% Full Scale (at 25°C)

Output: 4-20 mA, linear with pressure

Maximum Over Pressure: 200% of full scale

Maximum Burst Pressure: 800% of full scale

Operating Temperature Range: -40°F to 185°F (-40°C to 85°C)

Fitting: 1/4" NPT Male

Electrical: 1/2" Conduit and Terminal Strip



WARNING: This equipment generates and can radiate radio frequency energy, and if not installed and used in accordance with the instruction manual may cause interference to radio communications. It has been tested and found to comply with the limits for a Class A computing device pursuant to Subpart J of part 15 of FCC Rules, which are designed to provide reasonable protection against such interference when operated in a commercial environment. Operation of this equipment in a residential area is likely to cause interference in which case the user, at his own expense, is required to take what-ever measures which may be required to correct the interference.

APPROVALS

Underwriter's Laboratories Inc.:

File MCCZ.MP1537

Controls, Primary Safety

File MCCZ7.MP1537

Controls, Primary Safety Certified for Canada

CE:

(PIN) 0063CT1349







EN 298:2012, EN 1643:2014, prEN 12067-2:2016, EN 14459:2007







DIN CERTO:

Registration Number : 5F251

PART NUMBERS AND APPROVALS

Table 1: Agency Approvals

Fireye Part Number						
Control						
NXF4000		X		X		X
NXF4000-230V				X		X
FSG Daughtercards						
NXCESUV		X		X		X
NXCESIR		X		X		X
NXCESDC		X		X		X
User Interface						
NXD410		X		X		X
NXTSD407		X		X		X
NXTSD413		X		X		X
Servos						
FX04, FX04-1	X	X	X	X		X
FX20, FX20-1	X	X	X	X		X
FX50, FX50-1	X	X	X	X		X
Oxygen Probe						
NXCES02-8		X				
NXCES02-16		X				
FXCES02-8				X		X
FXCES02-16				X		X
FXCES02-30				X		X
FXCO2TRIM-1				X		X
Transducers						
BLPS-15	X	X		X		X
BLPS-25	X	X		X		X
BLPS-30	X	X		X		X
BLPS-200	X	X		X		X
BLPS-300	X	X		X		X
TS350-2, -4, -8	X	X		X		X
TS-752-2, -4, -8	X	X		X		X

Fireye Part Number						
FXIATS-140		X		X		X

X = CERTIFICATION IN HAND



ORDERING INFORMATION

Control	
NXF4000	Advanced burner management System, with Parallel positioning, 120 VAC input.
NXF4000-230V	Advanced burner management System, with Parallel positioning, 230 VAC input.
129-190	Kit, fan replacement
Daughter Card	
NXCESUV	FSG Plug-in card, UV application.
NXCESIR	FSG Plug-in card, IR application.
NXCESDC	FSG Plug-in card, Direct-Couple interface for use with Integrated scanners or Flame-switches.
NXCESVFD	VFD Plug-in card, provides variable frequency (VFD/VSD) capability
Display	
NXD410	User Interface with keypad, 24 VDC operation, 4 line back lit LCD display, panel mount only, includes mounting brackets.
59-562-2	Cable assembly, 10 feet length, for interfacing NXD410 to NXF4000
NXTSD407	7" TFT wide color Touchscreen display, 800x480 pixel (WVGA) resolution, LED backlight, 24VDC, includes mounting brackets
NXTSD413	13.3" TFT wide color Touchscreen display, 1280x800 pixel (WVGA) resolution, LED backlight, 24VDC, includes mounting brackets. <i>EMC emission requirements shall be tested after the incorporation of the NXTSD413 touchscreen into the burner control system.</i>
129-196-2	Replacement cable kit. Contains one 12' communications, one 12' power cable, and DB9 connector plug.
Servos	
FX04	Servo motor, 24 VDC operation, 4Nm, 3 lb.-ft. torque, without connectors, accepts 1/2 inch NPT fitting, minimum travel time of 30 seconds for 90°
FX04-1	Servo motor, 24 VDC operation, 4Nm, 3 lb.-ft. torque, with connectors, minimum travel time of 30 seconds for 90°
FX20	Servo motor, 24 VDC operation, 20Nm, 15 lb.-ft. torque, without connectors, accepts 1/2 inch NPT fitting, minimum travel time of 30 seconds for 90°
FX20-1	Servo motor, 24 VDC operation, 20Nm, 15 lb.-ft. torque, with connectors, minimum travel time of 30 seconds for 90°
FX50	Servo motor, 24 VDC operation, 50Nm, 37 lb.-ft. torque, without connectors, accepts 1/2 inch NPT fitting, minimum travel time of 30 seconds for 90°
FX50-1	Servo motor, 24 VDC operation, 50Nm, 37 lb.-ft. torque, with connectors, minimum travel time of 30 seconds for 90°
Servo Cables	
59-565-6	Cordset, 6 feet, 1/2" NPT connectors on both ends, PVC jacket, temperature rating -40°C to 105°C, meets NEMA 1,3,4,6P and IEC67
59-565-40	Cordset, 40 feet, 1/2" NPT connectors on both ends, PVC jacket, temperature rating -40°C to 105°C, meets NEMA 1,3,4,6P and IEC67
Connector Kit	
129-192	Connector, field wireable. Used for FX04-1, FX20-1, FX50-1 servos with connectors. Use cable 59-565
129-194	Male quick disconnect to convert non connector type FX series servos.
59-565	Cable, 1 twisted pair, 2 power wires, suitable for servo and Oxygen probe hookup.
O2 Probe	
NXCES02-8, -16	O2 probe assembly, insertion length is 8, 16 inches Add "-KIT" to O2 probe part number to get the full kit consisting of O2 Probe, mounting flange, and FXIATS-140 sensor
NXCES02P42	Cartridge, probe replacement
FXCES02-8, -16, -30	O2 probe assembly, high stack temperature application, insertion length is 8, 16, 30 inches. Must use with FXO2TRIM-1 and 59 612-33 cable kit.
FXO2TRIM-1	Type 2 O2 Trim Interface Module
59-612-33	Interconnection cable pack: Sensor cable, Thermocouple cable, and conduit -- 33ft (10m)
35-381-2	Flange, O2 probe mounting
129-189	Cover, mounting flange



Control	
BLPS-15, -25, -30	Pressure transducer, 0 to15 PSI (0 to 1030 mb), -14.7 to 25 PSI (-1013 to 1720 mb), 0 to 30 PSI (0 to 2070 mb), 4-20 mA output linear with pressure. ¼" NPTF mounting. Screw terminal connections and conduit adapter cover.
BLPS-200	Pressure transducer, 0 to 200PSI (0 to 13.8 Bar), 4-20 mA output linear with pressure. ¼" NPTF mounting. Screw terminal connections and conduit adapter cover.
BLPS-300	Pressure transducer, 0 to 300 PSI (0 to 20.7 Bar), 4-20 mA output linear with pressure. ¼" NPTF mounting. Screw terminal connections and conduit adapter cover.
Temperature Transducers	
TS350-2, -4, -8	Temperature sensor, Range 32°F to 350°F (0°C to 176°C), 4-20 mA output, linear with temperature. Insertion length is 2, 4, 8 inches. Stainless steel thermowell included.
TS-752-2, -4, -8	Temperature sensor, Range 32°F to 752°F (0°C to 400°C), 4-20 mA output, linear with temperature. Insertion length is 2, 4, 8 inches. Stainless steel thermowell included.
FXIATS-140	Ambient air temperature transmitter, -40°F to 140°F, 4-20mA output, 7 to 40VDC, NEMA enclosure
Scanner Selection	
UV Scanners	
UV90L-1	UV scanner, front and side viewing, terminal block
UV5-1	UV scanner, front and side viewing, 78" (2000mm) flying leads
UV1AL-3	UV scanner, 1/2" NPT, 36" (915mm) shielded leads
UV1AL-6	UV scanner, 1/2" NPT, 72" (1830mm) shielded leads
4-742-1	Replacement tube for UV90L-1
IR Scanners	
48PT2-1003	Infrared scanner, 1/2" straight mount, 96" (2438mm) TC-ER Cable
48PT2-1007	Infrared scanner, 1/2" straight mount, 48" (1219mm) TC-ER Cable
48PT2-9003	Infrared scanner, 90 degree angle mount, 96" (2438mm) TC-ER Cable
48PT2-9007	Infrared scanner, 90 degree angle mount, 48" (1219mm) TC-ER Cable
4-263-1	Replacement photo detector
Phoenix Integrated Scanner	
85UVF4-1QDWR	Phoenix Integrated Scanner, 4 sec FFRT – Ultra-violet with 8-pin electrical quick disconnect. FM, UL_CUS approved.
85UVF4-2QDWR	Fiber optic version of standard Phoenix Integrated Scanner, 4 sec FFRT – Ultra-violet with 8-pin electrical quick disconnect. FM, UL_CUS approved.
85IRF4-1QDWR	Phoenix Integrated Scanner, 4 sec FFRT – Infrared with 8-pin electrical quick disconnect. FM, UL_CUS approved.
85IRF4-2QDWR	Fiber optic version of standard Phoenix Integrated Scanner, 4 sec FFRT – Infrared with 8-pin electrical quick disconnect. FM, UL_CUS approved.
35-318-1	Mounting flange for Phoenix, 1" NPT
35-318-2	Mounting flange for Phoenix, 1" BSP
59-546-3	8-Conductor 3-meter (9 ft. 10 in.) cable assembly with 8-pin female connector.
59-546-6	8-Conductor 6-meter (19 ft. 8 in.) cable assembly with 8-pin female connector.
59-546-9	8-Conductor 9-meter (29 ft. 3 in.) cable assembly with 8-pin female connector.
59-546-12	8-Conductor 12-meter (39 ft. 4 in.) cable assembly with 8-pin female connector.
59-546-15	8-Conductor 15-meter (49 ft. 2 in.) cable assembly with 8-pin female connector.
59-546-30	8-Conductor 30-meter (98 ft. 5 in.) cable assembly with 8-pin female connector.
59-546-45	8-Conductor 45-meter (147 ft. 7 in.) cable assembly with 8-pin female connector.
59-546-60	8-Conductor 60-meter (196 ft. 10 in.) cable assembly with 8-pin female connector.
59-546-90	8-Conductor 90-meter (295 ft. 3 in.) cable assembly with 8-pin female connector.
Insight Integrated Scanner	
95IRS2-1, 2	Enhanced Model InSight Scanner – Infrared with quick disconnect, FM, UL_CUS approved.
95UVS2-1, 2, 3	Enhanced Model InSight Scanner – Ultra-violet with quick disconnect, FM, UL_CUS approved.
95DSS2-1	Enhanced Model InSight Scanner – Dual detector with quick disconnect, FM, UL_CUS approved.
95DSS3-1WINC	Enhanced Model InSight2 Scanner – Dual detector with quick disconnect, FM, UL_CUS approved.



INSTALLATION PROCEDURE

- 1) A UL listed & CE approved combustion efficiency system is comprised of the following items.
 - a) NXF4000, fuel/air ratio controller w/FSG daughtercard
 - c) NXD410, NXTSD407, or NXTSD413 user interface
 - d) FX series servos
- 2) Wiring must comply with all applicable codes, ordinances and regulations.
- 3) **Wiring must comply with NEC Class 1 (Line Voltage) wiring.**
- 4) To minimize interference from radio frequency energy generated by the NXF4000 control, it is necessary that all control wiring be placed in conduit. It is recommended that all low voltage signal wiring, i.e. servos, O2 probe, pressure/temperature transducer be placed in a separate conduit from line voltage wiring, i.e. relay outputs, line voltage digital inputs, profile select.
- 5) Limit switches, interlocks and relay outputs must be rated to simultaneously carry and break current to the ignition transformer, pilot valve(s) and main fuel valve(s) of the NXF4000.
- 6) Recommended wire routing of lead wires:
 - a) Do not run high voltage ignition transformer wires in the same conduit with any other wires.
 - b) Do not route analog transducer cables, display communication cables, modbus cables or servo motor cable in conduit with line voltage circuits. Use separate conduit where necessary.
- 7) Maximum wire lengths:
 - a) Terminal inputs (Operating limits, interlocks, valves, etc.): 200 feet. (61 meters).
 - b) Line voltage inputs: 500 feet (152 meters) to a normally open remote reset push-button, but should remain within sight and sound of the burner.
 - c) Modbus communications RS-485: 1000 ft (305 meters) for baud rates of 19.2kbps & below.
 - d) Servo & O2 probe: 200 feet (61 meters)
 - e) Sensors: 100 feet (30 meters)

A good ground system should be provided to minimize the effects of AC quality problems. A properly designed ground system meeting all the safety requirements will ensure that any AC voltage quality problems, such as spikes, surges and impulses have a low impedance path to ground. A low impedance path to ground is required to ensure that large currents involved with any surge voltages will follow the desired path in preference to alternative paths where extensive damage to equipment may occur.

NXD410 User Interface

The NXD410 is a panel mounted device. The device includes a gasket that must be properly seated to assure NEMA 4X (IP65) rating. Packed with every NXD410 device is a gasket and remote mounting bracket kit (not sold separately) containing four bracket assemblies as shown.

FIGURE 1. Mounting Kit

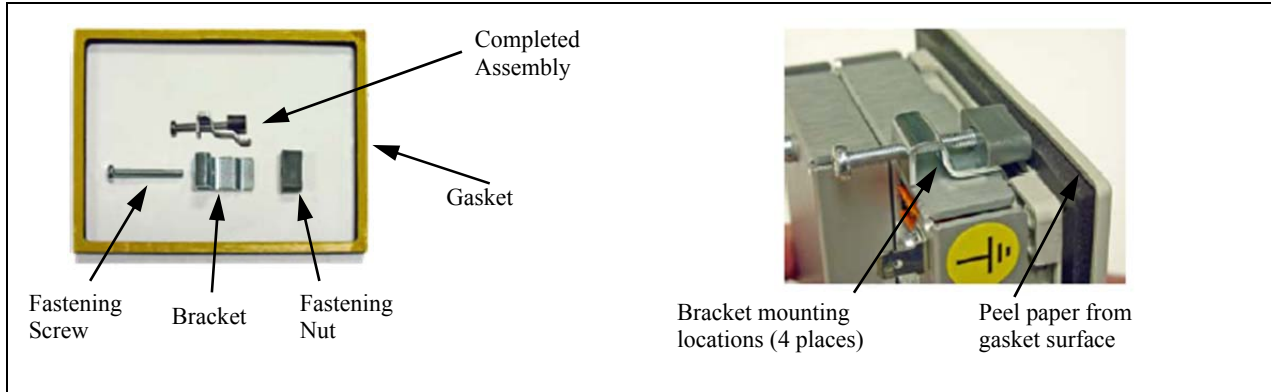

The bracket assembly mounts from the rear of the display with the fastening nut against the backside of the panel. Use the following dimensions for the panel cutout.

FIGURE 2. Panel Cutout

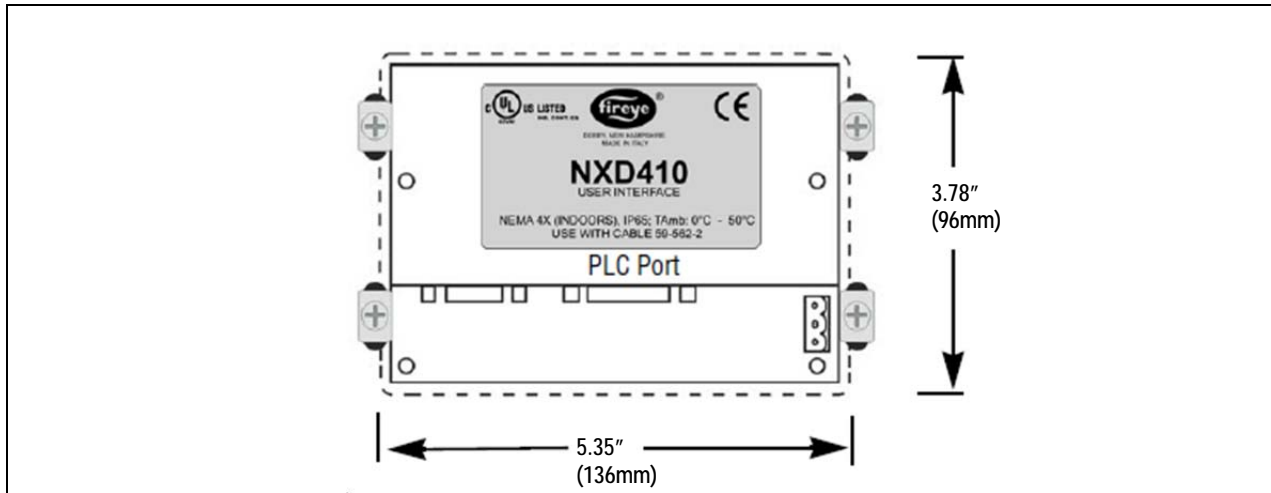

Use Fireye cable, part number 59-562-2 to connect from the NXD410 to the NXF4000 control. The DA15-FM connector plugs into the PLC port located on the backside of the NXD410. The cable distance from the NXF4000 to the NXD410 is limited to 10 feet (3 meters) wire run.

FIGURE 3. NXD410 Rear View

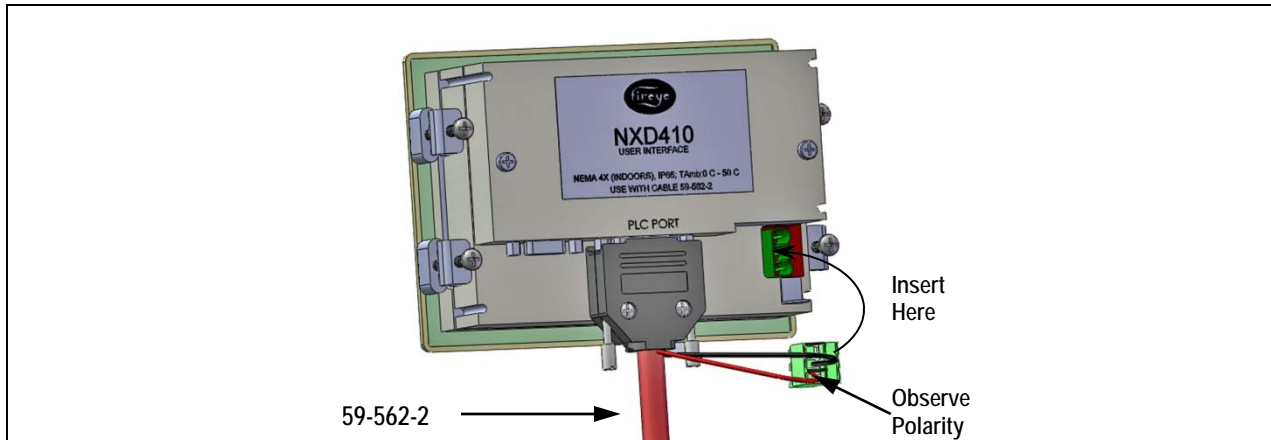

The bottom edge of the display must be mounted at least two inches from any cabinet door edge to allow sufficient clearance for the 59-562-2 cable.

FIGURE 4. TOUCHSCREEN PANEL CUTOUT

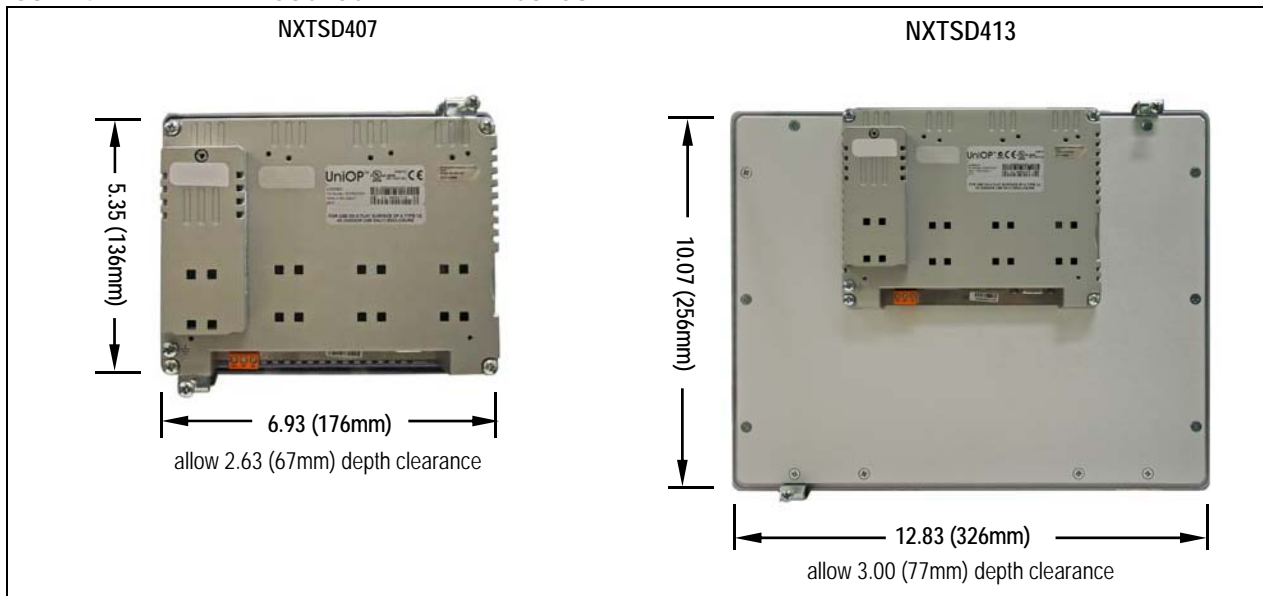

The bottom edge of the display must be mounted at least two inches from any cabinet door edge to allow sufficient clearance for the cables.

FIGURE 5. TOUCHSCREEN REAR VIEW

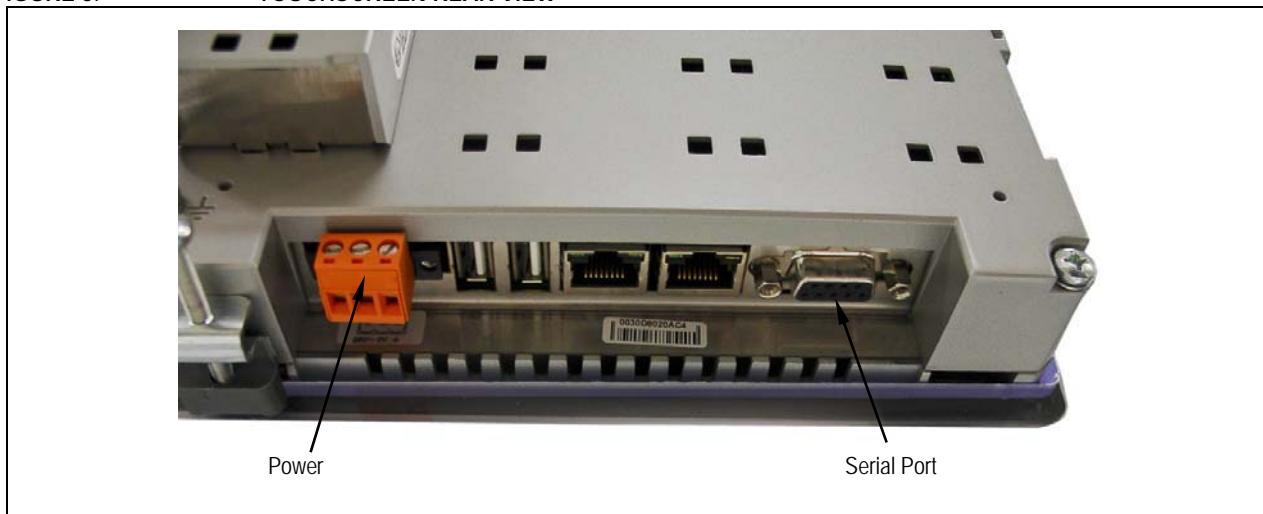

NXTSD4xx CONNECTION TO NXF4000

The included cable accessories consist of: (59-583) one 22 AWG cable for communications and (59-582) one 18 AWG cable for power

FROM 59-582	TO PPC4000	Description
RED	P2.1	24 VDC POWER
BLACK	P2.4	24 VDC RETURN
WHITE	CHASSIS	EARTH GROUND
FROM 59-583		
WHITE	P12.1	Modbus A
RED	P12.2	Modbus B
BLACK	P11.1	REF GND
DRAIN	CHASSIS	EARTH GROUND

FIGURE 1. 12 Ft Signal Cable (59-583 gray)

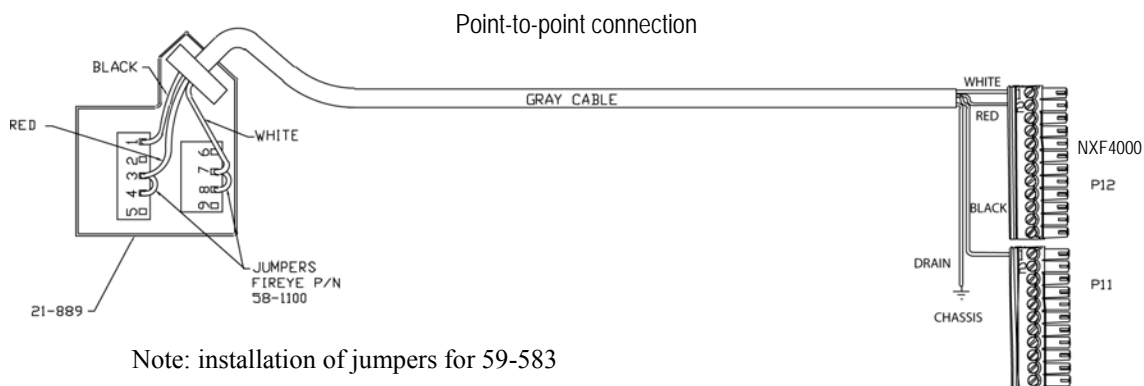

Note: installation of jumpers for 59-583

Note: There is a maximum amount of power that may be supplied by the NXF4000 to externally connected peripherals, including the touchscreen user interface. Please refer to the NXF4001 bulletin for details.

The Touchscreen display is considered the Modbus master and it can address up to six NXF4000 in a daisy chain fashion. Only the touchscreen can be a master on the Modbus chain.

FIGURE 12 Ft Signal Cable (59-583 gray)

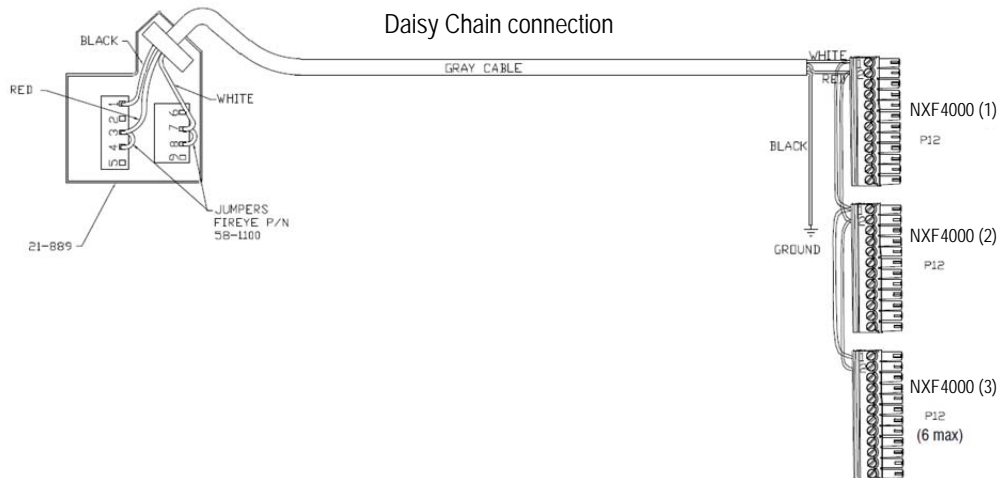

FIGURE 2. 12 Ft Signal Cable (59-583 blue)

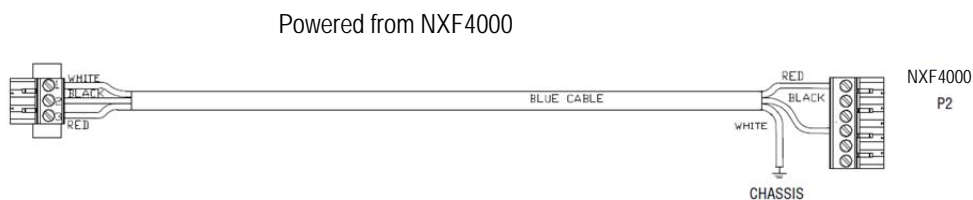

FIGURE 3. 12 Ft Signal Cable (59-583 blue)





The NXF4000 is mounted to the cabinet back plate using 4 X #8-32 screws. Following the mounting dimensions shown in Figure 4, drill and tap 4 mounting holes. Firmly screw the control to the cabinet back plate.

INSTALLATION OF VFD and FLAME AMPLIFIER DAUGHTERCARDS

The VFD and Flame Amplifier daughtercards are sold separately and they require field installations. Depending on the requirements of the installation, the VFD daughtercard may be left uninstalled.

The installation of the flame amplifier daughtercard is mandatory.



WARNING: Proper ESD practices should be applied when handling or installing the daughtercards. Ensure that electric power is turned off. Refer to SN-100 for recommended grounding techniques. Be aware that power to some interlocks (operating controls, air flow switches, modulating circuits, etc.) may be derived from sources other than the NXF4000.

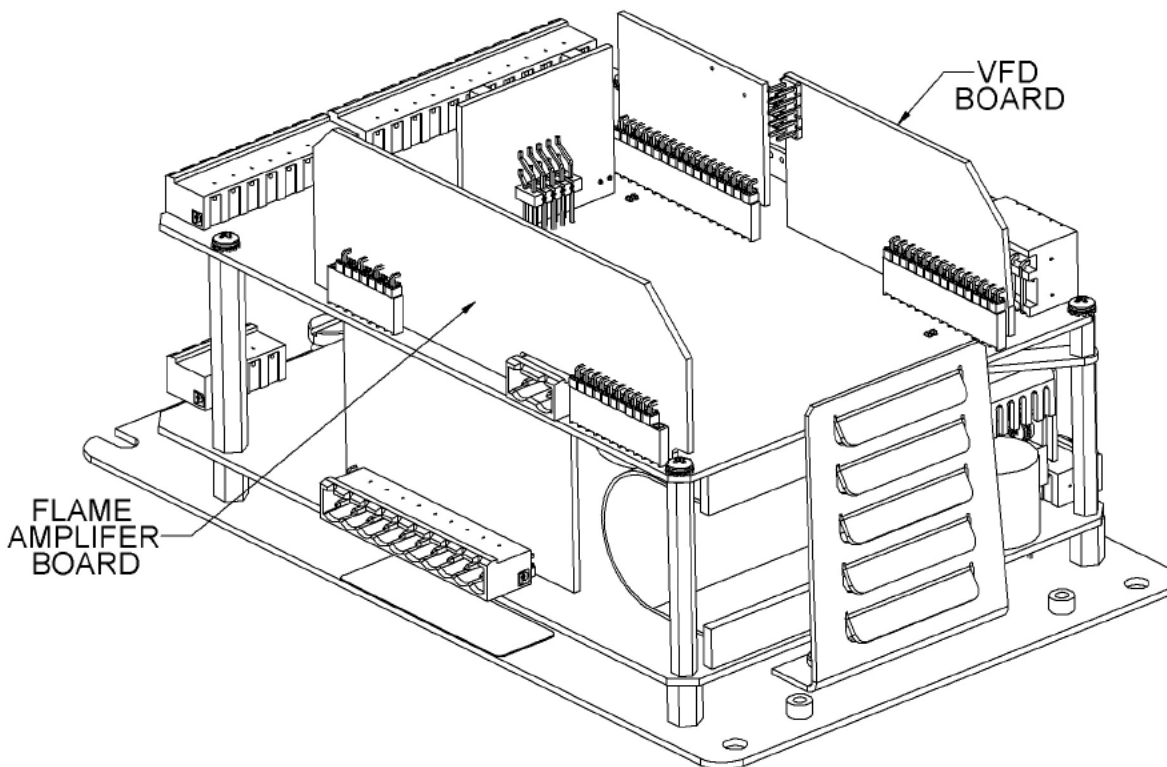

NXF4000
SHOWN WITHOUT COVER

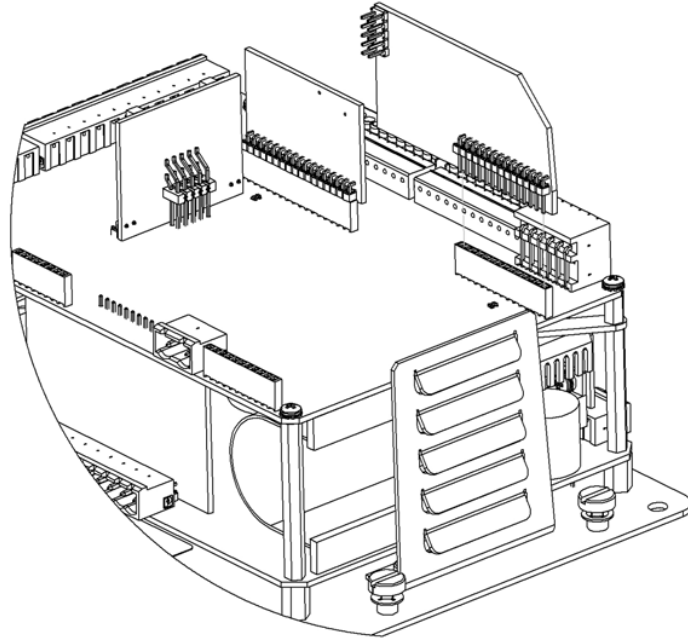

VFD BOARD
INSTALLATION

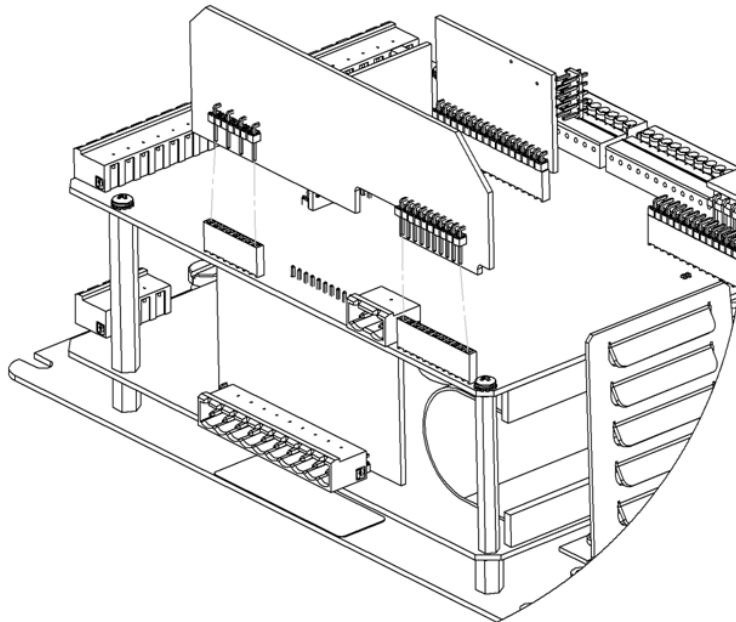

FSG BOARD
INSTALLATION

NXF4000 INSTALLATION

Install the NXF4000 control where the relative humidity never reaches the saturation point. The Nexus NXF4000 system is designed to operate in a maximum 85% relative humidity continuous, non-condensing environment. Do not install the NXF4000 system where it can be subjected to vibration in excess of 0.5G continuous maximum vibration. The NXF4000 system is not a weather tight enclosure. The standard vertical position is recommended. Allow at least two inches clearance around the control for service and installation.

Refer to Figure 4 for mounting dimensions.

FIGURE 4. Mounting Dimensions

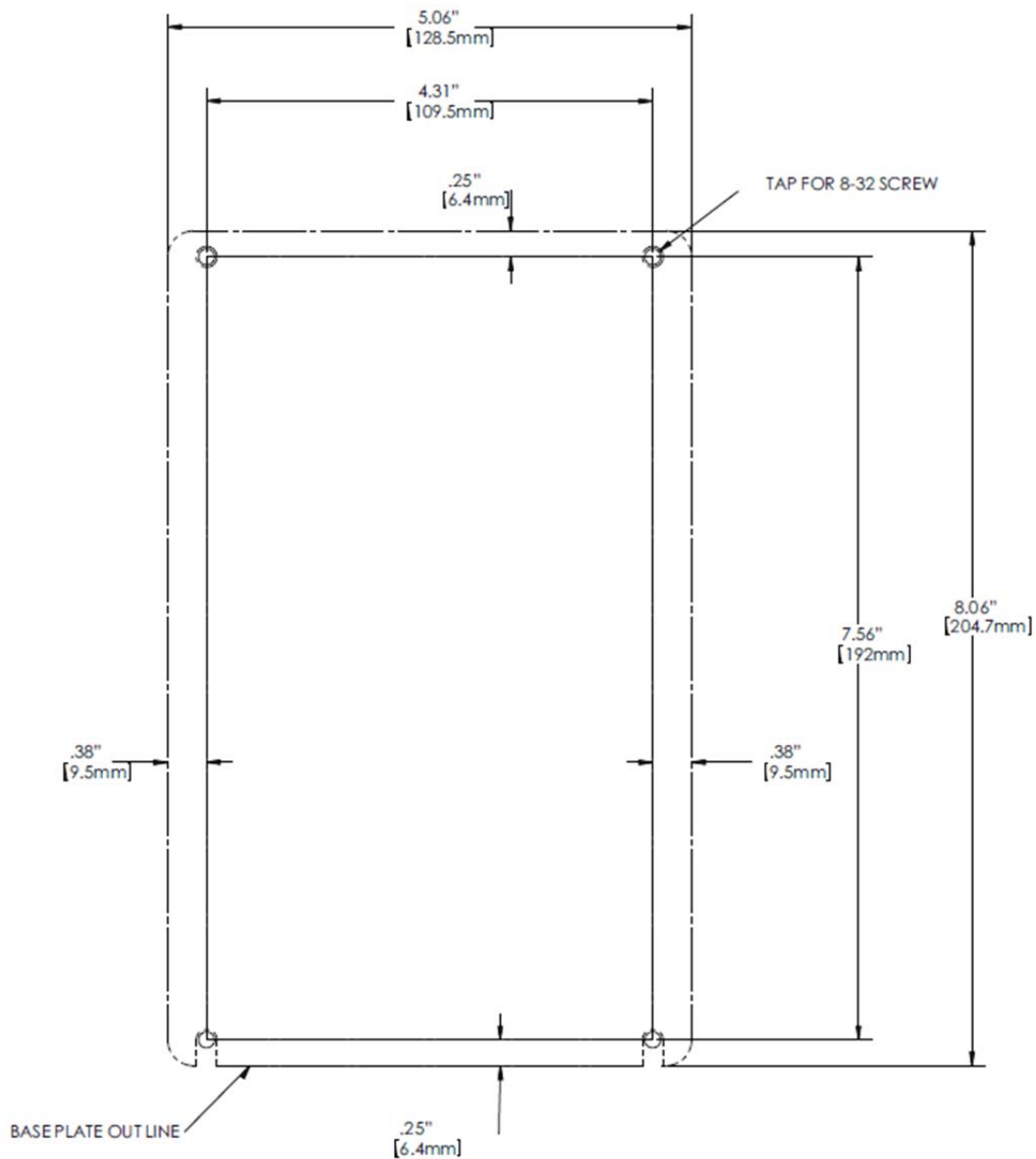

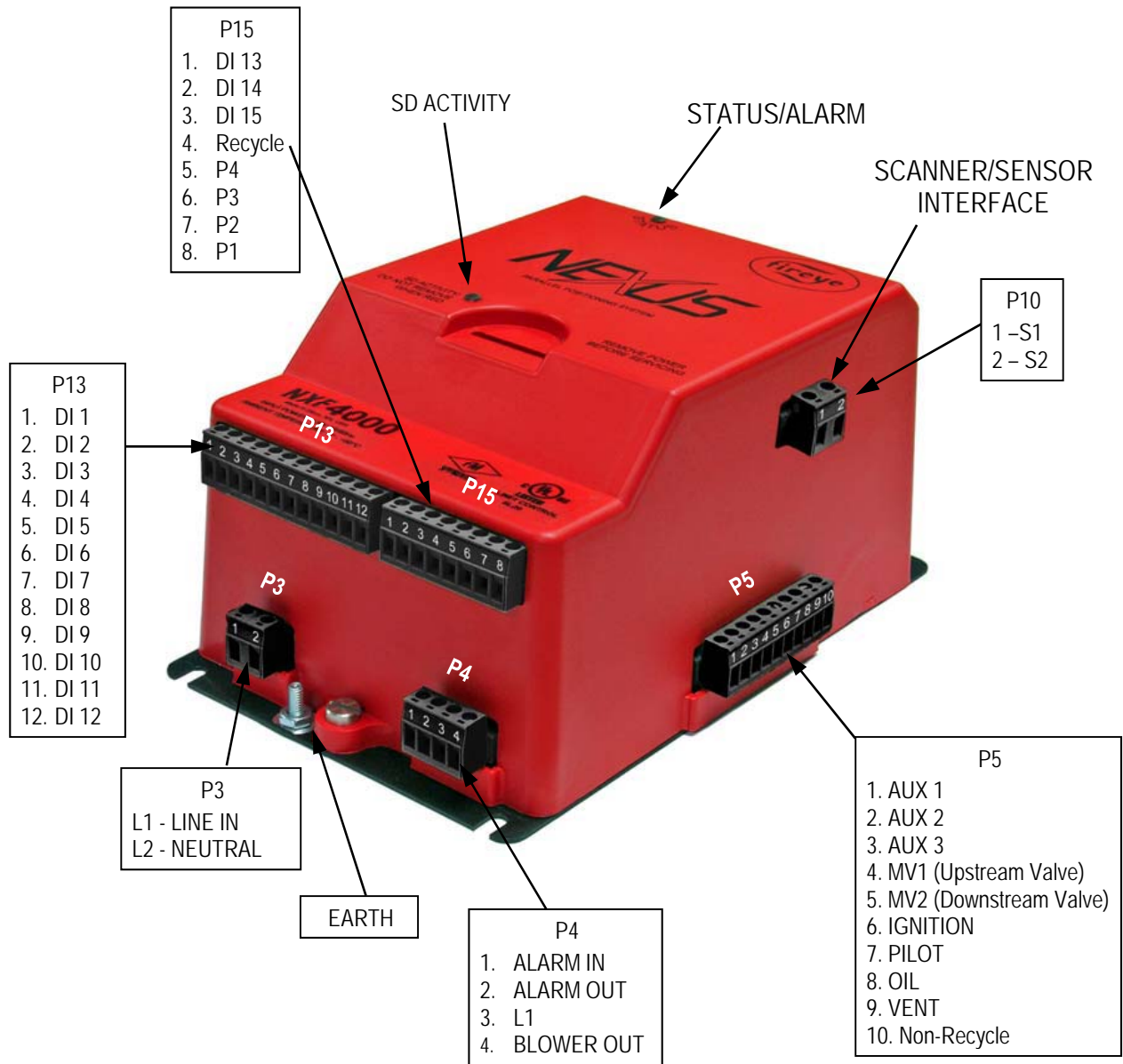

WARNING: If Valve Proving is not used, the main fuel gas valves must be connected to terminal P5-5 (MV2). Terminal P5-4 (MV1) is energized during PTFI to accommodate installations where pilot valve is installed between upstream and downstream main fuel valves.

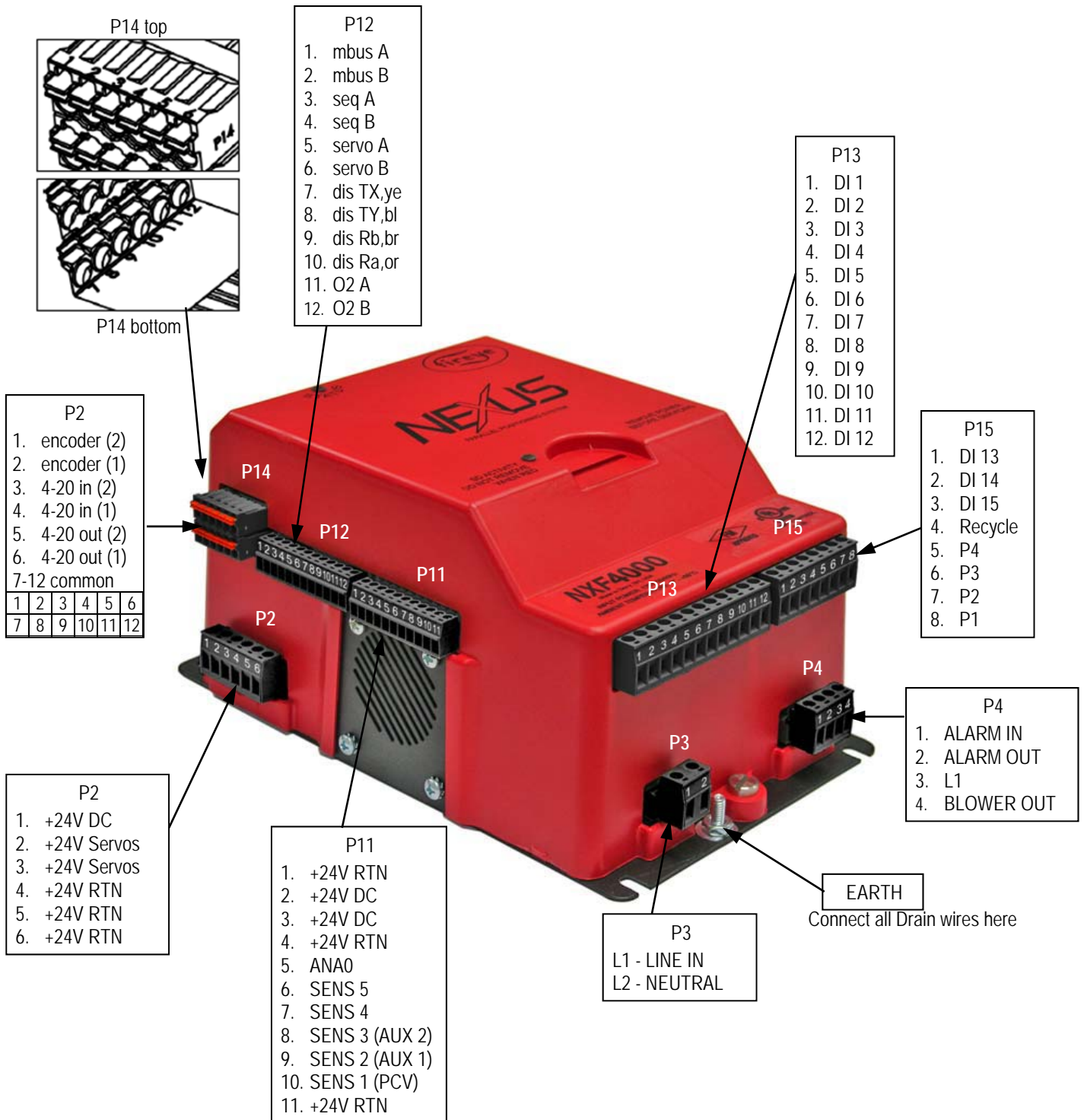

Table 1: LOAD RATINGS

Terminal	Typical Load	Ratings
P4.4	Burner/Blower Motor	575VA (P.F. = 0.7)
P5.4	MV1 (Upstream valve)	575VA (P.F. = 0.7)
P5.5	MV2 (Downstream valve)	575VA (P.F. = 0.7)
P5.6	Ignition Transformer	575VA (P.F. = 0.7)
P5.7	Pilot Valve	575VA (P.F. = 0.7)
P5.8	Oil Valve	575VA (P.F. = 0.7)
P5.9	Vent Valve/Solenoid	575VA (P.F. = 0.7)

NOTICE: Maximum connected load must not exceed 2000 VA

ELECTRICAL RATINGS

VA ratings (not specified as pilot duty) permit the connection of transformers and similar devices whose inrush current is approximately the same as their running current.

VA Pilot Duty ratings permit the connection of relays, solenoid valves, lamps, etc. whose total operating load does not exceed the published rating and whose total inrush current does not exceed 10 times the rating.

Running and locked rotor ratings are intended for motors. VA and VA Pilot Duty loads may be added to a motor load provided the total load does not exceed the published rating.



CAUTION: Published load ratings assume that no contact will be required to handle inrush current more often than once in 15 seconds. Using control switches, solenoid, relays, etc. which chatter lead to premature failure. Run through a test operation (with fuel shut off) following the tripping of a circuit breaker, a blown fuse, or any known instance of chattering of any external current consuming devices.

WIRING CONNECTIONS

Terminal	Type	Description	Rating/wiring
P3.1	L1	Line Voltage Supply	120 VAC (+10%, -15%) 50/60 Hz 230 VAC (+10%, -15%) 50/60 Hz
P3.2	L2/N	Line Voltage Common	
EARTH (stud)		Protective Earth	Chassis ground connection
P4.1	Input	Alarm Relay Input	Voltage free contacts
P4.2	Output	Alarm Relay Output	Voltage free contacts, Connect to alarm bell or indicator. 240VA load
P4.3	Input	L1 (Mains)	Line Input
P4.4	Output	Blower Output	Connect to Blower or motor starter See loading table
P2.1	Power	O2 Probe & User Interface Power	24 VDC, 59-562 - RED
P2.2	Power	Servo Power, uC controlled	24 VDC, 59-565 - RED
P2.3	Power	Servo Power, uC controlled	24 VDC, 59-565 - RED
P2.4	Common	O2, User Interface, Servo VDC Return	0 VDC, 59-562 - BLACK
P2.5	Common	O2, User Interface, Servo VDC Return	0 VDC, 59-565 - BLACK
P2.6	Common	O2, User Interface, Servo VDC Return	0 VDC, 59-565 - BLACK
P11.1	Common	0 VDC	VDC Return
P11.2	Power	Temp/Pressure Source Voltage	24 VDC Nominal (class 2)
P11.3	Power	Temp/Pressure Source Voltage	24 VDC Nominal (class 2)
P11.4	Common	0 VDC	VDC Return
P11.5	Output	Analog Output	4-20mA output
P11.6	Input	SENS 5 Sensor Analog Input	See Table 2 for sensor type, range and settings
P11.7	Input	SENS 4 Sensor Analog Input	
P11.8	Input	SENS 3 (AUX2) Sensor Analog Input	
P11.9	Input	SENS 2 (AUX1) Sensor Analog Input	
P11.10	Input	SENS 1 (PCV) Sensor Analog Input	
P11.11	Common	0 VDC	VDC Return
P12.1		Modbus-RTU A	Touchscreen & BAS access
P12.2		Modbus-RTU B	Touchscreen & BAS access
P12.3		SEQUENCING A	Connect to other NXF4000, if needed
P12.4		SEQUENCING B	Connect to other NXF4000, if needed
P12.5		Servo Comms A1	59-565, ORANGE
P12.6		Servo Comms B1	59-565, BROWN
P12.7		User Interface, Tx	59-562, YELLOW
P12.8		User Interface, Ty	59-562, BLUE
P12.9		User Interface, Rb	59-562, BROWN
P12.10		User Interface, Ra	59-562, ORANGE
P12.11		O2 Comms A1	59-565, ORANGE
P12.12		O2 Comms B1	59-565, BROWN



Terminal	Type	Description	Rating/wiring
P13.1	D1 1	Digital Input #1	120/230 VAC @ 1mA
P13.2	D1 2	Digital Input #2	120/230 VAC @ 1mA
P13.3	D1 3	Digital Input #3	120/230 VAC @ 1mA
P13.4	D1 4	Digital Input #4	120/230 VAC @ 1mA
P13.5	D1 5	Digital Input #5	120/230 VAC @ 1mA
P13.6	D1 6	Digital Input #6	120/230 VAC @ 1mA
P13.7	D1 7	Digital Input #7	120/230 VAC @ 1mA
P13.8	D1 8	Digital Input #8	120/230 VAC @ 1mA
P13.9	D1 9	Digital Input #9	120/230 VAC @ 1mA
P13.10	D1 10	Digital Input #10	120/230 VAC @ 1mA
P13.11	D1 11	Digital Input #11	120/230 VAC @ 1mA
P13.12	D1 12	Digital Input #12	120/230 VAC @ 1mA
P15.1	D1 13	Digital Input #13	120/230 VAC @ 1mA
P15.2	D1 14	Digital Input #14	120/230 VAC @ 1mA
P15.3	D1 15	Digital Input #15	120/230 VAC @ 1mA
P15.4	Input	Recycle Limit / Operating control	120/230 VAC @ 1mA
P15.5	Input	P4, Profile 4 Select	120/230 VAC @ 1mA
P15.6	Input	P3, Profile 3 Select	120/230 VAC @ 1mA
P15.7	Input	P2, Profile 2 Select	120/230 VAC @ 1mA
P15.8	Input	P1, Profile 1 Select	120/230 VAC @ 1mA
P5.1	Output	Programmable relay 1	120/230 VAC, 480VA
P5.2	Output	Programmable relay 2	120/230 VAC, 480VA
P5.3	Output	Programmable relay 3	120/230 VAC, 480VA
P5.4	Output	MV1 - Upstream Gas Valve	See loading table
P5.5	Output	MV2 - Downstream Gas Valve	See loading table
P5.6	Output	Ignition terminal	See loading table
P5.7	Output	Pilot valve terminal	See loading table
P5.8	Output	Oil valve terminal	See loading table
P5.9	Output	Vent valve terminal (Auxiliary)	See loading table
P5.10	Output	(P) Non-recycle input	Connect to non-recycle limits - 16A @ 120V max 8A @ 230V max
P14.1	Input	Encoder Input (2)	Encoder feedback
P14.2	Input	Encoder Input (1)	Encoder feedback
P14.3	Input	4-20 mA IN (2)	VFD (2) feedback
P14.4	Input	4-20 mA IN (1)	VFD (1) feedback
P14.5	Output	4-20 mA OUT (2)	VFD (2) drive
P14.6	Output	4-20 mA OUT (1)	VFD (1) drive
P14.7 - P14.12		Common	Signal return



Terminal	Type	Description	Rating/wiring
P10.1	Input	S1	UV/IR/DC scanner connection
P10.2	Input	S1	

Caution: If Valve Proving is not used, the main fuel gas valves must be connected to terminal P5-5 (MV2).



CAUTION: Ensure that electric power is turned off. Refer to SN-100 for recommended grounding techniques. Be aware that power to some interlocks (operating controls, air flow switches, modulating circuits, etc.) may be derived from sources other than what is controlling the NXF4000.

NXF4000 MOUNTING AND WIRING

As a convenience, the NXF4000 is equipped with de-pluggable type terminal blocks. It is recommended the NXF4000 be wired with the terminal blocks inserted into the control as shipped.

Following the wiring connections table above, make all electrical connections in accordance with the application requirements. The suggested order of wiring is as follows:

1. Power inputs, L1, L2, Earth (AWG 18, 300/600 VAC) P3.1, P3.2
2. NXD410 user interface using Fireye cable 59-562-2 P12.7-P12.10; P2.1, P2.4
3. Servo motors P2.2, P2.3, P2.5, P2.6, P12.5, P12.6, P12.11, P12.12
4. Alarm relay contacts if required (AWG 16-18, 300/600 VAC)
5. Digital inputs (AWG 14-16, 300/600 VAC) P13.1 - P13.12, P15.1-P15.3
6. Recycle limit interlock input P15.4
7. Non-Recycle limit interlock input P5.10
8. Ignition, Pilot, Oil & Gas Valves P5.4-P5.8
9. Profile select inputs (AWG 18, 300/600 VAC) P15.5-P15.8
10. Blower input P4.3
11. Pressure / Temperature sensors (shielded cable, Belden 9318) P11.1-P11.11
12. Flame Scanner interface P10.1 - P10.2

PRESSURE AND TEMPERATURE SENSORS

1. Insure that the range of the selected pressure or temperature sensor is appropriate for the application. See Table 2.

Note: A general rule to follow when selecting the sensor range is that the expected value of the monitored pressure or sensor should fall between 35-75% of the upper range of the sensor. For example, a steam boiler maintains 15 lbs. pressure, select the BLPS-30 Pressure Sensor, with a 0-30 PSI range.

2. The sensors must be located where the ambient temperature will not exceed the maximum ambient operating temperature specified for the sensor. Insure that the pressure range programmed on the NXF4000 Control matches the installed pressure sensor.
3. Vacuum return systems will occasionally pull a positive pressure sensor into a vacuum condition which will cause a "sensor out of range" fault, requiring a manual reset. The BLPS-25's range is -14.7 to 25 PSI and will operate normally should the system go to vacuum. Please note however, the available set point range is 1.0 PSI to 23.0 PSI in 0.1 PSI increments.
4. Do not mount any of the sensors where they could be used as a footstep.

Installation must be performed by a trained, experienced flame safeguard technician.



Table 1: SENSOR RANGE and SETTINGS

Part Number	Sensor Type	Set Point Range	Cut In	Cut Out	Mod Range	Increment Decrement
BLPS-15	0 - 15 PSI	1.0 - 14.0p	0 - 6.0p	0.3 - 6.0p	0.3 - 6.0p	0.1p
	0 - 1030m	70m - 950m	0 - 410m	20m - 410m	20m - 410m	10m
BLPS-25	-14.7 - 25 PSI	1.0 - 23.0p	0 - 6.0p	0.3 - 6.0p	0.3 - 6.0p	0.1p
	-1013 - 1720m	70m - 1500m	0 - 410m	20m - 410m	20m - 410m	10m
BLPS-30	0 - 30 PSI	1.0 - 28.0p	0 - 6.0p	0.3 - 6.0p	0.3 - 6.0p	0.1p
	0 - 2070m	70m - 1950m	0 - 410m	20m - 410m	20m - 410m	10m
BLPS-200	0 - 200 PSI	10 - 190p	0 - 60p	3 - 60p	3 - 60p	0.1p
	0 - 13.8B	0.70 - 13.0B	0.0 - 4.1B	0.2 - 4.10B	0.20 - 4.10B	.05B
BLPS-300	0 - 300 PSI	10 - 280p	0 - 60p	3 - 60p	3 - 60p	0.1p
	0 - 20.7B	0.70 - 19.3B	0.0 - 4.1B	0.2B - 4.10B	0.2B - 4.10B	.05B
Note: 1 PSI = 68.94757 mbar						
TS350-X*	32° - 350°F	35° - 338°F	0° - 60°F	3° - 60°F	3° - 60°F	1°F
	0° - 176°C	4° - 170°C	0° - 60°C	3° - 60°C	3° - 60°C	1°C
TS752-X*	32° - 752°F	35° - 725°F	0° - 60°F	3° - 60°F	3° - 60°F	1°F
	0° - 400°C	4° - 385°C	0° - 60°C	3° - 60°C	3° - 60°C	1°C
m = millibar, p = psi, B= BAR						

*Select Length X = -2", -4" or -8"

MOUNTING PRESSURE SENSORS

1. The steam pressure sensors (BLPS-15, -25, -30, -200, -300) provide a 1/4" NPT female fitting for connection to the steam header.
2. Make sure the boiler is shut down and zero steam pressure exists in the boiler vessel.
3. Disconnect power to the boiler controller so the boiler cannot sequence during installation of the steam pressure sensor.
4. Always mount the steam pressure sensor above the water line of the boiler.
5. Locate the pressure sensors where the ambient temperature will not exceed 185F (85C).
6. Use only a small amount of pipe compound to seal the connection joints. Excess pipe compound may clog the fitting and prevent proper operation of the sensor.
7. Although the unit can withstand substantial vibration without damage or significant output effects, it is good practice to mount the pressure sensor where there is minimum vibration.
8. A steam trap (siphon loop) must be connected between the boiler and the pressure sensor to prevent boiler scale and corrosive vapors from affecting the pressure sensor element.
9. Make all pipe connections in accordance with approved standards.
10. When tightening the sensor, apply a wrench to the hex flats located just above the pressure fitting. DO NOT tighten by using a pipe wrench on the housing. Do not tighten the pressure sensor by hand.



WARNING: The electro-mechanical high steam limit and/or high hot water temperature limit MUST REMAIN in the running interlock circuit.

MOUNTING TEMPERATURE SENSORS

The immersion style temperature sensors have a ½” NPT mounting for the 2”, 4”, and 8” thermowell probes, and a ½” conduit fitting for electrical connections.



WARNING: Location of the temperature sensor to monitor boiler water temperature of a steam boiler is critical. The sensor should be mounted where it is always exposed to the circulation of the boiler water, not too close to a hot or cold inlet or steam coil. Consult the boiler manufacturer for guidance for its location or refer to Bulletin BLZPTS-1 for proper location and wiring of this temperature sensor.

WIRING PRESSURE AND TEMPERATURE SENSORS



CAUTION: Disconnect power supply from the NXF4000 Control before connecting wires to prevent electrical shock and equipment damage.

1. All wiring must be in accordance with National Electrical Code and local codes, ordinances, and regulations.
2. Sensor housing provides connection for 1/2” conduit.
3. The pressure and temperature sensors require 2 conductor, 18 gauge, shielded cable. Power limited, rated for 300V @105C. Use Belden 9318 or equivalent. The shield should be connected to the earth ground terminal on the base of the NXF4000 Control. The shield should be taped at the sensor to avoid unintended contact with the sensor housing.
4. All sensor wiring should be in a separate conduit. DO NOT install sensor wiring in any conduit or junction boxes with high voltage wiring.
5. Maximum wiring distance for sensor wiring is 100 feet.

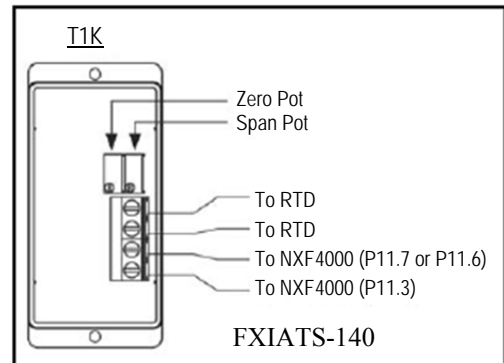
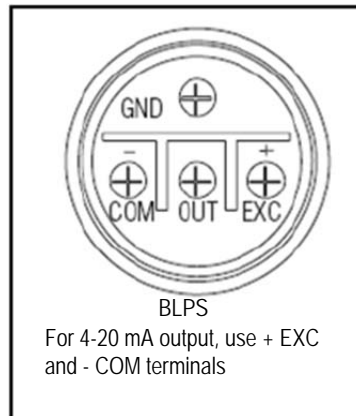
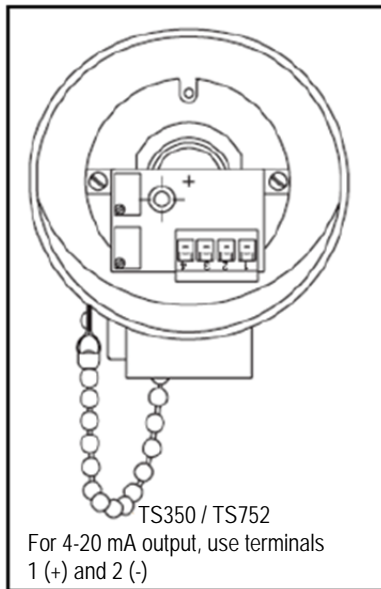

TS350/TS752	BLPS	SENS1	SENS2	SENS3	SENS4	SENS5
1+	+EXC	P11.2	P11.2	P11.3	-	-
2-	-COM	P11.10	P11.9	P11.8	-	-
FXIATS-140						
1+	-	-	-	P11.3	P11.3	P11.3
2-	-	-	-	P11.8	P11.7	P11.6

FLAME SCANNERS

FIGURE 1. FLAME SCANNERS



CAUTION: The UV1AL, UV5 and UV90L flame scanners are non-self checking UV systems and must only be applied to burners that often cycle (e.g.: a minimum of once per 24 hours) in order for the safety checking circuit to be exercised. If component checking is required during burner operation for constantly fired burners, use infrared flame scanner (48PT2) with associated Auto Check amplifier (NXCESIR), or integrated scanners (Phoenix, InSight II or InSight) with associated amplifier (NXCESDC).

INSTALLATION - UV SCANNERS

Where possible, obtain the burner manufacturer's instructions for mounting the scanner. This information is available for most standard burners. The scanner mounting must comply with the following general instructions:

1. Position the UV1AL scanner within 30 inches of the flame to be monitored.
2. Select a scanner location that remains within the ambient temperature limits of the UV Scanner. If cooling is required, use an insulating coupling (Fireye #35-69 for UV1AL Scanners) to reduce conducted heat.
3. The UV1AL Scanners are designed to seal off the sight pipe up to 1 PSI pressure. Higher furnace pressures should be sealed off. To seal off positive furnace pressure up to 100 PSI for UV1AL Scanners, install a quartz window coupling (#60-1257). Add cooling air to reduce the scanner sight pipe temperature.
4. Install the scanner on a standard NPT pipe (UV1AL: 1/2", UV5: 1/2") whose position is rigidly fixed. If the scanner mounting pipe sights through the refractory, do not extend it more than halfway through. Swivel flanges are available if desired (#60-302 for UV1AL Scanners). The sight pipe must permit an unobstructed view of the pilot and/or main flame, and both pilot and main flames must completely cover the scanner field of view

FIGURE 2. AIMING YOUR SCANNER

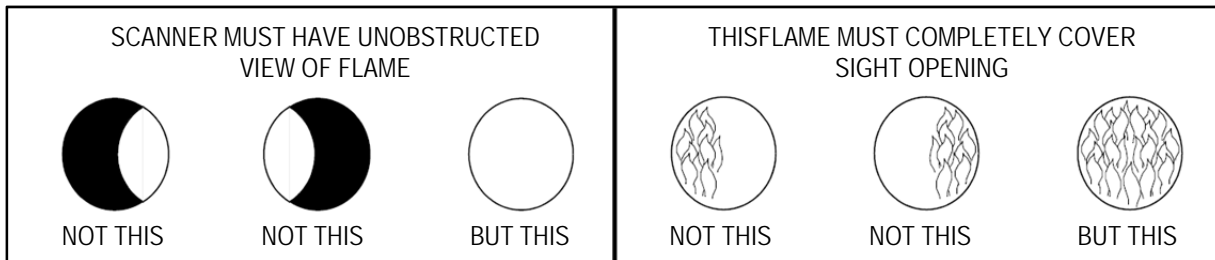

5. Smoke or unburned combustion gases absorb ultra-violet energy. On installations with negative pressure combustion chambers, a small hole drilled in the UV1AL sight pipe will assist in keeping the pipe clean

and free from smoke. Provide clean air to pressurize the sight pipe, if necessary for positive pressure furnaces.

6. Two UV1AL Scanners may be installed on the same burner if it is necessary to view two areas to obtain reliable detection of the flame. They are wired in parallel. Only one repetitive self-checking 35UV5 Scanner can be installed on a burner.
7. To increase scanner sensitivity with UV1AL Scanners, a quartz lens permits location of the scanner at twice the normal distance. Use 1/2" x 1 1/2" pipe nipple between UV1A Scanner and the coupling.
8. Request the assistance of any Fireye field office for recommendations of a proper scanner installation on a non-standard application.

FIGURE 3. TYPICAL SCANNER INSTALLATIONS

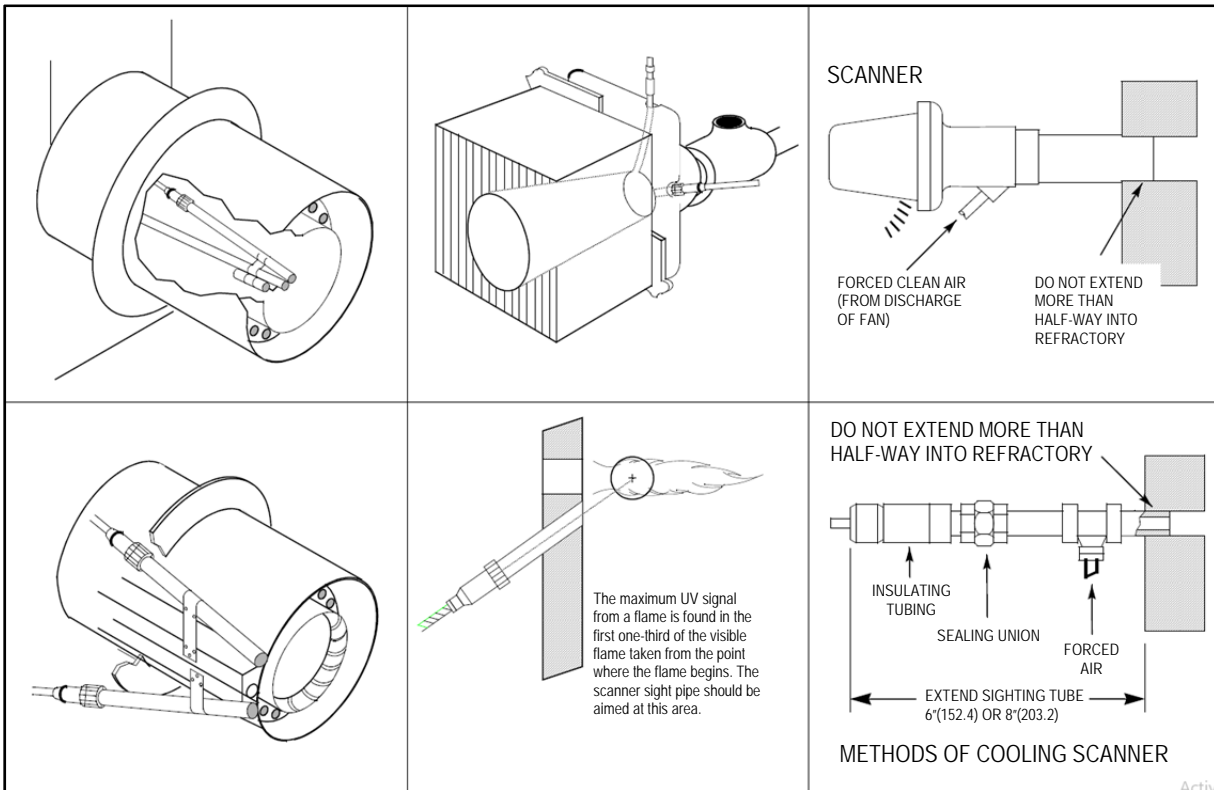

WIRING - UV SCANNERS

To connect the scanner to the control, the UV1AL Scanner is supplied with either 36"(.9m) or 72" (1.8m) of flexible cable. The UV5-1 scanner is supplied with 78" (2m) of flexible cable. The 35UV5 is supplied with four 72" (1.8m) lead wires. Install them in a suitable length of flexible armor cable and connect it to the control. A conduit connector is supplied with the scanner. Connect black wires (shutter) to terminals L1, L2; red wires (UV tube) to terminals S1, S2.

If it is necessary to extend the scanner wiring, the following instructions apply:

Scanner wires should be installed in a separate conduit. The wires from several scanners may be installed in a common conduit.

1. Selection of Wire
 - a. Wiring: For extended scanner wiring up to 500 feet, and for shorter lengths to reduce signal loss, use a shielded wire (Belden 8254-RG62 coaxial cable, or equal) for each scanner wire of UV1AL and each red wire of the 35UV5. The ends of the shielding must be taped and not grounded.
 - b. Asbestos insulated wire must be avoided.
 - c. Multi-conductor cable is not recommended without prior factory approval.

- High voltage ignition wiring must not be installed in the same conduit with flame detector wires.

INSTALLATION—INFRARED SCANNER TYPE 48PT2

Where possible, obtain the burner manufacturer's instructions for mounting the scanner, otherwise proceed as follows:

A single scanner is used to detect both pilot and main flames. The sight pipe on which the scanner mounts must be aimed so that the scanner sights a point at the intersection of main and pilot flames.

Proper scanner positioning must assure the following:

- Reliable pilot flame signal.
- Reliable main flame signal.
- A pilot flame too short or in the wrong position to ignite the main flame reliably, must not be detected.
- Scanner must have an unobstructed view of flame being monitored.
- Flame being monitored must completely cover the scanner field of view.
- To avoid nuisance shutdowns, it is important to avoid sighting hot refractory and to keep scanner temperature below 140° F (60°C).
- When the proper position has been established, drill a hole through the furnace wall and install a 4" to 8" (101.6mm x 203.2mm) length of threaded 1/2" black iron pipe on which to mount the 48PT2 scanner.
- When satisfactory sighting position has been confirmed by operating tests, the sight tube should be firmly welded in place.

FIGURE 4. SCANNER INSTALLATIONS

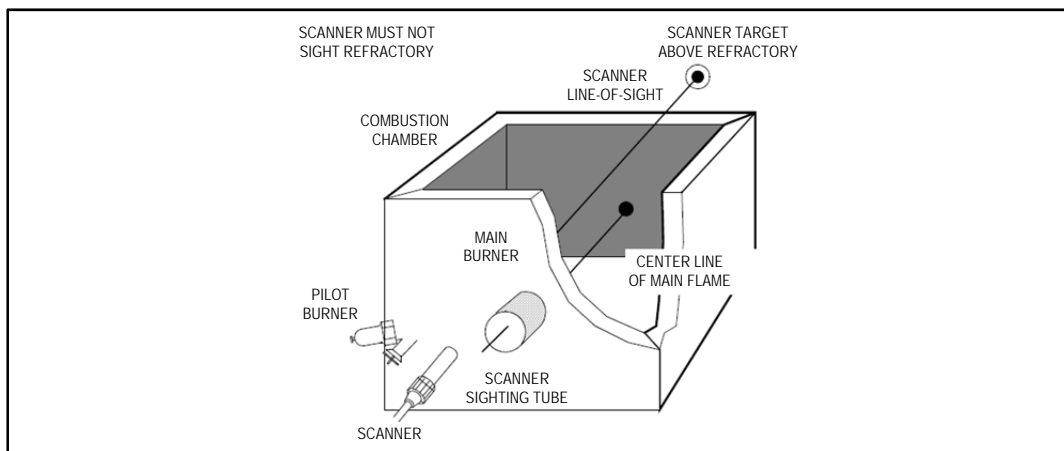

WIRING

Attach the cable supplied with the scanner to a junction box. Splice the cable wires to a pair of wires not smaller than #18. Install the complete run in a separate conduit to the control. Continuous conduit bonding between scanner and the control is mandatory! Scanner may be located up to 100 feet from control. Do not pass scanner wiring through any junction box containing other wires. Do not run other wires through scanner conduit. Asbestos insulated wire must be avoided.

- To avoid nuisance shutdowns, avoid sighting hot refractory and to keep your scanner temperature low below 140° F (60°C).
- When the proper position has been established, drill a hole through the furnace wall and install a 4" to 8" (101.6mm x 203.2mm) length of threaded 1/2" black iron pipe on which to mount the 48PT2 scanner.
- When satisfactory sighting position has been confirmed by operating tests, the sight tube must be firmly welded in place.

INSTALLATION - 85 SERIES PHOENIX SCANNER

Fireye Phoenix 85UVF self-checking scanners are used to detect 295 to 340 nanometers wavelength ultraviolet emissions.

Fireye Phoenix 85IRF self-checking scanners are used to detect 830 to 1100 nanometers wavelength infrared emissions.

Fireye Phoenix scanners are suited for application to duct burners, industrial gas/oil burners, refinery applications, ignition systems and Low NOx detection and for continuous or non-continuous burner operation.

NOTE: Because the sensors in the Phoenix are solid state devices they can perform well with many different fuels. For example UV is typically used on gaseous fuels but can also be applied to oils and heavy oils. To be 100% sure of correct application a test should be performed. Phoenix scanners ARE NOT recommended for use on small pilot flames or obstructed sighting.

Operator interface to the Phoenix scanner is via a push-button keypad and informative LEDs. These provide continuous indication of flame signal, flame relay status, scanner status as well as selected mode of operation. Simplified keystroke routines are used for setup and this can be completed in seconds. For remote interface, outputs are provided for flame switch, fault relay and 4 to 20mA flame strength.

The installer must assure the combined flame failure response (FFRT) time of the Phoenix and BurnerLogix is within the guidelines of the local codes. Refer to bulletin CU-114 for detailed information.

FIGURE 5. PHOENIX WIRING DIAGRAM

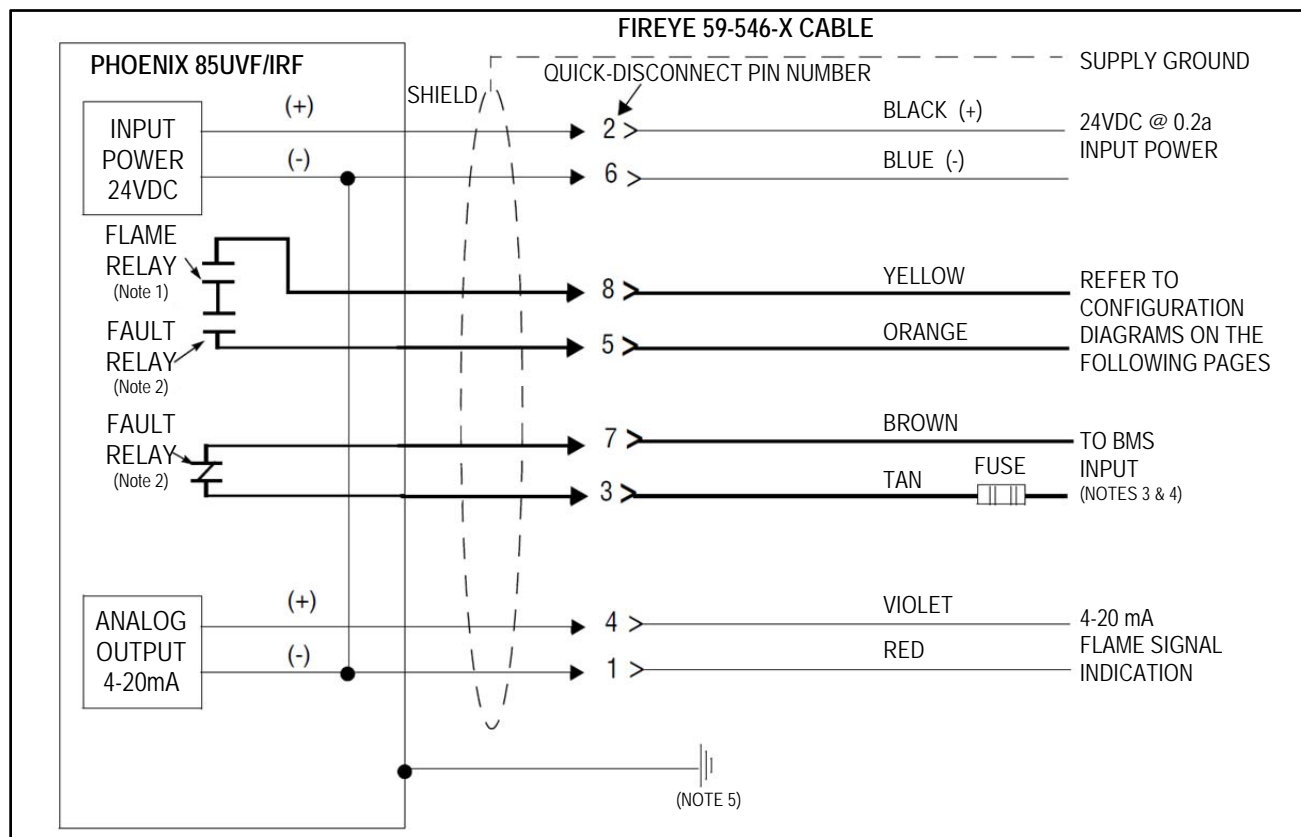

Notes:

1. Flame relay contacts are shown in the de-energized (no flame condition).
2. Fault relay contacts are shown in de-energized (fault) condition.
3. BMS = Burner Management System (by others). Do not use Red as 24 volt ground.

4. External 2.0 Amp fuses recommended.
5. A safety ground screw is provided on the scanner end plate. An external ground wire must be installed if line voltage is applied to the relay contacts.

Table 2. PHOENIX SCANNER CABLE COLOR CODE

NEW 59-546 CABLE COLOR CODE (Connector Pin No.)	FUNCTION	OLD 59-497 CAPTIVE-CABLE COLOR CODE <i>For reference only</i>
(2) Black	24 vdc Input (+)	Black / Red
(6) Blue	24 vdc Input (-)	White / Blue
(8) Yellow	Flame Relay Contact (n.o.)	White / Red
(5) Orange	Flame Relay Contact (n.o.)	White / Black
(7) Brown	Fault Relay Contact (n.c.)	Red
(3) Tan	Fault Relay Contact (n.c.)	Pink
(4) Violet	4-20 ma Analog Output (+)	Violet
(1) Red	4-20 ma Analog Output (-)	Grey / Red
Shield Drain Wire	Earth Ground	Shield Drain Wire

FIGURE 6. NXF4000 w/NXCESDC card WITH 85UVF4-1QDWR SCANNER

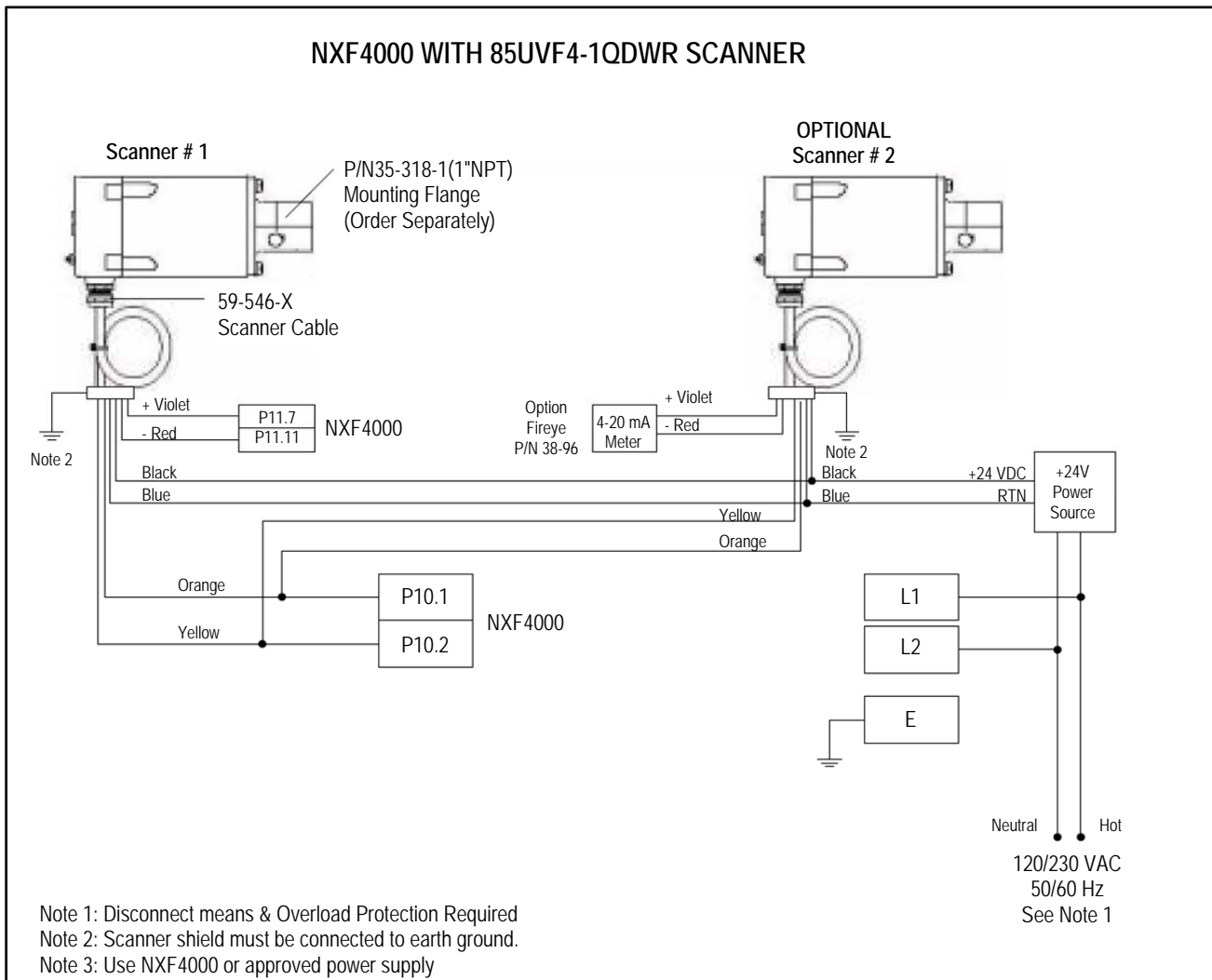



INSTALLATION - 95 SERIES INSIGHT SCANNERS

Type 95IR contains an infrared flame sensor, responding to infrared radiation from 700 to 1700 nanometers wavelength. This sensor is best suited to coal and oil applications.

Type 95UV contains an ultraviolet flame sensor, responding to ultraviolet radiation from 295 to 320 nanometers wavelength. This sensor is best suited to gas applications.

Type 95DS (Dual sensor) contains both the infrared and ultraviolet flame sensors described above. This sensor is best suited to multi-fuel applications.

The InSight scanners measure the amplitude of the modulations (the flame “flicker”) that occur within the targeted flame. During the scanner set-up procedure, the modulation frequency that yields the best flame ON/OFF discrimination is selected. The appropriate modulation frequency and sensor gain is either manually selected (S1 models), or automatically selected with manual override capability (S2 models).

The InSight 95IR, 95UV, and 95DS scanners are each available in two models differentiated by feature levels.

The Base Model S1 (Europe only) has three choices of modulation frequency, adjustable sensor gain, adjustable flame relay ON/OFF thresholds, 4-20 mA analog signal strength output, fault relay, and two selectable programmable files to store setpoints (for two different fuels or firing rates).

The Expanded Model S2 adds automatic programming (AutoTune) with manual override capability, 21 choices of flame flicker frequency, a total of four selectable programmable files to store setpoints, plus adds remote communication capability via Fireye Windows 95/98/NT user software.

All FIREYE InSight scanner models are powered by 24 Vdc and contain electronic self-checking (no mechanical shutter required). The scanners contain an eight character alpha-numeric LED display and a four (4) push-button keypad to enable the user to view operating parameters and select setpoints.

The Base Model S1 is best suited to the many applications that do not require the level of sophistication, or the remote communications capability of the Expanded Model S2 (e.g. single burner boilers and furnaces, duct burners, etc.)

The Expanded Model S2 is best suited to the applications that require the highest level of sophistication and flexibility (additional choices of modulation frequencies, and the time-saving AutoTune function), and remote communications capability (e.g. larger multi-burner boilers and furnaces).

Because of the shorted cable detect algorithm built into the NXF4000, it is imperative the proper cable be used when employing InSight scanners.

FIGURE 7. INSIGHT WIRING DIAGRAM

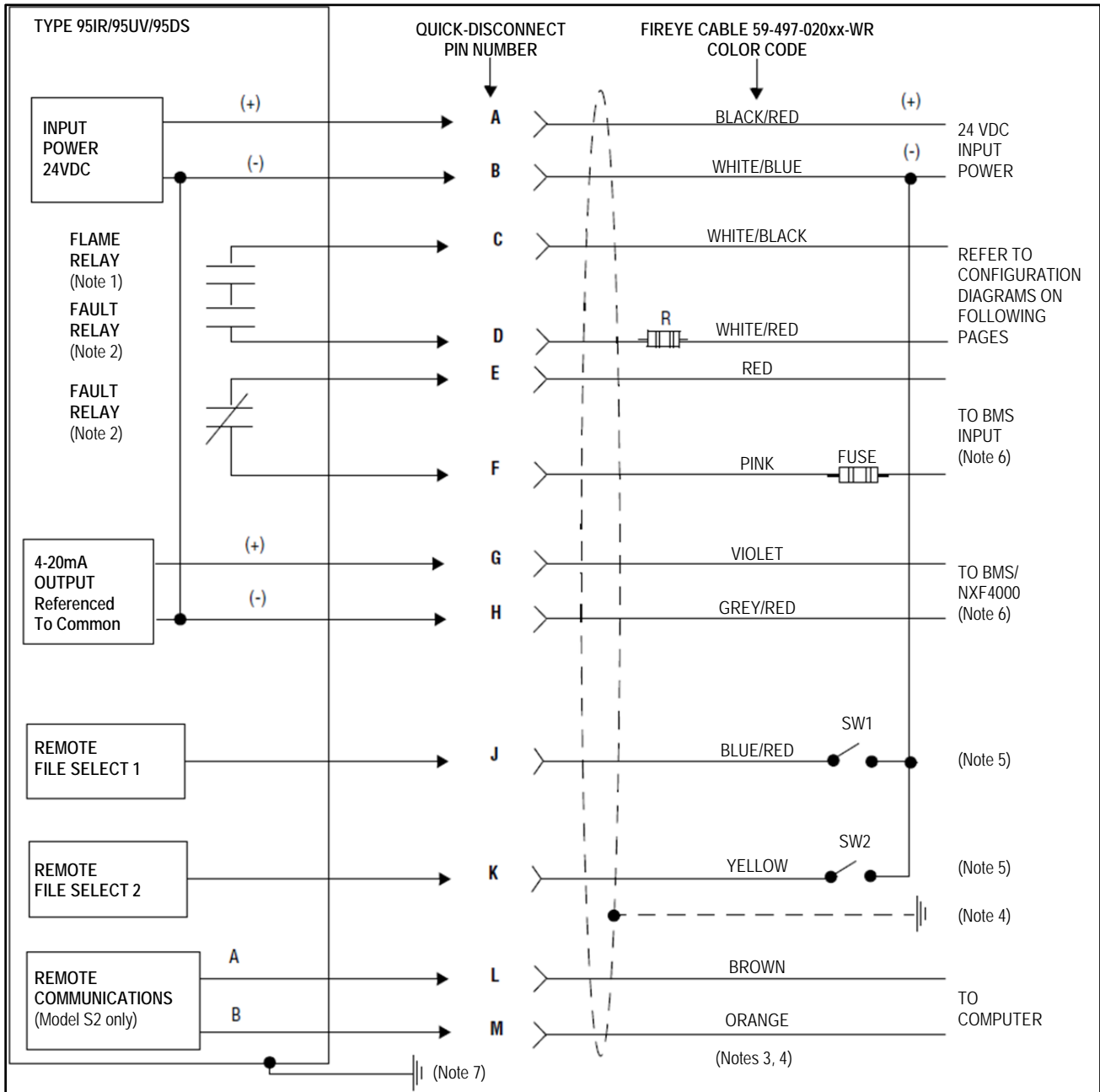

Notes:

1. Flame relay contacts are shown in de-energized (no flame) condition.
2. Fault relay contacts are shown in de-energized (fault) condition.
3. Brown and orange wires are a twisted pair.
4. Connect cable shield to earth ground at the power source.
5. With Remote File Select programmed as "LINE", external switches SW1/SW2 (not furnished) select between two (S1 Models) or four (S2 Models) internal memory files, when connected to 24Vdc (-) supply.
6. External 2.0 Amp fuses recommended.
7. A ground screw is provided on the scanner end plate. An external ground wire must be installed if line voltage is applied to the relay contacts.

FIGURE 8. NXF4000 with INSIGHT ISCANNER

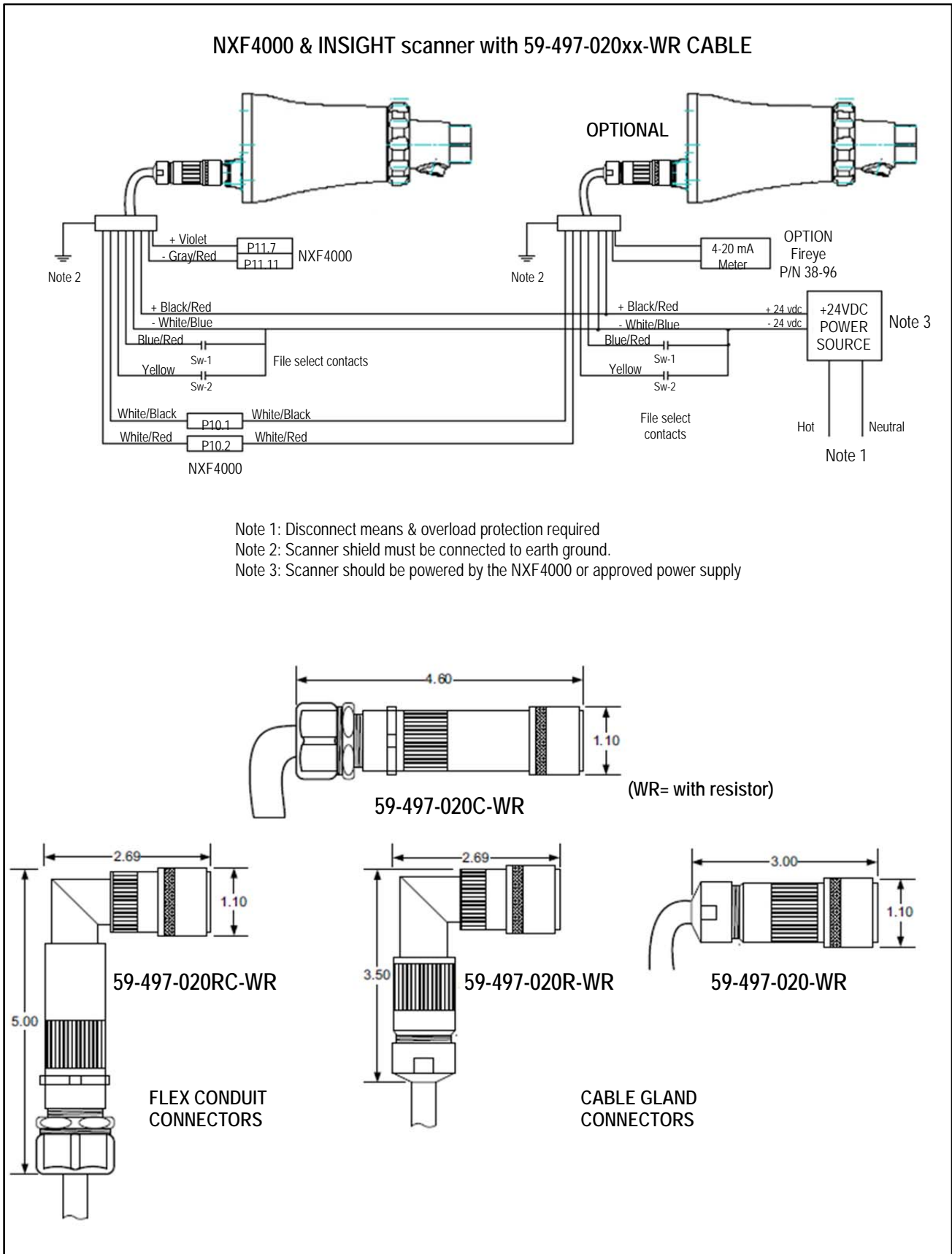

SERVO MOTOR SETUP AND WIRING

The NXF4000 must have a “master servo” in order to generate a valid modulation curve. In a typical setup, without VFD, the AIR servo is automatically selected as the master servo; if a VFD is used, the first fuel servo is automatically selected as the master servo. The NXF4000 will support **single servo** installation, provided that the single servo is a fuel servo and the VFD controls the air. The modulation rate, low fire to high fire, and therefore the servo(s) positions are derived from the master servo commissioning values. Each servo is equipped with an internal rotary switch that is used to select its communication address. The address range is 1 to 10. It does not matter what each servo address is but it is required that each servo have its own **unique** address.

NOTICE: The servo addresses are learned during power on. Hence, if a servo address changes mode, it is advised to power cycle the system for the new address to be effective.

It is recommended that servos be wired to the NXF4000 in a multi-drop configuration. That is, cabling traverses from the control to the first servo, to the second servo, to the third servo, etc. Servo types FX04-1, FX20-1 and FX50-1 are pre-wired to connectors located on the body of the servo. Cordsets having female connectors on both ends are available in 6 and 40 foot lengths. Field wireable connectors and cable are also available. See ORDERING INFORMATION for part numbers. Servo types FX04, FX20 and FX50 allow the installation of conduit fittings and the user to wire directly to the servos using the terminal strips located inside the servo. Always connect the ground first to eliminate any ESD (electro-static discharge) potential.

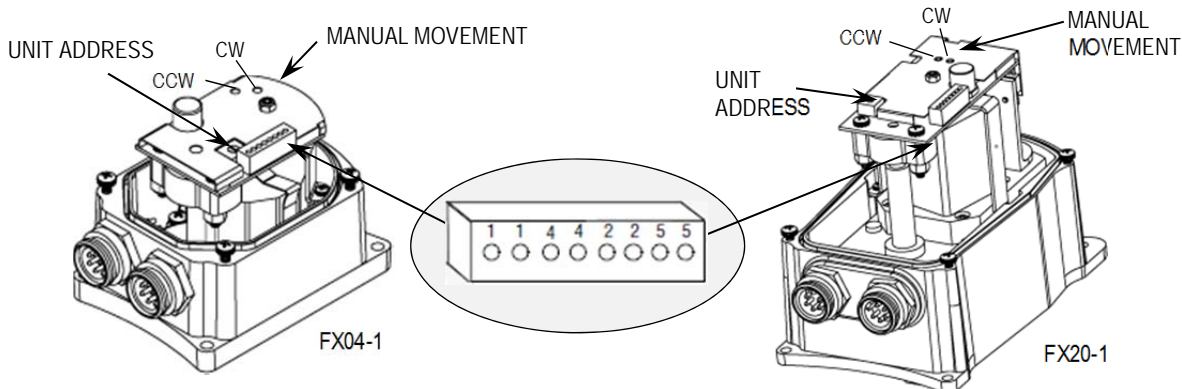

WARNING: DO NOT USE THE MANUAL MOVEMENT SWITCHES ON THE SERVO MOTORS DURING AUTOMATIC OPERATION OR THE FIRING CYCLE OF THE BURNER. USE OF THE MANUAL MOVEMENT SWITCHES OPERATES THE SERVOMOTORS INDEPENDENT OF THE NXF4000 CONTROL COULD RESULT IN AN OFF-RATIO CONDITION IF OPERATED DURING AUTOMATIC OPERATION OR THE FIRING CYCLE

Servo Wiring Diagram, internal

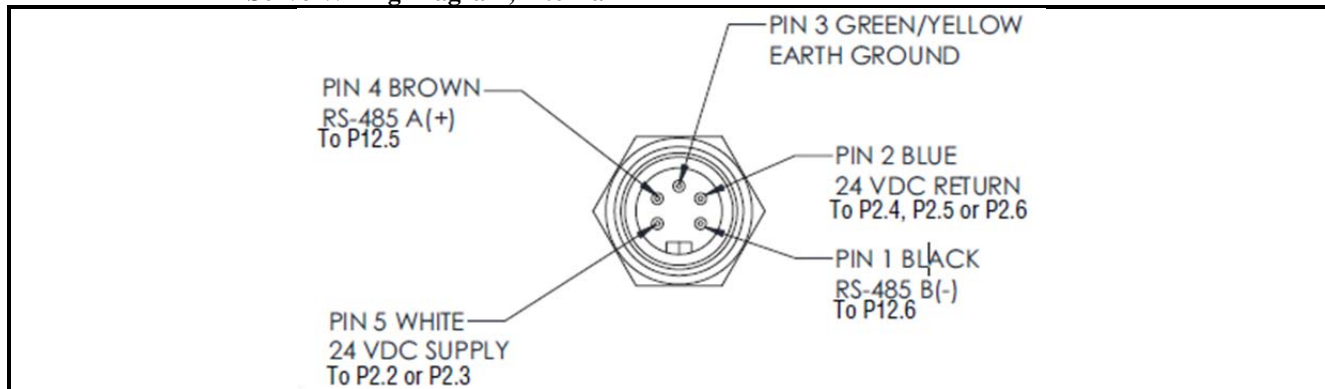

Refer to bulletins NEX-3004, NEX-3020 and NEX-3050 for operational details, setting the addresses and servo movement.

The NXF4000 provides two terminals for 24 Vdc supply for the servos P2.2 & P2.3 (24 Vdc return via P2.4-P2.6). The NXF4000 can supply approximately 60 VA through these terminals for any combination of connected servos. The NXF4000 can supply up to ten 4Nm servos or four 20Nm servos, or three 50Nm servos or some combination that will result in 60 VA of power². If more power than this is required, an external power supply must be used³. See figure 5 for recommended wiring of the external power supply.

1. Power budget for the NXD410 display and oxygen probe does not impact the 60VA budget for the servos.
2. See nominal ratings on page 6.
3. Ratings for external power supply sizing should be based on peak servo ratings

Cables and Connectors

Cord sets having female connectors on both ends are available in 6 and 40 foot lengths. Field wireable connectors are available in kit form, 129-192. Fireye recommends cable part number 59-565 to be used for servo wiring.

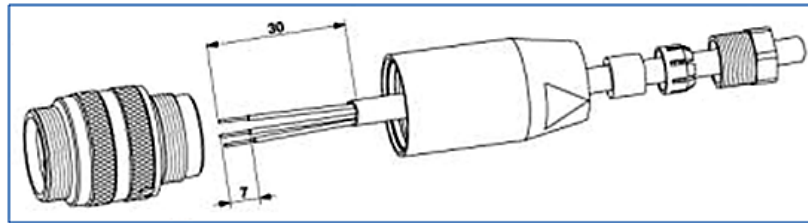

As shown above the cable strip length is specified at 30 mm (1.2 in) and each wire strip length is 7 mm (0.275 in).

To use cable 59-565, strip one end as specified. Strip each wire and wire to connector as shown.

FIGURE 5. Field wireable connector, 129-192

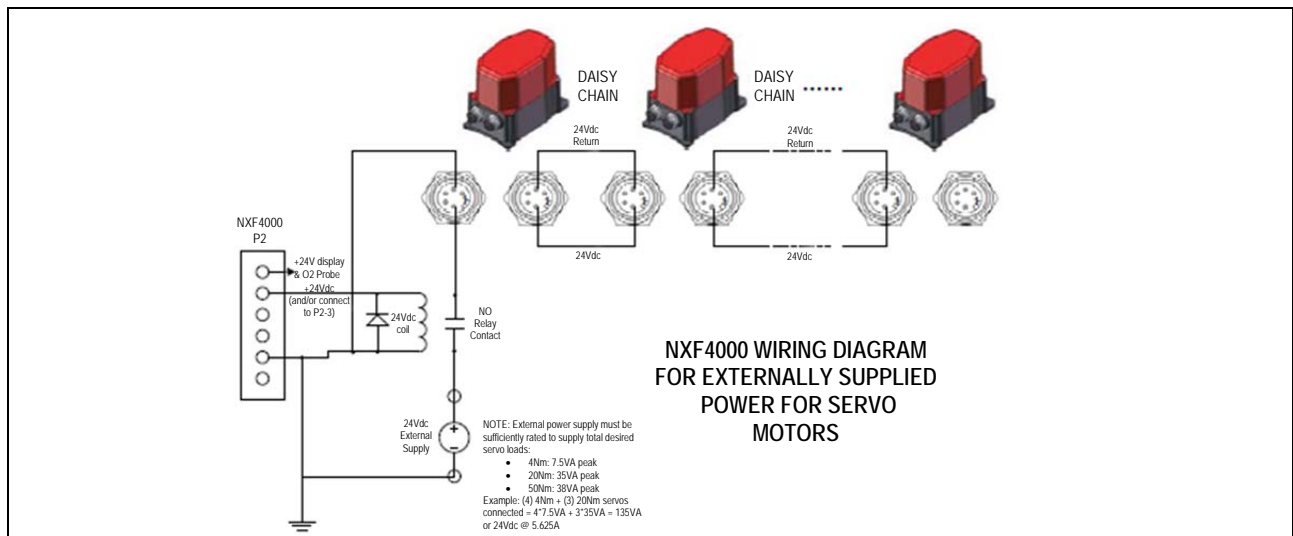
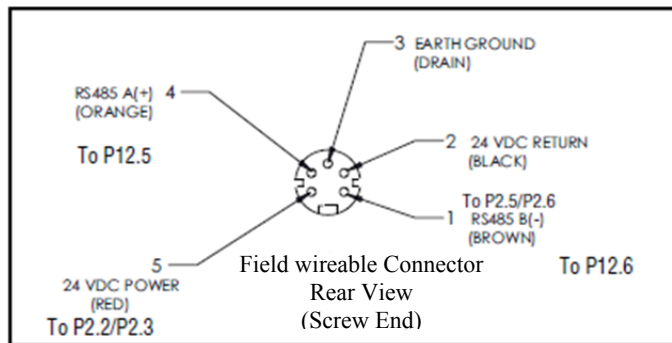

NXCESO2 OXYGEN PROBE

The NXCESO2 oxygen sensing probe is designed to operate with the NXF4000 and provides trimming of the air or fuel servos to maintain predefined O2 target levels resulting in optimum combustion. Refer to Commissioning and Adjust Ratio procedures. The NXCESO2 also provides the stack temperature measurement. The user has the option to activate both O2 level and flue temperature level alarms and the alarms can be selected to be warning or lockout. Refer to O2 setup menu parameters later in this bulletin.

The NXCESO2 is available in 2 probe lengths, 8, and 16 inches to accommodate most stack diameters. The open end of the probe should be located close to the center of the stack (flue).

The NXCESO2 is 24 vdc powered from the NXF4000. Data exchange to and from the probe is done through modbus communications @ 57.6 kbaud using a twisted shielded pair. JP1 is a baud rate selector and must be left in place for proper connection to the NXF4000.

The NXCESO2 contains an integrated cooling fan that is controlled by the on-board microprocessor. The fan will turn on when the internal temperature exceeds 85°C (185°F) and turn off when the temperature drops below 60°C (140°F).

The O2 probe mounts in the stack using Fireye mounting flange kit 35-381-2. See 133-750 for mounting dimensions and instructions.

Recommended Oxygen Probe Mounting Positions

The probe must be mounted in a manner that ensures that the flue gases pass into the gas tube at its open end and out of the tube at the flange end. Furthermore, if possible, the flange should be vertical with the gas tube angled downwards to ensure that particulates do not build up within the sample tube. Probe mounting with the flange horizontal is acceptable. Inverted probe mounting is not acceptable.

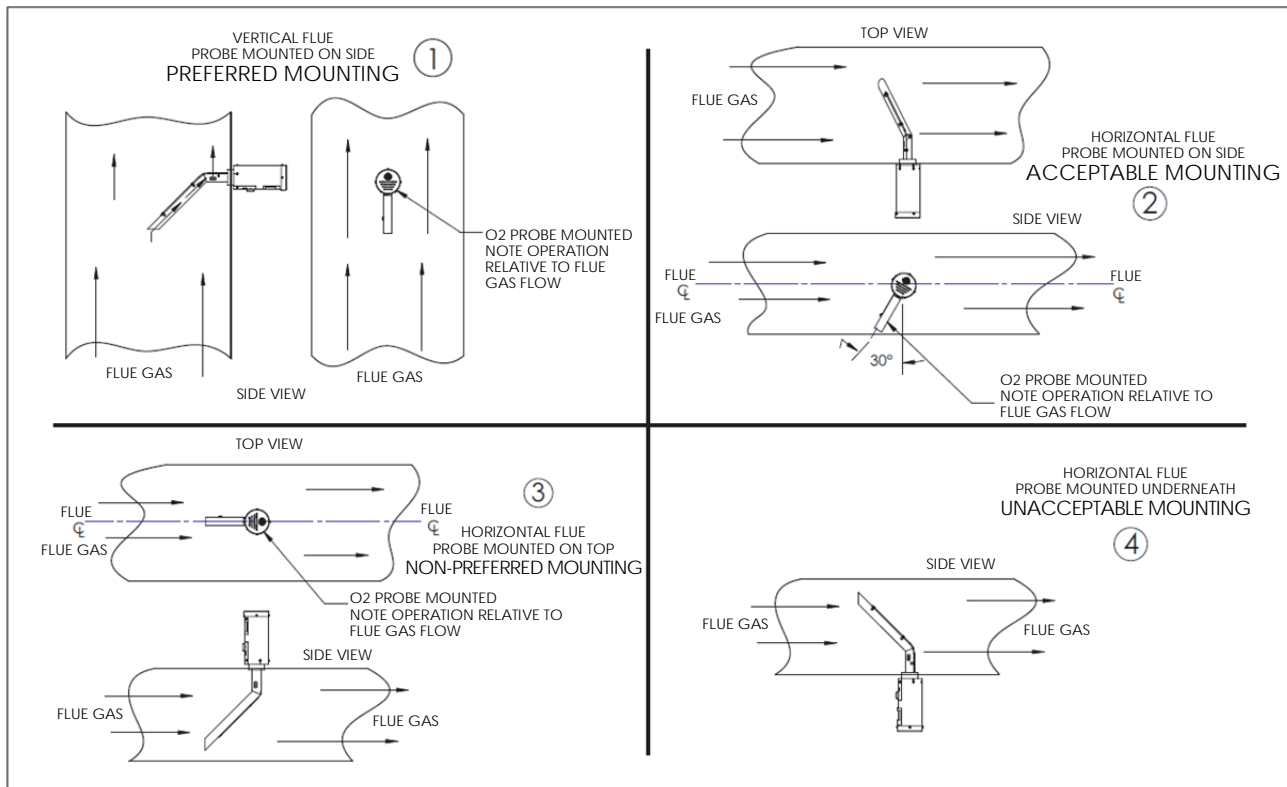

NXCESO2 Dimensional Information

FIGURE 6.

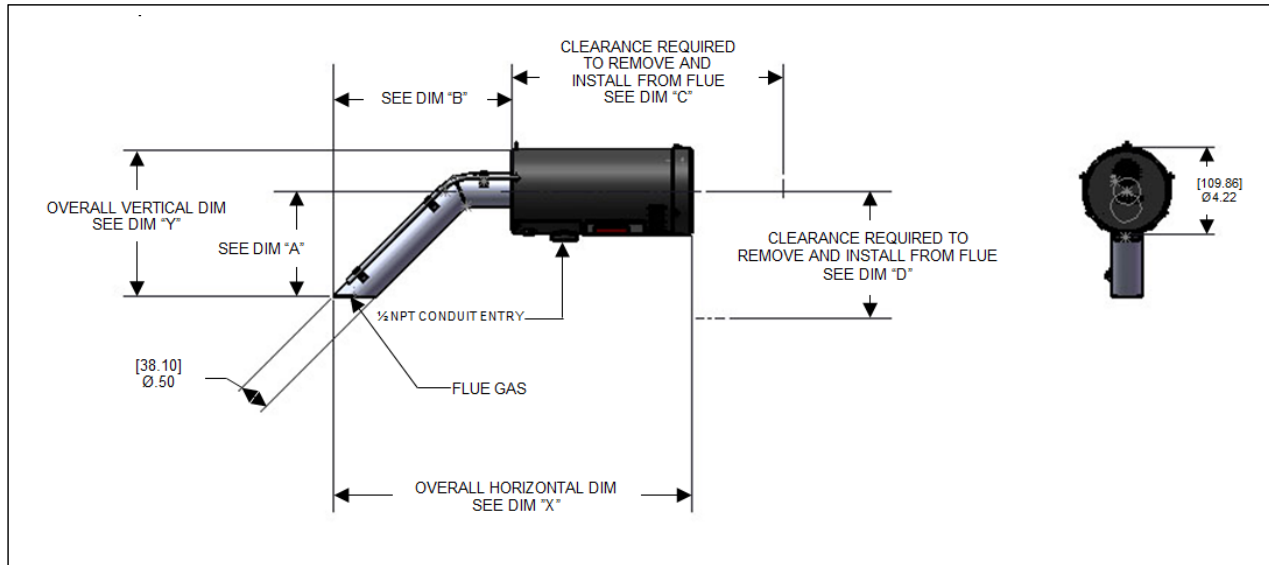

MODEL NUMBER	DIM "A"	DIM "B"	DIM "C"	DIM "D"	DIM "X"	DIM "Y"
NXCESO2-8	(44) 1.69	(216) 8.50	(426) 16.75	(324) 12.75	(445) 17.50	(121) 4.75
NXCESO2-16	(236) 9.22	(407) 16.03	(692) 27.25	(324) 12.75	(637) 25.06	(295) 11.63

Wiring Connections

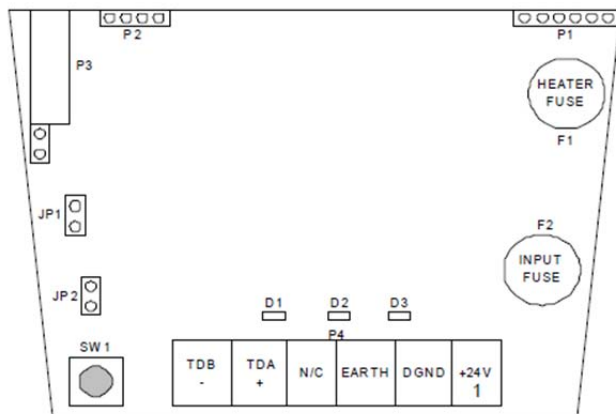

NXCESO2		DESCRIPTION	59-565	NXF4000
6	TDB (-)	MODBUS -	BROWN	P12-12
5	TDB (+)	MODBUS +	ORANGE	P12-11
4	N/C	-	-	
3	EARTH		DRAIN	EARTH
2	DGND	RETURN	BLACK	P2-5
1	+24V	POWER	RED	P2-1

Remove power when servicing

SW 1	Provides fault reset and forced calibration	
JP1	Baud rate selector. In is 57600 (NXF4000), Out is 19200	
JP2	RS485 termination resistor	
F1	Heater Fuse	23-231
F2	Input Fuse	4A, 125V Type LFMX

Refer to Fireye bulletin NXCESO2-1001 for complete details on the O2 probe.

NXD410 User Interface

The NXD410 User Interface provides the means to setup, monitor and display all information from the NXF4000 Control and connected accessories. The NXD410 provides a four line backlit LCD display screen and a multi-function tactile feel keypad. The NXD410 is panel mounted and connects directly to the NXF4000 using Fireye cable 59-562-2.

Explanation of NXD410 keypad

The > and < characters act as alignment indicators. To move to a sub-menu or modify a parameter, the user places the menu line or parameter between these two characters.

Several functions of the NXF4000 will cause the LED associated with that function to illuminate on the keypad.



For any parameter that requires a passcode, pressing a key on the keypad will direct the user to a passcode screen first where the user will input the appropriate level of passcode. If the passcode is currently enabled, pressing a key will direct the user directly to that parameter.

KEYPAD SETUP

Several hot keys on the keypad have a default value of UNUSED. If the user chooses to turn the BURNER ON/OFF using the keypad, the particular key must be activated in the keypad setup menu.









NOTE: If DII was previously set to be used as a BURNER CONTROL switch and its ACTION was AND, using the keypad would be in addition to this. That is, both must be on for this action to take place.

From the top layer menu scroll to KEYPAD SETUP and press NEXT to enter the sub menu.

<	K	E	Y	P	A	D		S	E	T	U	P									
>	B	U	R	N	E	R		O	N	/	O	F	F		U	N	U	S	E	D	<
	A	U	T	O	/	M	A	N							U	N	U	S	E	D	
	L	O	W		F	I	R	E							U	N	U	S	E	D	
	L	E	A	D	/	L	A	G							U	N	U	S	E	D	

The options for each function are UNUSED and USED. Using the MDFY, UP, DOWN and SAVE keys, set BURNER ON/OFF to USED. It is now required to have both the BURNER CONTROL switch going to DII closed as well as the keypad BURNER ON/OFF button depressed to start the burner.

The NXD410 and NXF4000 Control contain a number of Quick Keys that allow the user to access that function directly. For these Quick Keys to operate the installer or operator must first access the KEYPAD SETUP menu where the user defines if a Quick Key is used or unused. Quick Keys are also non-volatile, meaning the state of the switch function is retained in memory should a power recycle occur.

No	LED	Key Name	Description
1		BURNER ON/OFF	KEYPAD SETUP required. Used to turn the burner ON or OFF. Typically there are also other limits in the operating control circuit. The LED indicates the position of the keypad switch and illuminates when the burner is in the ON mode. When turning the burner off via this keypad switch the default method is assured low fire cutoff or move to low fire before OFF.
2		LOW FIRE	KEYPAD SETUP required. If in modulation mode, move servos to low fire position (P03). After burner startup, stay in low fire after MTFI. LED will illuminate when directed to low fire. Pressing AUTO MAN will turn this off.
3		LEAD LAG	Used when SEQUENCING is enabled. If enabled through the sequencing setup sub-menu, selects NXF4000 Control to be MASTER or SLAVE. The LED illuminated indicates the unit is a MASTER. If the SEQUENCING does not provide for keypad selection then this key has no function.
4		AUTO MAN	Switch to automatic control (modulation) mode. LED will illuminate when in manual mode. This can be overridden by LOW FIRE.
5		C-MODE	Go to the Commissioning or Adjust Ratio Mode. LED illuminates when C-MODE is enabled (after passcode enabled). While in Commissioning Mode or Adjust Ratio Mode, hitting C-Mode is used to correctly terminate Commissioning and Adjust Ratio Mode.
6		ADJUST SETPOINT	Directs operator to setpoint currently controlling the burner, SETPOINT1, SETPOINT2, or SETBACK.
7		RESET	Allows reset of non-volatile lockout. LED illuminates when control is in lockout awaiting reset.
8		CHK RUN/ FAULT	Fault History Display and "CHECK" mode activation
9		MODIFY SAVE	MDFY: LED illuminates and enters modify mode. UP/DOWN arrows are used to modify current value. SAVE: Save current parameters/setup, extinguish LED
10		UP	Move up to the previous menu item. When in MODIFY mode, used to increment numerical value.
11		DOWN	Move down to the next menu item. When in MODIFY mode, used to decrement numerical value.
12		NEXT	When displayed item contains > symbol, direct user to the next submenu. Displayed item must be between > < marks on keypad. (Also, when in servo setup, forces scan for installed servos).
13		BACK	When displayed item contains < symbol, direct user to the previous parent menu. Displayed item must be between > < marks on keypad.
14		HOME	From anywhere and in any menu or submenu, immediately suspends any modify mode if enabled and directs user to default or main screen.
15		INFO	Pressing this key will enter INFO mode. Pressing key while in INFO mode, will exit INFO mode. Useful while in commissioning mode to check values of all parameters, digital inputs, measured value, etc.

NAVIGATING THROUGH DISPLAY MENUS

The NXF4000 and NXD410 present data to the user through menus and sub-menus. The data and information is organized in a logical and easy to access manner. The order of items displayed are arranged to be items most used by the operator and require a minimum of key presses. The UP, DOWN, NEXT, BACK and HOME keys are used to navigate into and out of these menus. The MDFY/SAVE key is used to both modify and save the selected parameter.



The HOME key is used to bring the user directly back to the top layer menu and display the default items. Any item in the top layer menu that contains a > character indicates there is a sub menu below it. The NEXT key is used to move to the next sub menu showing parameters for that item. The BACK key is used to revert from the sub menu back to the previous level menu. Various menu items may have several sub menus.

TOP LAYER MENU

F	A	U	L	T		H	I	S	T	O	R	Y						>				
P	A	S	S	C	O	D	E		S	E	T	U	P					>				
O	I	L		T	E	M	P	(3)					1	4	7	F				
S	T	A	C	K		T	E	M	P	(4)			3	2	5	F				
G	A	S		P	R	E	S	(5)		X	X	.	X	i	n	w	c			
1	1	:	3	6	A	M				1	7	-	A	U	G	-	1	0	>			
W	A	I	T		F	O	R		P	U	R	G	E			s	0	6				
HOME	>	S	E	T	P	O	I	N	T					1	2	.	0	p	s	i	<	HOME
M	E	A	S	U	R	E	D		V	A	L		1	0	.	6	p	s	i			
M	O	D	U	L	A	T	I	O	N		R	A	T	E				0	%			
A	I	R	(1)									8	3	.	2					
G	A	S	(2)										4	.	3					
F	G	R	(4)										3	.	4					
F	A	N	(V	F	D	1)								9	8	0				
O	2		L	E	V	E	L								2	0	.	9	%			
C	O	2		L	E	V	E	L								*	*	*				
F	L	U	E		T	E	M	P							1	7	2	°	F			
E	F	F	I	C	I	E	N	C	Y							*	*	*				
S	E	R	V	O		S	E	T	U	P									>			
S	E	N	S	O	R		S	E	T	U	P								>			
S	E	T	P	O	I	N	T		S	E	T	U	P						>			
P	R	O	F	I	L	E		S	E	T	U	P							>			
D	I	G	I	T	A	L		I	N	P	U	T		S	E	T	U	P	>			
O	2		S	E	T	U	P												>			
S	E	Q	U	E	N	C	I	N	G		S	E	T	U	P				>			
T	H	E	R	M	A	L		S	H	O	C	K		S	E	T	U	P	>			
S	E	T	B	A	C	K		S	E	T	U	P							>			
C	O	M	M	U	N	I	C	A	T	I	O	N		S	E	T	U	P	>			
K	E	Y	P	A	D		S	E	T	U	P								>			
S	D		C	A	R	D		O	P	S		S	E	T	U	P			>			
A	N	A	L	O	G		O	U	T		S	E	T	U	P				>			

*NOTE:

Some menu items may not show on the top layer menu. The visibility of the menu items is dependent on the system configuration.



The UP and DOWN keys are used to scroll forward and backward through the top layer menu. The menu is continuous in both directions. That is, when you reach the bottom and continue with the DOWN key, for example, the very top of the menu will be displayed on the next line. As stated earlier, hitting the HOME key from anywhere will bring you back to the HOME screen. The shaded area shown in the Top Layer Menu section on page 25 is the HOME screen. For items that contain the > character, the NEXT key is used to move to a sub menu for that particular item. Also, hitting the BACK key from a sub menu will bring you back to the line item from the menu you left. To move to a sub menu or to modify a parameter, that particular line must lie between the > < characters located on the keypad.

For example, assume you scroll down so the following is displayed:

	F	A	N	(V	F	D	I)										0
>	S	E	R	V	O	S	E	T	U	P									>
	S	E	N	S	O	R	S	E	T	U	P								>
	S	E	T	P	O	I	N	T	S	E	T	U	P						>

Since SERVO SETUP is lying between the > < characters of the keypad, you press the NEXT key to enter the SERVO SETUP sub menu. The shaded area below is an extension of this particular sub menu:

	S	E	R	V	O	S	E	T	U	P									
>	D	I	S	P	L	A	Y	F	O	R	M	A	T				D	E	G
	S	E	R	V	O	S	P	E	E	D							3	0	S
	S	E	R	V	O	S	I	N	S	T	A	L	L	E	D			4	>
	S	E	R	V	O	1										A	I	R	>
	S	E	R	V	O	2										G	A	S	>
	S	E	R	V	O	3										O	I	L	>
	S	E	R	V	O	4										F	G	R	>
	V	F	D	1															>
	V	F	D	2															>

Pressing the BACK key from anywhere in this sub menu will take you back to the top layer menu at the place where you exited the top layer menu. Pressing the HOME key will take you back directly to the HOME screen. For the screen shown above, with DISPLAY FORMAT lying between the > < characters, pressing the MDFY/SAVE key will allow you to scroll through options to select the desired value. Pressing the MDFY/SAVE key will save the selected value. Using the DOWN key to display 'SERVO 1 AIR>' between the > < characters and pressing NEXT will direct you to the SERVO 1 sub menu:

NXF4000 CONTROL OPERATION

This next section will be used to set up a basic low pressure steam boiler system with a single fuel. The application will implement an AIR and GAS servo and use profile 1.

A BLPS pressure sensor is installed and wired, two appropriately sized FX type servos are installed and wired and DI 1 (digital input) is used as the burner ON/OFF input. The servos are setup with unique addresses. For this exercise, assume the servo addresses are 1 for AIR and 2 for GAS. System wiring is done in accordance with Figure 19 (page 90). It is recommended the installer record the low and high fire positions of the air damper and gas butterfly valve and be generally knowledgeable about the burner and its operation.

	<	S	E	R	V	O	1													
>	S	E	R	V	O	N	A	M	E					U	N	U	S	E	D	
	A	S	S	I	G	N	M	E	N	T									0	
	D	I	R	E	C	T	I	O	N										C	W
	S	E	R	V	O	P	O	S	I	T	I	O	N			1	.	0	°	



On first application of power, with conditions as stated above, the display will indicate:

S	T	A	N	D	B	Y											s	0	1				
>	S	E	T	P	O	I	N	T									U	N	U	S	E	D	<
	M	E	A	S	U	R	E	D		V	A	L					U	N	U	S	E	D	
	M	O	D	U	L	A	T	I	O	N		R	A	T	E							0	%

The NON-RECYCLE LIMIT will remain open and the servos will remain at their respective installed positions. For PASSCODE protected parameters, if the passcode is not enabled, the user will be automatically directed to the PASSCODE setup screen.

PASSCODE

The passcode setup screen is as follows:

P	A	S	S	C	O	D	E		S	E	T	U	P										
>	S	I	T	E		C	O	D	E								*	*	*				<
	A	D	J	U	S	T		R	A	T	I	O					*	*	*				
	C	-	M	O	D	E											*	*	*				

At this screen the user scrolls down until the desired passcode level is between the > < characters, presses MDFY to enter modify mode, use the UP / DOWN keys to enter the correct value and presses SAVE to enter the value to the system. A correctly entered passcode will direct the user to the HOME screen as shown above.

The system has 3 levels of pass codes. Out of the box settings for internal PASSCODES are as follows:

Pass Code	Pass Code Level	Code*	Feature
SITE CODE	Level 1	154	Setpoint Setup
	Level 1	154	Sequencing Setup
ADJUST RATIO CODE	Level 2	256	Adjust Ratio Mode
	Level 2	256	O2 Setup
	Level 2	256	Erase Profiles
C-MODE	Level 3	903	Commissioning Mode
	Level 3	903	VFD1 and VFD2 Setups
	Level 3	903	All SDCard Operations
	Level 3	903	Erase All Data
	Level 3	903	Sensor Setup

* Level 1 passcode is changeable (0-999) and has a default of 154. Level 1 pass code protection can be turned OFF by setting it to 0. Level 2 and 3 pass codes are fixed. To change Level 1, the user must:

1. Access the PASSCODE menu, enter the C-MODE Level 3 passcode
2. Go back to the PASSCODE menu, now change the SITE CODE Level 1 passcode as desired

REAL TIME CLOCK

The NXF4000 contains a real time clock that is used to record fault history and implement the setback schedule. To operate properly, the real time clock should be checked and set correctly. If not correctly set the NXF4000 will use the clock information as it is available. The real time clock information is displayed in the top layer menu just above the HOME screen. The UP / DOWN keys are used to position the real time clock information to between the > < marks. Note the default time and date are shown.

P	A	S	S	C	O	D	E		S	E	T	U	P										>		
>	1	2	:	0	0	P	M		0	1	-	J	A	N	-	2	0	1	6				>	<	
	S	T	A	N	D	B	Y													s	0	1			
	S	E	T	P	O	I	N	T		1										U	N	U	S	E	D



The NXF4000 uses 12 hour format only, AM / PM. If the clock and date need adjustment, the NEXT key is pressed to move to the DATE / TIME SETUP submenu.

<	D	A	T	E	/	T	I	M	E	S	E	T	U	P					
>	S	E	T		Y	E	A	R							2	0	1	8	<
	S	E	T		M	O	N	T	H							M	A	Y	
	S	E	T		D	A	Y										1	5	
	S	E	T		H	O	U	R							1	2	P	M	
	S	E	T		M	I	N	U	T	E							3	0	
	S	E	T		S	E	C	O	N	D								0	

Use the UP / DOWN keys to position the item to be modified between the > < marks and use the MDFY/SAVE key to modify and save the new value. When done, press the HOME key to move back to the HOME screen.

NOTICE: The real time clock will reset when power is removed from the NXF4000 controller for more than 2 weeks. If the clock is found to be incorrect, simply access the clock setup menu and make corrections.

SERVO SETUP

From the HOME screen the user scrolls to SERVO SETUP and presses NEXT to enter the sub menu. The following is displayed:

<	S	E	R	V	O		S	E	T	U	P									
>	S	E	R	V	O		S	P	E	E	D							3	0	<
	S	E	R	V	O	S		I	N	S	T	A	L	L	E	D				>
	S	E	R	V	O	I														

The speed of the servos can be selected within the range of 30 to 120 seconds in steps of 5 seconds. This is the speed of the servos to move 90 degrees. Use the UP/DOWN keys to place the item to be modified between the > < characters, press MDFY, use the UP/DOWN keys to select the desired value and then press SAVE. SERVOS INSTALLED is used to direct the control to scan the servo communication port and return the number of servos found. This is done by hitting the NEXT key only. For this example, after doing this, the display should be as follows:

<	S	E	R	V	O		S	E	T	U	P									
>	S	E	R	V	O		S	P	E	E	D							3	0	<
	S	E	R	V	O	S		I	N	S	T	A	L	L	E	D		2		>
	S	E	R	V	O	I														

Scrolling DOWN will show the two installed servos:

<	S	E	R	V	O		S	E	T	U	P										
>	S	E	R	V	O	S		I	N	S	T	A	L	L	E	D		2		>	<
	S	E	R	V	O		1													>	
	S	E	R	V	O		2													>	

The servos must now be configured to operate in the system. This is called naming the servo and tagging the servo to a profile. Scroll so that the SERVO 1 is between the > < characters and press NEXT to enter the SERVO 1 sub menu:

<	S	E	R	V	O		1														
>	S	E	R	V	O		N	A	M	E					U	N	U	S	E	D	<
	A	S	S	I	G	N	M	E	N	T											0
	D	I	R	E	C	T	I	O	N											C	W
	S	E	R	V	O		P	O	S	I	T	I	O	N			1	.	0	°	

The first parameter that must be set is to name the servo. Each servo must be named and at least one servo of each profile must be named AIR. The table below lists the options for naming the servo and also to what profiles the servo is tagged.

NAME	DESCRIPTION
UNUSED	SERVO NOT USED
FU1	FUEL1
FU2	FUEL 2
GAS	GAS
OIL	OIL
CUP	ROTARY CUP
PUM	PUMP
WAS	WASTE FUEL
PRI	PRIMARY AIR
FGR	FLUE GAS RECIRCULATION
AIR	MAIN COMBUSTION AIR
FAN	MAIN COMBUSTION FAN
SEC	SECONDARY AIR
SLE	BURNER SLEEVE

PROFILE ASSIGNMENT VALUE	
DISPLAY VALUE	PROFILES
0	NONE
1	1
2	2
2,1	2+1
3	3
3,1	3+1
3,2	3+2
3,2,1	3+2+1
4	4
4,1	4+1
4,2	4+2
4,2,1	4+2+1
4,3	4+3
4,3,1	4+3+1
4,3,2	4+3+2
4,3,2,1	4+3+2+1 (ALL)

Place the parameter to be modified between the > < characters and using the MDFY, UP, DOWN and SAVE keys, select AIR and profile 1 for servo 1. The options for the servo direction are CW (clockwise) and CCW (counter-clockwise).

NOTICE: It is necessary to ensure that each motor travels in the correct direction to match the mechanical configuration of the burner. The CW setting is for a servo to move counter-clockwise (looking toward the shaft) as the motor is driven toward 90°.

Clockwise rotation shown as viewed from the cover side

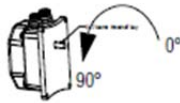

FX04-1

Clockwise rotation shown as viewed from the cover side

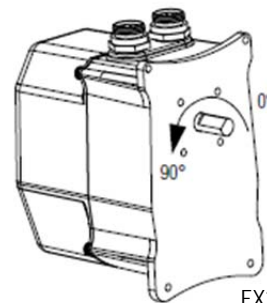

FX20-1

Fireye “D” hole couplings should be used in order to assure a secure connection to the driven member. Set screws alone are not recommended as they can come loose resulting in a potentially unsafe condition. Motor shafts are hardened generally preventing set screws from “biting” in and thus loosening after commissioning. Fireye bulletin NEXBK-1000 provides information on “D” hole couplings.

Move the servo position parameter to between the > < characters. At all times and while in P00 (STANDBY, burner off), the servo can be moved to any position. This is useful for checking the movement of the servo and driven member. Take care not to overdrive the servo such that the driven member is attempting to move beyond its mechanical end stop. The servo can be left in any position as it will be positioned properly during commissioning for all profile setpoints. It is recommended that all servo positions commissioned by the user be between 3° degrees and 97° degrees. To move the servo, press MDFY and using the UP and DOWN

keys, set the target position. In this example set the target position to 10.0 degrees. Press SAVE and the display will indicate the original position and change as the servo is moving toward its target position.

The final display for servo 1 should look like the following:

<	S	E	R	V	O		1															
>	S	E	R	V	O		N	A	M	E								A	I	R	<	
	A	S	S	I	G	N	M	E	N	T											I	
	D	I	R	E	C	T	I	O	N											C	W	
	S	E	R	V	O		P	O	S	I	T	I	O	N				1	0	.	0	°

Press the BACK key to return to the SERVO SETUP sub menu. Select SERVO 2 using the NEXT key to move the SERVO 2 sub menu. Set the parameters for SERVO 2. Name this servo as GAS, tag it to profile 1 and test its servo position for proper function and set its final position to 4.2 degrees. When done the display should be as follows:

<	S	E	R	V	O		2															
>	S	E	R	V	O		N	A	M	E								G	A	S	<	
	A	S	S	I	G	N	M	E	N	T											I	
	D	I	R	E	C	T	I	O	N											C	W	
	S	E	R	V	O		P	O	S	I	T	I	O	N				4	.	2	°	

At this point press the BACK twice to move back to the top layer menu at the point at which we left the top layer menu. Pressing the HOME key would have brought you back to the HOME screen.



CAUTION

On a previously commissioned system, care must be taken when replacing a servo motor believed to be defective. Although every effort is made to calibrate each servo, there may be slight differences from servo to servo. It is strongly recommended the installer, equipped with a combustion analyzer, use ADJUST RATIO to step through each profile that uses the replacement servo. Each profile set point should be checked and adjusted for proper combustion.

SENSOR SETUP

The NXF4000 contains inputs for five analog 4-20 mA transducers. The process control variable (PCV) or the governing sensor for the boiler can only be SENSOR 1. The SENSOR SETUP menu is used to configure the various sensors in the system as to type of sensor and range of sensor.

From the top layer menu move SENSOR SETUP to between the > < characters and press NEXT to enter the SENSOR SETUP sub menu.

<	S	E	N	S	O	R		S	E	T	U	P									
>	U	N	I	T	S								E	N	G	L	I	S	H	<	
	S	E	N	S	O	R		1													>
	S	E	N	S	O	R		2													>
	S	E	N	S	O	R		3													>
	S	E	N	S	O	R		4													>
	S	E	N	S	O	R		5													>

The parameter UNITS is to select units of measurement for all sensors. The options are ENGLISH and METRIC. ENGLISH is PSI and degrees F. METRIC is BAR and mBar and degrees C. This setting is global, meaning it applies to all sensors. Position SENSOR 1 and press the NEXT key to enter the SENSOR 1 sub menu.

<	S	E	N	S	O	R		1													
>	T	Y	P	E										U	N	U	S	E	D	<	
	R	A	N	G	E									U	N	U	S	E	D		

For this application, at SENSOR TYPE press MDFY. Use the UP or DOWN keys to select STEAM and press SAVE. At SENSOR RANGE, press MDFY and use the UP or DOWN keys to select 15 PSI and press SAVE. The display will be as follows:

<	S	E	N	S	O	R		1												
>	T	Y	P	E											S	T	E	A	M	<
	R	A	N	G	E					0	t	o		1	5	p	s	i		

See table 2 for sensor range and settings. Press the BACK key twice to get back to the top layer at the point where we left it or press HOME to go directly back to the HOME screen.



NOTICE: The safety system in the NXF4000 will not allow the sensor configuration to be changed after fully configured, if the sensor is attached to other operating functions like thermal shock or setback. Sensor assignment to those operating functions must be set to UNUSED before the system will allow changes to the sensor configuration.

SENSOR SETPOINT SETUP

In the top layer menu, scroll to SETPOINT SETUP and press NEXT to enter this sub menu. From this menu, select what sensor is used for each setpoint and set the values for that setpoint based on the sensor selected.

The SETPOINT SETUP menu is as follows:

<	S	E	T	P	O	I	N	T		S	E	T	U	P						
>	S	E	T	P	O	I	N	T		1		S	E	T	U	P			>	<
	S	E	T	P	O	I	N	T		2		S	E	T	U	P			>	
	S	E	T	P	O	I	N	T		3		S	E	T	U	P			>	

Select SETPOINT 1 and press the NEXT key to enter the sub menu. The values shown are the default values.

<	S	E	T	P	O	I	N	T		1		S	E	T	U	P					
>	S	E	N	S	O	R		U	S	E	D				U	N	U	S	E	D	<
	L	I	M	I	T		T	Y	P	E									D	E	V
	S	E	T	P	O	I	N	T											N	/	A
	C	U	T		I	N													N	/	A
	C	U	T		O	U	T												N	/	A
	P	-	B	A	N	D													N	/	A
	H	I	G	H		M	A	R	G	N	L								N	/	A
	H	I	G	H		L	I	M	I	T									N	/	A
	I	N	T	E	G	R	A	L													0
	D	E	R	I	V	A	T	I	V	E											0

The values shown above are all default values for SETPOINT 1. For SETPOINT 1 the options for SENSOR are limited to UNUSED and SENSOR 1. Using the MDFY, UP, DOWN and SAVE keys, change SENSOR to 1 and then scroll to change the setpoint to 10.0 PSI. Continue and set cut in, cut out and proportional band (P-BAND) to appropriate values.

For SETPOINT 2, the options for SENSOR are limited to UNUSED, SENSOR 1, and SENSOR 2.

For SETPOINT 3, the options for SENSOR are limited to UNUSED and SENSOR 3.

Definitions:

LIMIT TYPE

DEV - Values that deviated from setpoint. The advantage is these values will float with the setpoint.

SETPOINT - The target pressure or target temperature the control will maintain.

CUT IN (Cut In Value) - Determines the point in which the steam pressure (or water temperature) must reach to start a burner cycle. In DEV option, this a differential value that is subtracted from the steam pressure or water temperature setpoint.

CUT OUT (Cut Out Value) - Determines the point in which the steam pressure (or water temperature) must reach to end a burner cycle and initiate a normal shutdown. In DEV option, this is a differential value that is added to the steam pressure or water temperature setpoint.

P-BAND (Modulating Range) - This determines the proportional band and is the range of steam pressure (or water temperature) in which the firing rate motor is commanded from its low fire (0%) to its high fire position (100%). In DEV option, this is a differential value that is **subtracted** from the steam pressure setpoint or water temperature setpoint.

Whenever the steam pressure (or water temperature) is within the P-BAND, an increase in pressure (or temperature) value will reduce the control signal to the AIR/FUEL servos, causing the servos to drive towards its low fire position. Similarly, a decrease in the steam pressure (or water temperature) will increase the control output signal, causing the valves and dampers to move toward their respective high fire positions.

The value of the **P-BAND** determines how the NXF4000 responds to changes in the measured variable (steam pressure or water temperature). A small modulating range will cause the control to respond quickly to small changes in steam pressure or water temperature. A small value of **P-BAND** might result in the SERVOS to move excessively and possibly cause the burner to actually exhibit short cycle. A large value would reduce the movement of the SERVOS, but may cause the system to be somewhat sluggish in response to a change in steam pressure or water temperature. Matching the capacity of the boiler to load system demand are important considerations in setting the **P-BAND** setpoint. Care should be taken when selecting this variable.

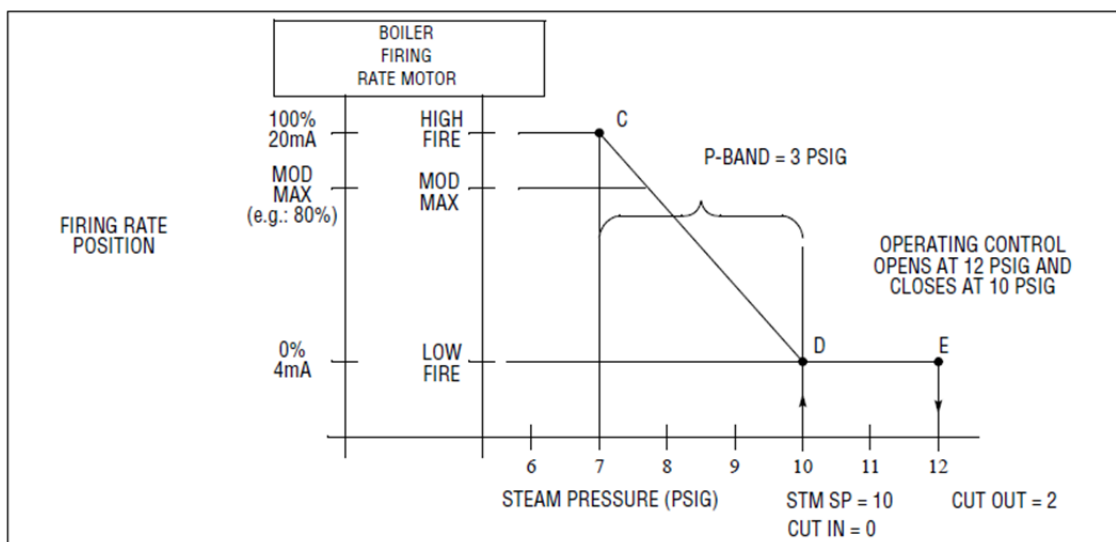

HIGH MARGINAL - Provides an indication that the sensor value is approaching the high alarm limit before the alarm limit is actually reached. For example, a Marginal Stack Alarm may be an indication of the burner overfiring, fouled heat exchanger, tube leak in heat exchanger, etc. If the HIGH MARGINAL is exceeded for 4 seconds, the alarm relay will be activated but the system will not go to lockout.

HIGH LIMIT - When this is exceeded, the NXF4000 will proceed to lockout.



The user programs both HIGH MARGINAL and HIGH LIMIT for the temperature or pressure sensors based on the input signal received. The HIGH MARGINAL cannot be set higher than the HIGH LIMIT nor can either be set lower than the sum of SETPOINT plus CUT OUT. Alarm points for stack monitoring can be set anywhere within the sensor range.

Both INTEGRAL and DERIVATIVE terms are used to eliminate steady-state error and reduce overshoot. They each have a range of 0 to 100%. This value determines how much of the error to factor in the calculation. A value of 0 turns the function off.

When completed, press the BACK key to get back to the top layer menu at the point of exiting or press the HOME key to go directly to the home screen.

PROFILE SETUP

In the top layer scroll to PROFILE SETUP and press NEXT to enter this sub menu. This menu provides the means to name the profile, set the maximum modulation rate for this profile and when necessary erase the profile setpoints.

<	P	R	O	F	I	L	E		S	E	T	U	P							
>	P	R	O	F	I	L	E	1								N	O	N	E	>
	P	R	O	F	I	L	E	2								N	O	N	E	>
	P	R	O	F	I	L	E	3								N	O	N	E	>
	P	R	O	F	I	L	E	4								N	O	N	E	>
	C	L	E	A	R		C	O	N	F	I	G		D	A	T	A		N	O

Using the NEXT key, select PROFILE 1.

<	P	R	O	F	I	L	E		S	E	T	U	P								
>	P	R	O	F	I	L	E	1								N	O	N	E	>	
	M	A	X		M	O	D	U	L	A	T	I	O	N			1	0	0	%	
	M	I	N		M	O	D	U	L	A	T	I	O	N						0	%
	E	R	A	S	E		P	R	O	F	I	L	E							N	O

Using the MDFY, UP, DOWN and SAVE keys, scroll through the choices for naming this profile and select GAS as the name. MAX MODULATION sets the maximum firing rate of the burner or inhibits the burner from reaching 100% modulation rate.



CAUTION: ERASE PROFILE will clear all setpoints from P01 to P23 for the profile selected. Executing this option will require a new commissioning of the burner. CLEAR CONFIG DATA clears all setpoint data and all profiles restoring to factory default. A complete control setup (servos, sensors, setpoints, inputs, keypad, etc.) and burner commissioning is required after executing this command. Both ERASE PROFILE and CLEAR ALL CONFIG are passcode protected. **Care must be taken before using these commands and it's recommended to backup the system with SDCARD (16GB media pre-installed).**

BURNER CONTROL SETUP

The NXF4000 offers a burner control setup menu that allows the user to configure key burner timings and operational parameters. The setup menu controls the behavior of the relays that are used to energize the fuel valves, purge times, post-purge times, flame failure response times, etc. The menu can be accessed using the keypad and access requires a level 3 passcode:

<	B	U	R	N	E	R		C	N	T	R	L		S	E	T	U	P				
>	P	R	O	V	E		P		O	P	E	N							N	O	>	
	P	U	R	G	E		T	I	M	E						0	:	3	0			
	P	O	S	T		P	U	R	G	E		T	I	M	E				0	:	1	5
	R	E	C	Y	C	L	E													N	O	
	P	T	F	I		T	I	M	E							1	0	/	1	0		
	M	T	F	I		T	I	M	E							1	0	/	1	5		
	P	I	L	O	T					I	N	T	E	R	R	U	P	T	E	D		
	F	F	R	T											4				s	e	c	
	P	R	O	V	E		A	I	R	F	L	O	W						Y	E	S	
	P	R	O	F	I	L	E		S	E	L	E	C	T					A	U	T	O
	E	N	A	B	L	E		R	U	N	/	C	H	E	C	K					N	O
	S	C	A	N	N	E	R		T	Y	P	E									U	V
	V	A	L	V	E		P	R	O	V	I	N	G									>

The various setup parameters are explained below

PROVE P OPEN ► Settings NO, YES - default NO.



This burner control setup parameter verifies the non-recycle limit chain (P5.10) before commencing a burner sequence. This is particularly useful for a system that offers the airflow switch in the non-recycle chain.

When set for YES, the limit chain is proven such that it must be open in order for the burner sequence to start. The NXD410 display would show "P CLOSED" if the verification condition is not satisfied.

PURGE TIME ► Settings 0:00 to 60:00, 5sec increments - default 0:30

The purge time can be adjusted to provide the necessary air exchanges need to clear the combustion chamber of unburnt fuel at the start of a combustion cycle.

POST PURGE TIME ► Settings 0:00 to 1:00, 5sec increments - default 0:15

The post purge time can be adjusted to provide the necessary air exchanges need to clear the combustion chamber of unburnt fuel at the end of a combustion cycle.

RECYCLE ► Settings NO, YES - default NO.

The recycle parameter dictates how the system responds to non-recycle interlock limit (P5.10) opening during burner operation. Setting the parameter to 'YES' forces the system to end the current burner cycle and initiate a new cycle; setting the parameter to 'NO' forces the system to proceed to a lockout state.

PTFI TIME ► Settings 10/10, 5/15, 5/10, 5/5, 3/6, 3/8, 3/13 – defaults: **110V** → 10/10; **230V** → 3/8

The Pilot Trial For Ignition (PTFI) timing controls the amount of time (in seconds) that the Ignition (P5.6) and Pilot (P5.7) outputs are active before the flame is proven to be on. The first number is the ignition time; the second number is the pilot time (Ignition/Pilot). Timing '5/10' is generally used for early spark termination as this would terminate the ignition earlier than the pilot.

MTFI TIME ► Settings 10/15, 10/10, 3/5, 0/15, 0/10, 0/5, 0/3 - defaults: **110V** → 10/15; **230V** → 0/5

The Main Trial For Ignition (MTFI) timing controls the time (in seconds) that the Ignition (P5.6) and Pilot (P5.7) outputs are active during the main flame establishment period (MFEP). In other words, it is the extension of the Pilot/Ignition outputs after the pilot flame is established and the Main fuel valves (P5.4, P5.5 and P5.8) are energized. The first number is the Ignition time; the second number is the Pilot time (Ignition/Pilot). Use setting 0/15, 0/10, 0/5, or 0/3 for no spark during main fuel ignition.

PILOT INTERRUPTED ► Settings INTERRUPTED, INTERMITTENT - default INTERRUPTED.

An 'Interrupted' setting forces the termination of pilot after the main flame is established. An 'Intermittent' setting allows the pilot to remain active during MTFI and AUTO states (when the main fuel valves are energized). An intermittent setting ignores the pilot settings defined in MTFI TIME.

FFRT ► Settings 1sec, 2sec, 3sec, 4sec - defaults: **110V** → 4sec; **230V** → 1sec

FFRT is the Flame Failure Response Time. This is the time required for the control to de-energize the main fuel shutoff valve(s) in the event of a flame out condition. Please consult local codes or Burner manufacturer to determine the required setting.

PROVE AIRFLOW ► settings YES, NO - default YES.

The NXF4000 is capable of proving the airflow switch position in a stand-alone fashion. Certain regulations require the Normally-Closed and Normally-Opened position of the airflow switch to be proven independent of the non-recycle interlock chain. When the appropriate digital inputs are configured (see digital input section), this setting allows the system to prove the airflow switch position during the burner sequence.

PROFILE SELECT ► settings AUTO, 1, 2, 3, 4 - default AUTO

Select AUTO to allow the NXF4000 to scan the four PROFILE inputs for a HI (powered) input upon call for heat. These inputs are: P15.5 (Profile 4), P15.6 (Profile 3), P15.7 (Profile 2) and P15.8 (Profile 1). When the PROFILE SELECT menu selection is not AUTO, the selected profile (1, 2, 3, 4) takes precedence and overrides the wired input selection. If your profile switch on your control panel is set for PROFILE 1, you can override the switch setting through the PROFILE SELECT menu.

ENABLE RUN/CHECK ► settings YES, NO - default NO

This setting enables the CHK/RUN/FAULT button functionality on the User Interface display for 2 hours. Pressing any display key/button when active will reset the timer for 2 hours.



When configured for YES, the user gains the ability to freeze the burner sequence at the following states: PURGE, IGNITION, PTFI, and PILOT. Thus, allowing for adjustment of the burner/boiler system during setup, commissioning or maintenance. In the pilot state, the state freeze timer expires in 30 seconds.

To perform the RUN/CHECK, the user must first activate the CHECK functionality in the Burner Control Setup Menu and then press the RUN/CHK button on the display and the associated LED on the button will be illuminated. The button must be pressed again to disable the state freeze in order for the system to proceed normally. If the system is idle for 2 hours while in CHECK mode, the system will automatically disable the RUN/CHK functionality and proceed to lockout.

NOTE: RUN/CHECK is automatically enabled during Commissioning.

Digital Inputs can be configured to enable or disable RUN/CHECK. After enabling the RUN/CHECK operation in the Burner Control Sub-menu, when line voltage is applied to the configured digital input, the RUN/CHECK feature is enabled. Removing line voltage from the configured digital input disables RUN/CHECK. Please see the digital input section for more information.

SCANNER TYPE ► UV (For UV amplifier system)

Certain regulations require a boiler system designed for permanent operation (more than 24hrs of continuous burner operation) to utilize a self-checking scanner. Such system must utilize a setting of UVSC. Systems designed for non-permanent operation may choose a setting of UV.

It's expected that the system installer is aware of national and local regulations and the appropriate flame sensing scanner must be installed for normal and safe burner/boiler operation. The following approved scanners are compatible with the NXF4000 system:

Non-permanent operation UV scanners: UV90L-1, UV1AL-3, UV1AL-6, UV5-1

SCANNER TYPE ► IR (For IR amplifier system)

A boiler system fitted with the appropriate IR flame scanner is capable of operating in permanent or non-permanent operation. The following approved scanners are compatible with the NXF4000 system:

IR scanners: 48PT2-1003, 48PT2-9003, 48PT2-1007, 48PT2-9007.

SCANNER TYPE ► DC (For Direct-Coupled systems)

For boiler systems fitted with Fireeye's advance integrated flame scanners or flameswitches, the DC amplifier plug-in card allows the control to obtain the flame signal state from the integrated flame scanner: this is achieved by attaching the S1 & S2 terminals to the appropriate flame relay contacts on the integrated flame scanner. The following approved integrated flame scanners and flameswitches are compatible with the NXF4000 system (please see the appropriate integrated flame scanner bulletin for more information):

Integrated flame scanners: Phoenix, InSight1, and InSight2 scanners

Flame-switches: MBCE-FR, MBCE-UV

VALVE PROVING ► This configurable menu option allows the control to properly perform a gas valve proving operation. Gas pressure switch contacts must be wired to the digital inputs and properly configured. Please consult the valve proving section for additional information. The available options under the valve proving menu are:

>	U	S	E				V	A	L	V	E		P	R	O	V	I	N	G	<		
	A	S	S	I	G	N	M	E	N	T							3	,	I			
	A	C	T	I	O	N											N	/	A			
	T	E	S	T		T	I	M	E		1				2	5		s	e	c		
	T	E	S	T		T	I	M	E		2				2	5		s	e	c		
	M	E	T	H	O	D								2	-	V	A	L	V	E		
	T	E	S	T		A	T						P	R	E		P	U	R	G	E	

Assignment - this setting determines the profile to associate with valve proving. Gas valve proving are generally performed for Natural Gas applications.

Test Time 1 - this is the valve proving test time for the atmospheric test to verify leakage of upstream valve (double block valve farthest from the burner). Range is 0 - 60 seconds, default 25 seconds.

Test Time 2 - this is the valve proving test time for the pressurization test to verify leakage of downstream valve (double block valve closest to the burner). Range is 0 - 60 seconds, default 25 seconds.

Test Method - this option allows the control to properly test a double-block gas train system with/without a VENT valve. The available options are 2-VALVE (default), 3-VALVE (Normally Opened VENT) or 3-VALVE (Normally Closed VENT). The dedicated vent valve terminal (P5.9) must be connected to the vent valve for a double-block gas train with vent valve.



WARNING: If an application calls for a vent valve and the vent terminal is connected, the Test Method must be configured appropriately for either 3-VALVE_NO or 3-VALVE_NC. This will ensure that the vent valve is controlled properly during burner standby and burner sequence. Failure to properly configure the test method may result in the vent valve being stuck open.

Test At - this option allows the user to select the burner sequence state to perform the valve proving test operation. Setting is PRE PURGE, POST PURGE - default PRE PURGE. Testing at PRE-PURGE implies that the valve proving operation is performed prior to the pre-purge cycle. Testing at POST-PURGE implies that the valve proving operation is performed after the post-purge cycle. The blower motor terminal stays energized during the valve proving operation.



WARNING: Fireye expects that the valve proving setup and system commissioning must be performed by qualified personnel. National and local regulations must be adhered to when installing and setting up a valve proving system.

FAST GAS VALVE ► Settings 20ms to 150ms, 2ms increments - defaults: **110V** → 20ms; **230V** → 150ms

The fast gas valve configurable parameter allows the control to react to fast line disturbances or interrupts that could trip the main gas shutoff valve(s). The setting is particularly useful for Maxon valves which could potentially react to one missing line cycle. Setting it for 20ms provides the fastest reaction time, while a setting of 150ms provides the slowest reaction time.

FAST OIL VALVE ► Settings 20ms to 150ms, 2ms increments - defaults: **110V** → 20ms; **230V** → 150ms

The fast oil valve configurable parameter allows the control to react to fast line disturbances or interrupts that could trip the main oil shutoff valve(s). Setting it for 20ms provides the fastest reaction time, while a setting of 150ms provides the slowest reaction time.



WARNING: Please consult the burner and/or fuel valve manufacturer to determine the best setting. National and local regulations must be adhered to when setting up the fast gas and/or oil valve parameters. Failure to properly configure the fast gas and/or fast oil valve parameters could lead to a safety condition, which may lead to the loss of property or lives.

DIGITAL INPUT SETUP

The NXF4000 provides the user with fifteen (15) line voltage operated digital inputs. The digital inputs are located in the terminal block P13.1 (DI1) through P13.10 (DI12) and P15.1 (DI13) through P15.3 (DI15). All digital inputs are user defined from a list of functions. The same function can be tagged to multiple digital inputs. Some of the selectable digital input functions duplicate what is available through the keypad function keys: BURNER CONTROL, MANUAL MODULATE, SEQUENCING, and LOW FIRE HOLD. The NXF4000 provides the user with the option of AND'ing and OR'ing these functions with the dedicated key-pad functions or with other digital inputs configured as the same function. When selected as AND, it is required that all inputs be active for the function to be realized. The OR function requires either digital input or keypad function to be active for the function to be realized.

From the top layer menu scroll to DIGITAL INPUT SETUP and press the NEXT key to enter the sub menu.

<	D	I	G	I	T	A	L	I	N	P	U	T	S	E	T	U	P	>
>	D	I	1															>
	D	I	2															>
	D	I	3															>
	D	I	4															>
	D	I	5															>
	D	I	6															>

D	I	7															>
D	I	8															>
D	I	9															>
D	I	1	0														>
D	I	1	1														>
D	I	1	2														>
D	I	1	3														>
D	I	1	4														>
D	I	1	5														>

If DIGITAL INPUT 1 (DI1) is to be set as BURNER CONTROL, at DI1 press the NEXT key to configure –

>

<	D	I	1														<	
U	S	E			B	U	R	N	E	R		C	O	N	T	R	O	L
A	S	S	I	G	N	M	E	N	T							N	/	A
A	C	T	I	O	N											A	N	D

The list of general purpose USE cases for all digital inputs is as follows:

>

																			U	N	U	S	E	D													
						B	U	R	N	E	R		C	O	N	T	R	O	L								<										
						S	E	T	P	O	I	N	T	2		S	L	C	T																		
								L	O	W		F	I	R	E		H	O	L	D																	
										A	L	A	R	M		R	E	S	E	T																	
						M	A	N	U	A	L		M	O	D	U	L	A	T	E																	
						O	2		T	R	I	M		D	I	S	A	B	L	E																	
									F	O	R	C	E	D		S	E	T	B	A	C	K															
									S	E	T	B	A	C	K		O	V	E	R	I	D	E														
								F	O	R	C	E		S	E	Q	.	M	A	S	T	E	R														
																S	E	Q	U	E	N	C	I	N	G		O	F	F								
																					T	R	A	C	K		O	N									
																					L	O	C	K	O	U	T										
																					G	V	P		N	O	R	M	.	O	P	E	N				
																					G	V	P		N	O	R	M	.	C	L	O	S	E	D		
																						G	E	N	E	R	I	C									
																						P	U	R	G	E		H	O	L	D						
																						F	V	E	S	/	P	O	C								
																						R	U	N	/	C	H	E	C	K							
																						A	I	R	F	L	O	W		N	.	C	L	O	S	E	D
																						A	I	R	F	L	O	W		N	.	O	P	E	N		

DIGITAL INPUT OPTIONS

The NXF4000 offers 15 flexible digital input configuration options for various control usage. Some common options are predefined and available for quick configuration. There is a GENERIC input option that allows the user to define how, when, and where the input is evaluated during the burner sequence. Here are the available options:

- UNUSED** ► This implies that the Digital Input is not configured.
- BURNER CONTROL** ► This setting allows the control to turn the burner ON/OFF using the digital input. The operation of this setting is impacted by the keypad Burner ON/OFF key.
- SETPOINT 2 SELECT** ► This setting allows the control to select Setpoint 2 as the controlling function. Setpoint 2 must be configured properly in the setpoint menu in order to select the feature via the digital input.



LOW FIRE HOLD ► This setting allows the control to maintain a low fire modulation rate using the digital input. The operation of this setting is impacted by the keypad Low Fire key.

ALARM RESET ► When active, the digital input allows the user to remotely reset the control during a lockout event. Regulation prohibits the system from allowing more than 5 reset attempts in a 15-minute window. See LOCKOUT section for additional information.

MANUAL MODULATE ► This setting gives the user the ability to place the control in Manual Modulation Mode. Manual adjustment of the modulation rate can further be done using the keypad or via Modbus. The operation of this setting is impacted by the keypad AUTO/MAN key.

O2 TRIM DISABLE ► When active, the digital input gives the user the ability to disable the O2 trim feature. This feature is useful during system maintenance.

FORCED SETBACK ► When active, the digital input gives the user the ability to force the system to transition to setback mode. Setback must be configured properly in the setback menu in order to select the feature via the digital input.

SETBACK OVERRIDE ► This feature allows the user to bypass a scheduled setback operation temporarily. Setback must be configured properly in the setback menu (per the SETBACK OVERRIDE parameter -- see SETBACK section) in order to select the feature via the digital input. Momentary switch is recommended for "make-break" operation.

FORCE SEQ. MASTER ► This feature allows the user to select a sequencing master (lead boiler) in a sequencing chain. Sequencing must be configured properly in the sequencing menu in order to select the feature via the digital input.

TRACK ON ► When the control's PCV/Sensor1 is configured for Track Modulation, the digital input forces the control to enable the track modulation operation by the application of line voltage. The removal of line voltage to the digital input forces the control to a standby state, while still maintaining its ability to respond to standby water and thermal shock operations.

LOCKOUT ► The option is used to force a lockout condition whenever line voltage is applied to the input. A momentary switch is recommended for such purposes.

GVP NORM. OPEN ► This option is used to configure the normally-open position of the gas pressure switch for systems equipped to perform gas valve proving. See Valve Proving section for more details.

GVP NORM. CLOSED ► This option is used to configure the normally closed position of the gas pressure switch for systems equipped to perform gas valve proving. See Valve Proving section for more details.

GENERIC ► The generic setting allows the user to define how, when, and where to evaluate the digital input and the transition to a different state when the conditions are valid. When set, the generic digital input menu expands to:

	U	S	E											G	E	N	E	R	I	C	
>	A	S	S	I	G	N	M	E	N	T								3	,	1	<
	A	C	T	I	O	N												A	N	D	
	S	T	A	T	E													A	L	L	
	I	N	P	U	T																0
	G	O	T	O										L	O	C	K	O	U	T	

Assignment - this setting determines the profile to associate with generic digital input.

Action - this option allows the user to apply logic to how generic inputs are evaluated. An 'AND' setting will force the control to include the logic state of other generic inputs before a true/false decision is made. An 'OR' setting treats the generic input as a unique input and the control makes a true/false decision whenever there is a state change to the digital input. The default logic operation is 'AND'.

State - The state setting allows the user to set the burner sequence phase at which the generic input logic is evaluated. The available burner sequence phases are: ALL, AFTER PREPURGE, HF PURGE ONLY, AFTER HF PURGE, AFTER LF PURGE, and PTFI-MTFI. The default state is ALL.

Input State - This setting can be used by the user to determine if the generic logic should be evaluate at the introduction of line voltage (logic "1") to the digital input or the removal of line voltage (logic "0") from the digital input. The default logic is "0".

Goto - This setting allows the user to set the resulting state/behavior of the control when the generic input conditions are found to be valid. The available options are: LOCKOUT, STANDBY 1S, STANDBY 3S, and ALARM. The ALARM option will engage the alarm relay without influencing the burner sequence. STANDBY 1S or STANDBY 3S implies that the control will revert to the standby state if the condition is valid after 1 second or 3 seconds, respectively.

PURGE HOLD ► The purge hold digital input setting allows the user to keep the control in purge indefinitely when active.

FVES/POC ► The fuel valve end switch (FVES) or proof of closure (POC) is needed in most applications to prove the closure of the main fuel shutoff valve(s) before the start of a combustion cycle. When configured, the NXF4000 expects the fuel valve to stay closed during STANDBY, PURGE, PTFI and POST PURGE states. The fuel valve is expected to be open during MTFI, AUTO, and VALVE PROVING states. Failure to properly prove the POC/FVES will result in a lockout. Digital input 15 is configured for FVES/POC by default.



NOTICE: As a result of the valve proving feature, it's recommended that the mechanical valve switch for POC should be mounted on the downstream gas (MV2) block.

RUN/CHECK ► This setting gives the user the ability to enable or disable the RUN/CHECK operation via the digital input. See the BURNER CONTROL SETUP section for information on run/check operation.

AIRFLOW N. CLOSED ► The digital input option allows the system to prove the airflow switch in the normally-closed position (when system is in standby or blower motor is off). Failure to effectively prove the airflow switch would result in a lockout.

AIRFLOW N. OPEN ► The digital input option allows the system to prove the airflow switch in the normally-open position (while system is running or blower motor is on). Failure to effectively prove the airflow switch would result in a lockout.



NOTICE: Some regulations require both contacts of the airflow switch to be proven for normally-open and normally-closed actions, however, the control provides the flexibility of configuring just one of the positions. If the user elects to configure only one position of the airflow switch, the control will simply qualify that position during operation. It is the responsibility of the user to verify that the configuration meets national and local safety codes.

"AND/OR" FUNCTION EXPLAINED

For functions that duplicate the keypad functions, the user may select if the digital input is AND'ed or OR'ed with this function.

1. Selecting the AND requires both or all of the digital inputs of this function to be active along with the keypad function for the function to be realized.
2. Selecting OR requires either the keypad or the digital input to be active for the function to be realized

Should the user select multiple digital inputs for the same function and then choose some of the same inputs to be AND'ed and OR'ed, the AND'ed requires these to be active to realize the function. For inputs that are set for logic OR, any active input will cause the function to be realized.

Assume the LOW FIRE function on the keypad is set to USED and DI2 is set to LOW FIRE HOLD and its logic state is set to AND. Assume DI3 is set to LOW FIRE HOLD and its logic state is set to OR. To realize the LOW FIRE HOLD function the requirement is the keypad LOW FIRE and DI2 both must be active or DI3 alone must be active. The keypad function can be set to UNUSED and only the digital inputs can be used to realize the function. If only one digital input is used and is set to AND then this alone being active will realize the function.



USER OUTPUT SETUP

The NXF4000 offers a 3 programmable user relay outputs that can be used for various signalling purposes. These are strictly line voltage outputs that can be configured to be active during burner sequence states, lockout events, alarm events, etc.

NOTE: The programmable relay outputs are deemed non-safety rated and they cannot be used for safety critical purposes like energizing fuel valves or solenoid.

From the top layer menu, scroll to USER OUTPUT SETUP and press the NEXT key to enter the sub menu:

<	U	S	E	R		O	U	T	P	U	T		S	E	T	U	P		
>	U	S	E	R		O	U	T	P	U	T		1						>
	U	S	E	R		O	U	T	P	U	T		2						>
	U	S	E	R		O	U	T	P	U	T		3						>

If USER OUTPUT 1 is to be set to be active at HIGH FIRE, select the USER OUTPUT 1 and press the NEXT key to display the following:

<	U	S	E	R		O	U	T	P	U	T		1							
>	U	S	E									H	I	G	H		F	I	R	E
	A	S	S	I	G	N	M	E	N	T							2	.	1	

The list of USE functions for user outputs are:

>																			U	N	U	S	E	D								
												A	L	W	A	Y	S		O	N				<								
							M	I	R	R	O	R			I	N	P	U	T			1										
							M	I	R	R	O	R			I	N	P	U	T			2										
							M	I	R	R	O	R			I	N	P	U	T			3										
							M	I	R	R	O	R			I	N	P	U	T			4										
							M	I	R	R	O	R			I	N	P	U	T			5										
							M	I	R	R	O	R			I	N	P	U	T			6										
							M	I	R	R	O	R			I	N	P	U	T			7										
							M	I	R	R	O	R			I	N	P	U	T			8										
							M	I	R	R	O	R			I	N	P	U	T			9										
							M	I	R	R	O	R			I	N	P	U	T			1	0									
							M	I	R	R	O	R			I	N	P	U	T			1	1									
							M	I	R	R	O	R			I	N	P	U	T			1	2									
							M	I	R	R	O	R			I	N	P	U	T			1	3									
							M	I	R	R	O	R			I	N	P	U	T			1	4									
							M	I	R	R	O	R			I	N	P	U	T			1	5									
															F	L	A	M	E		O	N										
															L	O	C	K	O	U	T											
															O	N	/	O	F	F		S	T	A	T	E						
																		L	O	W		F	I	R	E							
																		H	I	G	H		F	I	R	E						
																		M	A	R	G	I	N	A	L	1						
																		M	A	R	G	I	N	A	L	2						
																		M	A	R	G	I	N	A	L	3						
																		M	A	R	G	I	N	A	L	A	L	L				
																		O	2		T	R	I	M		L	I	M	I	T		
																		H	I	G	H		F	L	U	E		T	E	M	P	
																		O	2		P	R	O	B	E		L	I	M	I	T	S
																						A	L	L		L	I	M	I	T	S	

The various setup parameters are explained below:



ALWAYS ON ► The output terminal is energized whenever the profile it's assigned to is active. This could be used to indicate which fuel is being used.

MIRROR INPUT x ► The state of the input terminal indicated by "x" will be duplicated by the output. Since there are 15 different inputs, there will be 15 values of "x" numbered 1 through 15. This could be used to indicate when the air flow switch is made if the user connects the air flow switch to one of the digital inputs or when the fuel valve is open.

FLAME ON ► The output terminal will be energized whenever a flame signal is detected even if it is a false flame signal.

LOCKOUT ► The output terminal will be energized whenever the NXF4000 is in Lockout. Since no profile is selected when in Lockout, the ASSIGNMENT for this item will be fixed at N/A.

STATE ON/OFF ► The user selects at which operational state the output terminal will be energized and at which operational state the output will be off. This requires two additional sub menu items: ON and OFF. The choices for both ON and OFF will be the names of the states: STANDBY, WAIT FOR PROFILE, GAS VALVE PROVE1, GAS VALVE PROVE2, GAS VALVE PROVE3, GAS VALVE PROVE4, MOVE TO PURGE, PURGE, MOVE TO IGNITION, PTFI, PILOT, MTFI, MFEP, MOVE TO LOW FIRE, AUTO, POST PURGE, and LOCKOUT. The only restriction to which state the user can choose for ON and OFF is that they cannot be set to the same state. Default for ON is STANDBY and default for OFF is LOCKOUT.

LOW FIRE ► The output terminal will be energized whenever the actual modulation rate is less than 6% and will be de-energized when the modulation rate is greater than 11% while in AUTO. When not in AUTO, when the master servo is within 5 degrees of P02 position, the relay will be energized.

HIGH FIRE ► The output terminal will be energized whenever the actual modulation rate is over 93% and de-energized when the modulation rate is less than 88% while in AUTO. When not in AUTO, when the master servo is within 5 degrees of P01, the relay will be energized.

***Alarm notification note:** If this user output is configured, the normal ALARM terminal being energized whenever the Marginal Limit for Sensor 1, 2, 3, O2 Trim Limit, High Flue Temp, or O2 Probe limits has been reached will not occur. Instead, the selected output terminal will be energized. This effectively transfers the function of notifying the user from the ALARM terminal to the selected terminal.*

MARGINAL 1 ► The output terminal will be energized whenever the Marginal Limit for Sensor 1 has been reached.

MARGINAL 2 ► The output terminal will be energized whenever the Marginal Limit for Sensor 2 has been reached. See alarm notification note above.

MARGINAL 3 ► The output terminal will be energized whenever the Marginal Limit for Sensor 3 has been reached. See alarm notification note above.

MARGINAL ALL ► The output terminal will be energized whenever the Marginal Limit for any sensor has been reached. See alarm notification note above.

O2 TRIM LIMIT ► The output terminal will be energized whenever the O2 Trim Limit has been reached. See alarm notification note above.

HIGH FLUE TEMP ► The output terminal will be energized whenever the O2 Flue Temperature Limit has been reached. See alarm notification note above.

O2 PROBE LIMITS ► The output terminal will be energized whenever any O2 Probe Limit has been reached. See alarm notification note above.

ALL LIMITS ► The output terminal will be energized whenever any O2 Probe Limit or any Sensor Limit has been reached. See alarm notification note above.

VARIABLE FREQUENCY DRIVE

In addition to using a precision servo motor to control the air flow into a combustion chamber, the NXF4000 can control one or two variable frequency drives (VFD/VSD) with the result being better control over air flow and improvements in combustion. Electrical energy savings and additional gains in efficiency are quickly realized when controlling the combustion blower motor with a VFD. To obtain VFD/VSD control, it is necessary to insert a NXCESVFD plug-in daughter board into the NXF4000. The NXCESVFD provides two independent VFD/VSD channels with each channel containing one precision 4-20 mA output for VFD/VSD control, one calibrated 4-20 mA input used to monitor feedback from the VFD/VSD and one encoder input used to count pulses from a directly connected shaft encoder. All inputs and outputs are available through connector P14. Shielded cable should be used to connect VFD inputs and outputs to the NXCESVFD. Refer to installation manual NXCESVFD-1001.

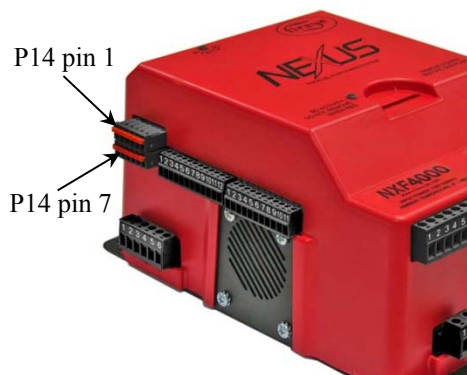

	VFD1			VFD2		
Function	4-20 mA Out [To VFD]	4-20 mA In [From VFD]	Encoder In	4-20 mA Out [To VFD]	4-20 mA In [From VFD]	Encoder In
Signal	P14.6	P14.4	P14.2	P14.5	P14.3	P14.1
Common	P14.12	P14.10	P14.8	P14.11	P14.9	P14.7

Connect shield wires to EARTH post located on NXF4000 chassis.

Alternatively, since the NXCESVFD board supplies a 4-20 mA output, each channel's output can be designated or mapped to output modulation rate, setpoint, sensor value, servo position and combustion parameters derived from the O2 probe. The intent is to provide this output to a chart recorder or some other display device of the user's choice. See ANALOG OUT SETUP submenu.

NXCESVFD SPECIFICATIONS	
VFD OUT:	4-20 mA, Input impedance of external device: Max. 750 ohms
VFD IN:	4-20 mA, Input impedance: 100 ohms
ENCODER IN:	2.4 Kohm pull-up to 24 vdc

Each VFD channel, if selected to be used as a VFD, is treated in the same manner as a servo motor. Each VFD is setup and configured through the SERVO SETUP submenu. After menu configuration the VFD must be commissioned in the profile assigned.

In order to use a VFD output as an indicating device, the VFD channel must not be configured to be used as a servo. Conversely in order for a VFD channel to be available to be used as a servo, its status in the ANALOG OUT SETUP submenu must be set to UNUSED. Shown below is the SERVO SETUP menu after servos have been learned to discover servo 1 and servo 2 and to show that both channels, VFD1 and VFD2, are available to be used to control VFD's. Any VFD channel used otherwise in the ANALOG OUT SETUP menu would not be displayed in the servo setup menu.

<	S	E	R	V	O		S	E	T	U	P									
>	S	E	R	V	O		S	P	E	E	D							3	0	<
	S	E	R	V	O	S		I	N	S	T	A	L	L	E	D				2
	S	E	R	V	O		1													>
	S	E	R	V	O		2													>
	V	F	D				1													>
	V	F	D				2													>



Each VFD channel has its own separate and independent sub menu. The following assumes that VFD2 is moved between the two tick marks and the NEXT key is pressed to display the following configuration menu.

<	V	F	D		2																
>	V	F	D		N	A	M	E									F	A	N		
	A	S	S	I	G	N	M	E	N	T			4	,	3	,	2	,	1		
	D	I	S	P	L	A	Y		F	O	R	M	A	T		E	N	C	O	D	
	E	N	C	O	D	E	R		C	O	U	N	T	S			1	0	0	0	
	R	U	N		M	O	D	E									A	U	T	O	
	G	A	I	N													1	.	0	%	
	I	N	T	E	G	R	A	L										0	.	1	
	T	O	L	E	R	A	N	C	E									H	I	G	H
	A	C	C	E	L	/	D	E	C	E	L							3	0	s	
	S	T	O	P		T	I	M	E									0	s		
	V	F	D		2		P	O	S	I	T	I	O	N						0	

Explanation of VFD parameters:

1. User selects name of VFD. The VFD must be named in order to be usable. The default is UNUSED.
 - a. The list of names available is the same as the list available for servo motors. It is required that at least one of the servos be named AIR and the AIR servo is considered the “master/lead” drive, when a VFD is not used in a profile. If a VFD is used in a profile, the FUEL/GAS/OIL servo becomes the “master/lead” drive. A VFD is never the master/lead drive and the VFD name will not impact this rule.
2. The method for profile assignment for VFD's is the same as for servo motors.
 - a. ASSIGNMENT set to a non-zero value prevents the VFD channel from being used as any-thing but UNUSED in ANALOG OUT SETUP sub menu.
3. DISPLAY FORMAT is used to select the method of feedback used from the VFD. Two methods of feedback can be selected, 4-20 mA or encoder. CNTS and PERCENT FULL SCALE are dependent on 4-20 mA from the VFD. Encoder counts is dependent on the use of an encoder. CNTS is the de-fault and has a range of 0 - 1000 and is derived from the 4-20 mA feedback.%FS translates the 4-20 mA to a scale ranging from 0 - 100.0%. The scale for encoder counts is dependent on the encoder used.
 - a. Total encoder count is determined by the encoder's counts per revolution specification and motor's maximum revolutions per minute, RPM. The allowable range is 300 to 5000 with a default of 1000. The user should refer to the following rule to determine the encoder pulses per second.

$$\frac{\text{Max Motor RPM} * \text{Pulses per Revolution}}{60} = \text{encoder pulses per second}$$

- b. The system will then use this number to scale the counts to a value of 1000. Actual encoder pulses per second can be found in the INFO SCREEN.
4. RUN MODE gives the user the option of using the internal NXF4000 PID (preferred) to control the VFD position or using the internal VFD drive's PID to control the VFD setpoint. The options are AUTO (default) and MANUAL.
5. In AUTO mode, gain and integral terms are used by the VFD plug-in board to control the setpoint of the VFD. The VFD setpoint is the position of the VFD as commanded by the NXF4000. The goal would be to have little difference between the VFD commanded signal (setpoint) and feedback signal.
 - a. Gain is the amplification of the error signal. This error signal is the deviation between feed-back and control. A high gain can result in unstable operation and cause overshoot. The range is 1.0% to 100% with an increment of 0.1% and a default of 1.0%.

- b. Integral is the time between error corrections or updates to the VFD. A high rate of updates (short integral time) to the VFD can result in unstable operation. Conversely too few updates (long integral time) to the VFD can result in large deviations from setpoint. Update time to the VFD output is done at ¼ second intervals. The range of value for INTEGRAL is 0 to 100 in increments of 0.1 with a default of 0.0. The lower the setting, the shorter the integration time will be. The default setting of 0.0 will inhibit integration. A setting of 100.0 will have the longest integration time.



NOTICE: using the default values, the VFD should never overshoot its target. If overshooting is observed, the VFD drive is using its own PID control. If the user wishes to use the VFD's PID control, the user must set the NXF4000's VFD RUN MODE to MANUAL to disable the PID control. Either the VFD Drive or the NXF4000 can use PID control, not both. Before the user attempts commissioning, the PID control of the VFD system must be set properly or the commissioning process will be very difficult and time consuming waiting for the VFD to stabilize.

6. Tolerance is the acceptable error in feedback signal received from the VFD. Feedback signal can be the VFD's analog 4-20 mA of encoder pulses. Both feedback types are normalized to a range of 0 - 1000. Tolerance is expressed in terms of percentage of current feedback reading. A LOW tolerance requires the positioning error to be less than 4% of setpoint over a 30 second period. A HIGH tolerance requires the positioning error be less than 6% of setpoint over a 15 second period. Lockout occurs if the tolerance level is exceeded. Default is HIGH.
7. The ACCEleration / DECEleration time is the time required to move from minimum (0 Hz) to maximum (60 Hz) and from maximum to minimum speeds. The default value is 30 seconds and has a range of 0-255 seconds. With ACCEL and DECEL specified the rate of change of the 4-20 mA output is based on this time. During the accel/decel period, the VFD is allowed to move to its next position and not be checked for errors until the time has expired.
8. Local laws and codes require the air flow switch to be proven open before the start of a cycle, thus the VFD must be nearly stopped before the air flow switch may open. The STOP TIME parameter is the amount of time the NXF4000 will wait between cycles before starting a new cycle, allowing large motors to fully coast to a stop. User can adjust STOP TIME between 0 and 100s, with 1s increments. The default value for STOP TIME is 0 seconds.
9. Shows the current position during a burner cycle, of the VFD in units specified by DISPLAY FOR-MAT. Unlike a servo, the VFD position cannot be adjusted or displayed properly in standby. Manual adjustment of the position is prohibited during a burner cycle.



NOTICE: The ENCODER inputs are safety rated and they must be utilized to meet the requirements of fail-safe operation. An optical encoder or equivalent device must be attached to the shaft of the blower motor and wired to the encoder inputs to provide a fail-safe operation.

ENCODER INPUT

1. The encoder inputs on the NXCESVFD plug-in board are designed to use an encoder that provides an open collector output. The encoder input of the NXCESVFD is a 2.4 Kohm pull-up resistor internally connected to 24 vdc. The encoder selected must be able to handle 10 mA.
2. The NXF4000 tolerates maximum encoder counts over a range of 300 to 5000 counts per second. For a motor with a maximum RPM of 1750, the range of encoder would be 12 to 150 counts per revolution. Likewise for a motor with a maximum RPM of 3600, the range of encoder would be 5 to 80 counts per revolution.
3. Shielded cable should be used to connect the encoder output to the NXCESVFD. The drain wire must be connected to the EARTH post.

Operational Notes:

1. Consult the VFD manual for adapting, connecting and configuring the VFD to the combustion blower motor. Be sure all inputs and outputs are compatible with the NXF4000 and NXCESVFD.



2. The VFD is commissioned like any of the servo motors and must have a position for every setpoint for the commissioned profile.
3. For a VFD channel to be used as a VFD controller, the ANALOG OUT SETUP value for that VFD channel must be set to UNUSED. Only then will the VFD channel be displayed in the servo setup sub menu where the user selects that particular VFD channel and configures it for operation.
4. Making modifications to any of the VFD parameters in the servo setup submenu requires the Commissioning pass code to be enabled.
5. Attempting to change a VFD channel to a value other than UNUSED in the ANALOG OUT sub menu while its ASSIGNMENT > 0 in the SERVO SETUP sub menu is not allowed.
6. Removal of a VFD from the commissioning table (set ASSIGNMENT to 0), will require a re-commissioning without the VFD. That is, lockout will occur if the profile (with the missing VFD) is used during the next burner cycle.
7. A VFD drive normally requires a motor start signal. This is usually derived from a relay energized by the Blower terminal (P4.4) of the NXF4000. The normally open contact is connected to the start input terminal located at the VFD.
8. Using ACCEL/DECEL prevents step changes in the 4-20 mA output signal to the VFD and should be set appropriately. However, adequate values for ACCEL and DECEL should also be set in the VFD to prevent over current conditions.
9. In VFD setup, DISPLAY FORMAT can be set to either CNT or %FS indicating the 4-20 mA feedback from the VFD is being used or can be set to ENCOD which requires an encoder connected to the combustion motor shaft and the maximum encoder counts per second value entered for ENCODER COUNTS. All of these options are scaled and normalized to a range of 0 - 1000. Therefore it is possible after commissioning and operating with one method (CNTS), the user can change the VFD setup to an alternate method (ENCOD). The system will treat this change transparently and attempt to control with this new setting. As long as the ENCODER COUNTS value entered is correct or the 4-20 mA is representing full range frequency, the change should be transparent. However, it is strongly recommended DISPLAY FORMAT be changed only if a complete commissioning or adjust ratio procedure is executed immediately after the change and for all profiles using the VFD.

Performance notes:

1. When controlling a VFD, setting GAIN and INTEGRAL to incorrect values can cause unstable operation of the VFD and subsequently large variations in the combustion blower motor rotation. When setting GAIN and INTEGRAL, the following is suggested:
 - a. Make certain that the VFD drive is not using its own PID.
 - b. Set the NXF4000's VFD RUN MODE to AUTO, and begin with the INTEGRAL set 0.0 and the GAIN is set to 1%.
 - c. The GAIN and INTEGRAL settings can only be verified by observing the system's reaction to a step input. The best way to get a step response is by entering the Commissioning Mode and cycling between p00 and p01 settings. At p00, the VFD is set to 0Hz. Proceed to p01 by pressing the NEXT key, after entering the Commissioning Mode, and setting the VFD target speed to at least 50% if DISPLAY FORMAT is set to %FS or a count of 500 if it is set to CNTS. Note that the BURNER ON/OFF must also be set to ON and there must be a call for heat to go to p01. To go back to 0Hz, press the BURNER ON/OFF button so that it is OFF. Alternately pressing the BURNER ON/OFF will cycle to unit between p00 and p01 positions.
 - d. Increase the GAIN until the VFD begins to oscillate after it steps to p01. Once oscillation is achieved, reduce the GAIN setting by 50%. For example, if a setting of 20 causes oscillation after the step, reduce the GAIN to 10 then proceed to step (e). Note that with the INTEGRAL set to 0.0, the VFD may not be able to reach the target speed.
 - e. Increase the INTEGRAL setting until the VFD is able to reach the target speed with no oscillations.



f. The GAIN and INTEGRAL may have to be adjusted several times to achieve the right balance of reaction time and oscillation but following the above method will get the settings close.

A steady reading is defined as only the tenths digit changing or the combustion blower motor is not hunting.

COMMISSIONING WITH VFD

The VFD is commissioned like any servo motor and must have a position for every profile setpoint for the commissioned profile.

<	C	O	M	M	I	S	S	I	O	N	I	N	G				p	0	3	
>	A	I	R	(1)											2	0	.	6
	G	A	S	(2)											1	3	.	4
	V	F	D		2													6	5	3

The VFD can be commissioned during the initial commissioning process or added to the current commissioning profile. The value shown for VFD in the servo setup table is based on the feedback received from the VFD. During COMMISSIONING and ADJUST RATIO, with MDFY on, this value is the commanded position.

ANALOG OUT SETUP

This menu is found in the top layer and is used to map various signal values to 1 of 3 available 4-20 mA outputs:

	Output	Return
ANA 0 OUT	P11.5	P11.4
VFD 1 OUT	P14.6	P14.12
VFD 2 OUT	P14.4	P14.10

The ANALOG OUTPUT SETUP menu is displayed as follows:

<	A	N	A	L	O	G		O	U	T		S	E	T	U	P				
>	A	N	A		0		O	U	T						U	N	U	S	E	D
	V	F	D		1		O	U	T						U	N	U	S	E	D
	V	F	D		2		O	U	T						U	N	U	S	E	D

Pressing MDFY/SAVE at the > prompt will open the selection menu for items than can be mapped to the selected 4-20 mA analog output channel. Press MDFY/SAVE key again to save selection.

UNUSED	SERVO 1	STACK
MOD RATE	SERVO 2	O2
SETPOINT	SERVO 3	
STBK STPT	SERVO 4	
SENSOR 1	SERVO 5	
SENSOR 2	SERVO 6	
SENSOR 3	SERVO 7	
SENSOR 4	SERVO 8	
SENSOR 5	SERVO 9	
	SERVO 10	

OXYGEN PROBE SETUP

The NXCESO2 oxygen probe provides continuous oxygen (O₂) content and stack temperature readings from the stack. When properly connected and configured to the NXF4000, it allows the NXF4000 to trim the air or fuel servo to achieve optimum combustion. Refer to earlier sections of this bulletin for information regarding installation and wiring of the NXCESO2.



CAUTION: To use oxygen trim properly, the installing personnel must be completely familiar with limitations of the burner / boiler equipment at hand. It is not the purpose of the O₂ probe and associated trim algorithm in the NXF4000 to extend the burner/boiler to operate beyond its design limitations. The purpose of O₂ trim is to maintain a consistent fuel/air ratio through variations in temperature, humidity and fuel BTU content. When properly setup according to these instructions, O₂ trim will result in more heat output per BTU input and increased combustion efficiency and fuel savings will be realized. It is expected the installing personnel read and understand the O₂ SETUP menu items and commission the O₂ probe in accordance with this bulletin.

To add O₂ trim to the NXF4000 operation the NXCESO2 oxygen probe must be commissioned with the air and fuel servos. Commissioning with O₂ can be done after the servos are commissioned or can be done along with the initial servo commissioning. During the commissioning process the NXF4000 will save the target O₂ level at each profile setpoint. During normal operation the NXF4000 will trim either the air or fuel servo to maintain this established O₂ target level. O₂ trim occurs from low fire (p03) through high fire (pHigh). O₂ trim will take effect only after all profile setpoints are commissioned with an O₂ level. If O₂ trim is enabled through the user interface and the system has yet to be commissioned to set the O₂ levels, then O₂ trim will be ignored.

The NXF4000 provides an extensive sub menu where the installing engineer must set a number of key boiler parameters relating to O₂ trim operation. The O₂ SETUP is passcode protected. All parameters in the O₂ SETUP menu are readable but do require at least the Adjust Ratio passcode to be enabled before any parameter can be modified. The passcode will remain enabled for 5 minutes after the last key press. Any change to the O₂ SETUP menu will take effect immediately.

In the top layer menu scroll to O₂ SETUP and press NEXT to enter this sub menu. This menu provides the means to enter all O₂ parameters relating to trim. If not enabled, when pressing the MDFY key, the user will be diverted to the passcode screen where at least the Adjust ratio code must be entered.

Most menu items are burner / boiler dependent and it is important the installing / commissioning engineer be familiar with the burner / boiler to understand its capabilities and limitations.

Menu item	Value	Description
O ₂ OPERATION	DISABLED	O ₂ trim is not enabled. No further menu items are displayed.
	CONTROL	O ₂ trim enabled for profiles selected. All menu items are displayed. The O ₂ level is shown in the top layer.
	MONITOR	Allows O ₂ level to monitored with trim being disabled, but the O ₂ level is shown in the top layer.
CALIBRATE	NOW>	When the NEXT key is pressed a calibrate signal is sent to the NXCESO2 probe. The function is operational only during STANDBY and PURGE.
ASSIGNMENT	4,3,2,1	User selects which profile O ₂ trim is applied.
FUEL TYPE (X)	NONE	FUEL TYPE for each assigned profile is required to calculate boiler efficiency. The fuel type selected determines the constants used. Default is NONE.
	NAT.GAS	
	OIL #2	
	OIL #6	
	LNG	
	COKE	
	METHANE	
PROPANE		



Menu item	Value	Description
HEAT LOSS	0.0%	Used to calculate boiler efficiency. Percentage of boiler output lost through the shell of the boiler at high fire. The default is 0% and ranges to 9.9% in 0.1% increment. The NXF4000 will calculate the heat loss at all firing rates and is dependent on burner turndown ratio.
TURNDOWN RATIO	3	Used to determine amount of heat loss at all firing rate positions. Calculated value is subtracted from gross efficiency. Default is 3 with a range of 1 to 10 and an increment of 1. A value of 1 will result in a constant heat loss across all firing rate values.
TRANSPORT DELAY	0s	The range is 0 to 60s. The default is 0s. This is the amount of time it takes for a step change in O ₂ to be realized after a step change of air/fuel is made. Transport delay value should be calculated or derived at lowest air velocity (Low Fire)
TRIM TYPE	AIR	Default selection is AIR trim. As trimming the FUEL servo is more sensitive than trimming the AIR servo, the user should be cautious when selecting FUEL trim.
	FUEL	
TRIM LIMIT RATIO	1	Trim limit ratio is used in determining trim limit. The range of value is 1 to 8 with the default value being 1. See section titled SETTING TRIM LIMITS.
TRIM LIMIT	DEFAULT	Applies to degrees of trim at low fire. Selecting DEFAULT will implement a trim limit of 0.1 degrees at low fire. MANUAL allows users to enter trim limit at low fire for each profile assigned. See section titled SETTING TRIM LIMITS.
	MANUAL	
TRIM LIMIT (X)	2.0 deg	Parameter shown if TRIM LIMIT is set to MANUAL. The term (X) refers to profile assignment. The range of trim limit allowed is 0.1 to 3 degrees in 0.1 degree increments. See section titled SETTING TRIM LIMITS.
TRIM P-GAIN (X)	6%	Sets the proportional gain term. The higher the gain term is, the more aggressive the O ₂ trim. The range of value is 0 to 100% where 100% is maximum gain. Care should be used when selecting this term.
TRIM I-GAIN (X)	95	Sets the integral gain term and is the amount of error signal being fed back. The maximum value is 100% and a faster rate of integration (resets per minute) is realized. The range is 0- to 100%.
O2 FAULT ALM	WARNING	Default value is WARNING and pertains to faults detected in the O ₂ probe. WARNING will disable O ₂ trim and burner operation will default to commissioned air and fuel servo settings. A LOCKOUT selection will cause burner shutdown with the lockout message recorded to fault history.
	LOCKOUT	
O2 LEVEL ALM	UNUSED	Action that takes place if programmed O ₂ levels are exceeded. UNUSED is no action taken. WARNING is alarm energized, burner remains on line. LOCKOUT results in burner shutdown and message recorded to fault history.
	WARNING	
	LOCKOUT	



Menu item	Value	Description
O2 LO ALM@LO (X)	0.5%	LO refers to O2 level alarm limits below the O2 curve. HI refers to O2 level alarm limits above the O2 curve. The values entered are the deviation from the current target value. The default value is 0.5% O2 deviation and the range of values is 0.1% to 5.0% in 0.1% increment. Enter values for each curve for low fire and high fire. The NXF4000 interpolates the alarm value between these points. See section titled GENERAL RULES FOR ALARM NOTIFICATION.
O2 LO ALM@HI (X)		
O2 HI ALM@LO (X)		
O2 HI ALM@HI (X)		
FLUE TEMP ALM	UNUSED	Action that takes place if programmed flue temp levels are exceeded. UNUSED is no action taken. WARNING is alarm energized, burner remains on line.
	WARNING	
FLUE TEMP LO (X)	40F	Range of value is 40F (4C) to 800F (426C). The values represent the low limit and high limit to define the acceptance zone. The NXF4000 interpolates the alarm value between these points.
FLUE TEMP HI (X)	40F	
FLUE LO TIME	0 min	Enables a Low Fire Hold time when the flue temperature, as reported by the oxygen probe, is below the user setting specified in FLUE TEMP LO. Set to 0 to disable.

SETTING TRIM LIMITS

O2 trim limits (expressed in degrees) are derived from trim limit ratio, trim limit at low fire (p3) and the current firing rate of the burner. Care should be exercised when selecting these values. The trim limit applies to both clockwise and counter-clockwise directions and is a deviation from the commissioned position. The expression to determine trim limits is as follows:

$$\text{Allowable Trim Limit} = T_0 \left((R_{TD} - 1) \left(\frac{M_p}{100} \right) + 1 \right)$$

Where:

R_{TD} = user specified trim limit ratio ($R_{TD} > 1$)

M_p = present firing rate of burner (0 to 100%)

T_0 = user specified trim limit at low fire (0% firing rate)

A large trim limit ratio will yield a large value of trim limit at the high fire position. Care must be exercised when selecting these values.

A trim limit ratio of 1 will yield a constant trim limit from p03 to pHigh.

It is of absolute importance to realize that trim limit applies to both clockwise and counter-clockwise direction from the commissioned or untrimmed servo position. The trim limit values must be selected as to not reach the mechanical stop at either end of the trimmed servo travel. See section relating to operating with O2 trim.

There is typically a 10:1 ratio between air and fuel in any combustion system and therefore if selecting fuel as the trimming servo, trim limits should be selected so as to allow only sufficient movement to achieve the desired target.

At lower firing rates, a small movement of the servo is required to cause a significant change in the air/fuel ratio as compared to high fire.



CAUTION: It is the responsibility of the installing and operating personnel to ensure the trim limits selected do not allow a hazardous combustion condition to occur. In the event of an O₂ probe failure the untrimmed commissioned servo setpoints will be used.

Trim limit ratio = 3 Trim Limit = 2 degrees	
Firing rate%	Trim limit Degrees
0	2.0
10	2.4
20	2.8
30	3.2
40	3.6
50	4.0
60	4.4
70	4.8
80	5.2
90	5.6
100	6.0

Trim limit ratio = 3 Trim Limit = 3 degrees	
Firing rate%	Trim limit Degrees
0	3.0
10	3.6
20	4.2
30	4.8
40	5.4
50	6.0
60	6.6
70	7.2
80	7.8
90	8.4
100	9.0

Trim limit ratio = 4 Trim Limit = 3 degrees	
Firing rate%	Trim limit Degrees
0	3.0
10	3.9
20	4.8
30	5.7
40	6.6
50	7.5
60	8.4
70	9.3
80	10.2
90	11.1
100	12.0

As can be seen from the above the trim limit is a progressively increasing number from low fire to high fire. The following illustrates the trim limits from the above tables:

FIGURE 7. Effect of Trim Limit Ratio on Trim Limits

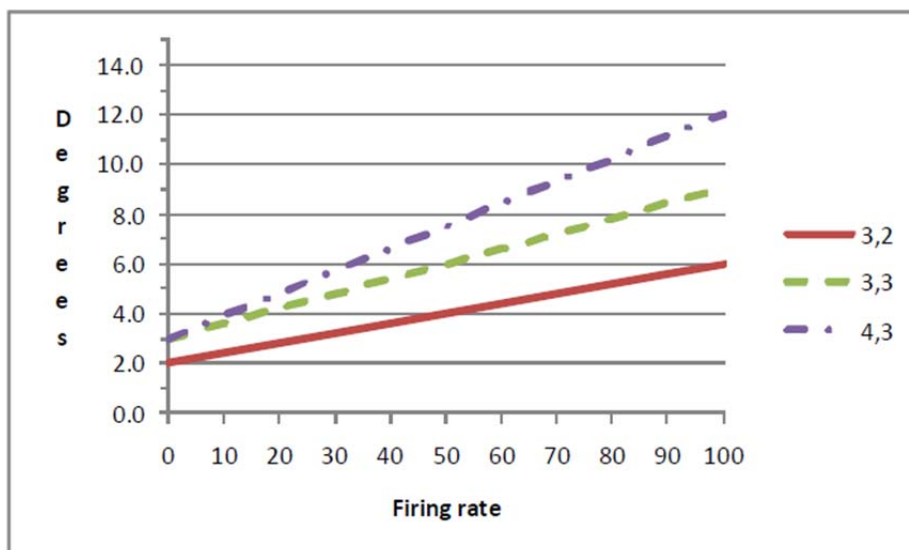

GENERAL RULES FOR O₂ ALARM NOTIFICATION

The values entered represent the deviation from the current O₂ target value. LO alarm refers to O₂ levels under the O₂ curve. HI alarm values refer to values above the O₂ curve. The acceptable zone lies between the LO curve and the HI curve. The following chart illustrates the HI and LO settings for above and below the O₂ curve.

FIGURE 8. O₂ Level Alarm Limits

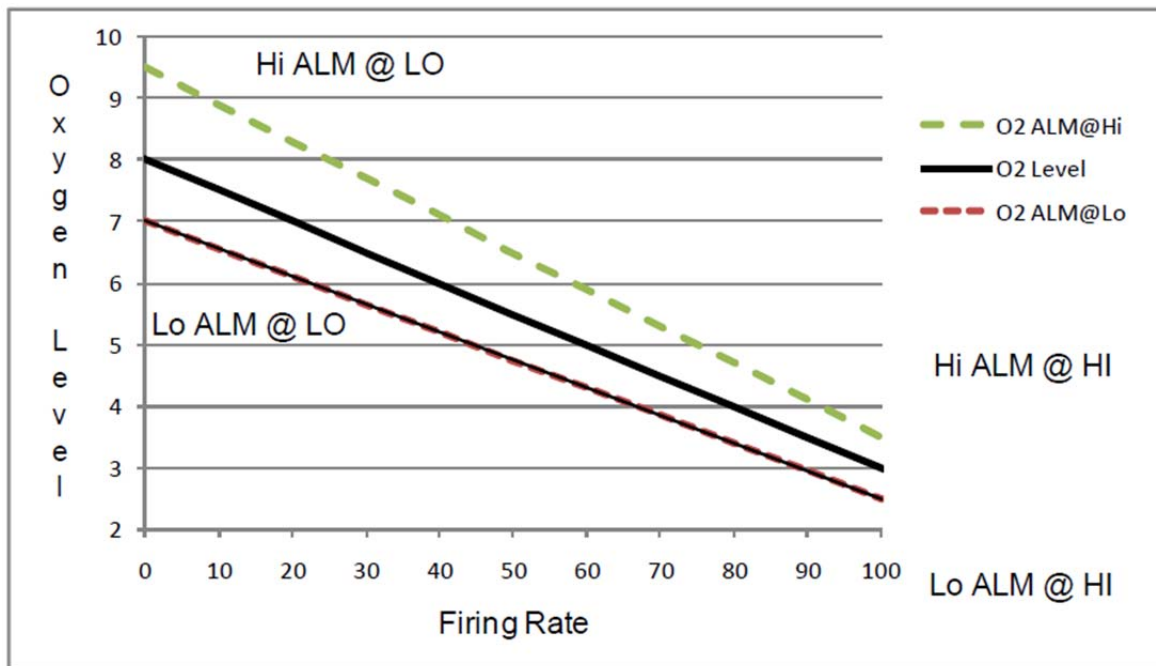

Each profile will have its own set of alarm level values. The alarm value for each succeeding profile setpoint is interpolated from these inputs.

Rules for alarm notification:

- The O₂ level drops below the absolute value of 0.5% O₂ for 30 seconds.
- The O₂ level drops below the low alarm limit for 2 minutes.
- The O₂ levels drops below twice the low alarm level for 30 seconds.
- The O₂ level rises above the high alarm limit for 2 minutes.
- The O₂ level rises above twice the high alarm limit of 30 seconds.

Note: The O₂ level alarm timer is reset to 0 when the actual O₂ level returns to within the acceptable zone.

FLUE TEMPERATURE ALARM LIMITS

The NXF4000 provides flue temperature limits for each profile. Available is the option to activate flue temperature limits as warning. In warning mode, a message will be posted to the display and alarm relay will be energized

To use flue temperature alarm the user must enter the low limit flue temperature and high limit flue temperature. When the burner is firing the flue temperature must remain in the acceptance zone defined by these two limits as shown in the following chart:

FIGURE 9. Flue Temperature Limits

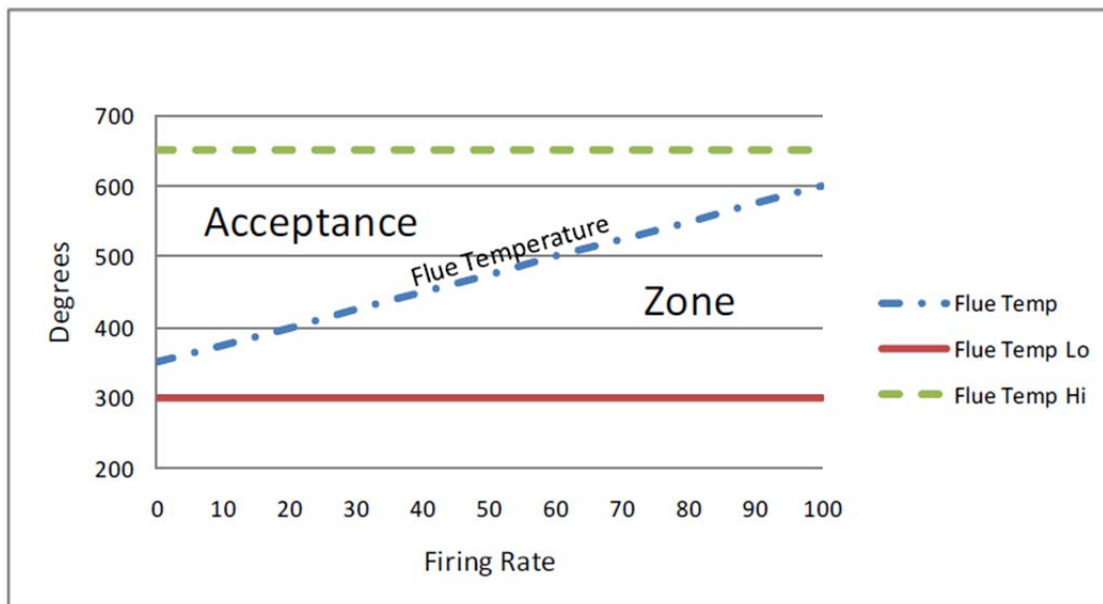

Note: The NXF4000 requires the flue temperature to be above the high limit or below the low limit for 30 seconds before action takes place.

GAIN TERMS

O2 trim is performed using the current O2 level, the current saved target value and the boiler transport delay. These terms are used in a PID algorithm to determine the amount of servo trim to be applied.

1. P-GAIN is proportional gain and is the fractional part ranging from 0 to 1 (unity). Through the user interface P-GAIN is expressed as 0 to 100%. The default value of P-GAIN is 6% or approximately 1/16. Increasing values of P-GAIN add amplification to the O2 trim and make the responsiveness more aggressive. Caution should be exercised when selecting P-GAIN as overshoot of the target could occur.
2. I-GAIN is integral gain and defined as the reciprocal of Ti value in seconds ranging from 1 to 100 (subtracted from 101). The default value of 95 is 1/6 seconds. Selecting a value of 100 forces the fastest possible integration time of 1 second. A value of 0 is a special case and disables the integrator. A lower value of integration will slow down calculations and add time to reach the target value.
3. BOILER TRANSPORT DELAY can be defined as the derivative term when determining the amount of servo trim to be applied. Any spikes or rapid changes in O2 levels caused by any disturbances will be filtered by the boiler transport delay term and prevent large changes in trim to be applied. The default for boiler transport delay is 0 seconds and it is recommended this not be changed if the O2 readings are relatively steady.

UNDERSTANDING O2 ERROR CODES

Upon detection of an error condition (lockout or warning) relating to the O2 probe the NXF4000 will post to the display a singular message 'O2 FAULT eXX' on the HOME screen in place of the status message. In the event of a lockout condition resulting from O2 levels being exceeded, flue temperature levels being exceeded or a fault in the O2 probe, the NXF4000 will revert to the FAULT HISTORY menu with the details of the lockout described. For both lockout and warning events, the alarm relay will be energized. Lockouts are non-volatile and require a manual reset. Warnings are dynamic and will self-remove when the condition causing the warning no longer exists.

The message O2 FAULT eXX contains the error message causing the lockout or warning event. The error message 'eXX' is described in the following table:



Table 3:

e-code	VALUE	DESCRIPTION
44	BAD VECTOR	Incorrect communications with O2 probe
45	RETURN BOUNDS	
46	BAD ERROR CODE	
47	COMMUNICATION ERROR	Check wire, routing and connections to O2 probe
48	LOW LEVEL O2 LIMIT	O2 level exceeded limits set in O2 setup menu
49	HIGH LEVEL O2 LIMIT	
50	O2 LOW STACK TEMP LEVEL	Flue temperature exceeded limits set in O2 setup menu
51	O2 HIGH STACK TEMP LEVEL	
52	RESERVED	
53	RESERVED	
54	STACK TEMP PROBE DISCONNECTED	Hardware fault in probe
55	STACK TEMP OVER RANGE	Temp probe has exceeded its maximum range, 900F (482C)
56	STACK TEMP READ ERROR	Hardware fault in probe
57	AMBIENT TEMP READ ERROR	Hardware fault in probe
58	AMBIENT TEMP OVER LIMIT	Temperature in probe has exceeded 185F (85C)– check fan
59	AMBIENT TEMP UNDER LIMIT	Temperature in probe is lower than -13F (-25C)
60	CPU CRC ERROR	Hardware fault in probe
61	CPU RAM ERROR	
62	CPU SELF TEST	
63	24 VOLT LOW FAULT	Voltage in probe not within 18-30 vdc limits
64	24 VOLT HIGH FAULT	
65	12 VOLT OPEN FAULT	Voltage regulator in probe out of acceptable tolerance
66	12_VOLT_LOW_FAULT	
67	12 VOLT HIGH FAULT	
68	UNEXPECTED CALIBRATION FAULT	Illegal self-calibration perform
69	SENSOR O2 STUCK FAULT	O2 sensor not responding properly
70	SENSOR CALIBRATION NEEDED	O2 sensor subsystem cannot perform measurement
71	SENSOR HEATER SHORT FAULT	O2 heater fault
72	SENSOR HEATER OPEN FAULT	
73	SENSOR PUMP SHORT FAULT	O2 pump fault
74	SENSOR PUMP OPEN FAULT	
75	SENSOR CELL SHORT FAULT	O2 sensor fault
76	SENSOR CELL OPEN FAULT	
77	SENSOR CONVERSION TIMEOUT FAULT	O2 sensor taking too long to convert O2 level
78	SENSOR LOW VOLTAGE FAULT	O2 voltage level too low
79	SENSOR TOO COLD FAULT	O2 sensor heater temperature out of tolerance
80	SENSOR TOO HOT FAULT	
81	SENSOR AIR CALIBRATING	Sensor calibration in progress
82	SENSOR HEATER CALIBRATING	Heater calibration in progress
83	SENSOR COMM BUSY	
84	SENSOR COMM FAULT	Hardware fault in probe
85	SENSOR WARMING_UP	Sensor warming after power on
86	SENSOR IN STANDBY	O2 probe forced to standby condition

COMMISSIONING PROCEDURE:

NOTICE: It is the purpose of this bulletin to explain the operation of the NXF4000 control and the NXD410 User Interface along with required FX servo motors and pressure/temperature transducers. The servo motors control the air and fuel on the burner independently in accordance with the commissioned information. Being there are an infinite number of burner sizes and types, it is beyond the scope of this bulletin to show in absolute terms the proper combustion operation of the burner on which the equipment is installed. This bulletin is a detailed guide on how to properly setup the NXF4000 and associated equipment to achieve maximum efficiency. It is the responsibility of the commissioning personnel to know the capabilities and limitations of the burner/boiler. This would include the turn down ratio, ignition setting, low fire setting and high fire setting, and proper O₂ levels at each firing point along the curve. It is expected the commissioning or operating personnel be sufficiently trained by the burner OEM to know the do's and don'ts of their particular burner and to have relevant experience in the theories and practices of combustion control. Fireye cannot accept any liability for any consequences resulting from inappropriate, negligent or incorrect installation, commissioning or adjustment of operating parameters of the equipment.



WARNING: If a LOCKOUT occurs at any point the NXF4000 will not attempt a re-start until the fault is cleared, unless the option to allow recycling is enabled. Before moving to the ignition position to attempt a re-start the system must perform any selected pre-purge.

Ensure that a purge position is entered for each drive as required. Failure to enter a purge position will mean all drives remain at their 'closed' positions.

After entering and/or adjusting any profile points for any profile it is the responsibility of the commissioning personnel to verify that the resulting fuel air ratio is acceptable for the appliance being controlled.

A profile is a set of points defining the servo motor positions along the burner's operating curve. The operating curve begins at standby (P00), extends through purge (P01), ignition light-off (P02) and up through the modulation firing rate (P03 to P23).

PROFILE SETPOINTS

Setpoints contain information about required motor positions. There must be at least one servo motor named as AIR in each profile. There are four profiles (or tables) of setpoints available in the NXF4000 control. The profiles may be represented using the diagram below:

Gas position (degrees)	Air Position (degrees)		Oil Position (degrees)	Air Position (degrees)
2.1°	1.9°	Close (P00)	1.7°	1.9°
2.1°	87.9°	Purge (P01)	1.7°	87.9°
24.6°	30.6°	Ignition (P02)	10.6°	28.7°
21.3°	25.8°	Low Fire (P03)	10.6°	28.7°
76.8°	85.6°	High Fire (Pxx)	50.2°	83.5°



COMMISSIONING RULES

1. Commissioning mode is used for entering new setpoints in a profile.
2. Existing setpoints can be modified in commission mode or adjust ratio mode.
3. Only commissioning mode can be used to modify setpoints P00, P01 and P02.
4. Setpoints P03 and higher will not be affected when C-MODE is exited at P02 or lower.
5. There are 24 possible positional setpoints per profile, number P00 to P23. P00, P01 and P02 are reserved for closed (standby), purge and ignition. Positions P03 through P23 traverse the burner's firing rate where P03 is always low fire. The last point entered is always considered high fire and will correspond to 100% modulation rate.
6. Using commission ratio mode, it is possible to step through each setpoint including close, purge and ignition.
7. Once a setpoint has been entered, it is not possible to go back and modify it again in the same commissioning session. That is, the BACK key is not usable in commissioning mode.
8. During commissioning mode if a controlled shutdown or lockout occurs, the current commissioning data will not be lost. The control will revert back to P00, also known as the closed position. After the shutdown condition is cleared, burner startup can once again resume using the new commissioned data prior to the shutdown.
9. For a system to operate, the minimum setpoints that must be entered are P00 through P03.
10. It is recommended that all servo positions commissioned by the user be between 3° degrees and 97° degrees.
11. The master servo (AIR/FUEL) must be commissioned in such a way that the current commissioning point must be at least 0.1 degree greater than the prior point. This rule applies to commissioning points greater than P03 (low fire). A violation of this rule will prevent the user from moving to the next commissioning point or exiting commissioning.
12. If a user is modifying any servo position (MDFY indicator is on) and then decide to access the INFO screen, the modify operation is automatically cancelled and whatever position that was entered prior to going to the INFO screen will be lost. The servo position will be reverted to the last successfully saved commissioned point
13. System must maintain “call for heat” for successfully commissioning. Make sure the inputs and states are valid for applicable sensors, digital inputs, recycle and non-recycle inputs.

Entering commissioning mode:

To enter commissioning mode, the burner must be off and the user presses the C-MODE key located on the keypad. If not currently enabled, the system directs the user to the passcode setup screen where the user must enter the necessary commissioning passcode. If entered properly or if previously entered the LED indicator at the C-MODE key will illuminate and the display will indicate:

<	C	O	M	M	I	S	I	O	N	I	N	G					p	0	0	
>	S	T	A	N	D	B	Y										s	0	1	<
	B	U	R	N	E	R		O	F	F										
	A	I	R	(1)											3	.	1	°
	G	A	S	(3)											1	.	9	°
	O	I	L	(2)											2	.	6	°

It is usual to have no profile selected while in P00. Therefore all installed and named servos are shown as displayed above along with their current position. If a profile is selected while in P00, then only the servos pertaining to that profile are displayed.

If a control was previously commissioned then the currently stored profile will be loaded and be used as the base setpoints. Note: this can only occur when a profile is actually selected. If not commissioned (out of the box condition) then the succeeding Pxx point should be the same as the preceding Pxx point. For example, when moving from P02 to P03, P03 assumes the same values as P02.

The NEXT key is used to move to the next setpoint, P01, P02, etc.



CAUTION: The assumption is the user has completed the initial setup procedure, configuring sensors and learning and mapping servos. If setpoint information is not entered the user can at least commission P00 but cannot move to P01. If servos are not learned and mapped to a profile, or only one servo is learned and mapped to a profile, even if that profile is not going to be used, then C-MODE cannot be entered. The User Interface will display and flash continuously the message INVALID OPERATION. The user can press the HOME or C-MODE key to exit commissioning to fix the problem.

For illustrative purposes the shaded line represents the > < characters on the keypad and the AIR servo shown below is selected for modifications.

C	O	M	M	I	S	S	I	O	N	I	N	G					p	0	0		
>	A	I	R	(1)											3	.	1	°	<
	G	A	S	(3)											1	.	9	°	
	O	I	L	(2)											2	.	6	°	

To move a servo press the MDFY key and use the UP and DOWN keys to select the target position.

C	O	M	M	I	S	S	I	O	N	I	N	G					p	0	0		
>	A	I	R	(1)											8	.	4	°	<
	G	A	S	(3)											1	.	9	°	
	O	I	L	(2)											2	.	6	°	

When done, the user presses the SAVE key to direct the system to move the servo to the target position. After the SAVE key is pressed the value on the line showing the servo being modified will change back to the current position. This value will be changing as the servo moves to the new target position.

C	O	M	M	I	S	S	I	O	N	I	N	G					p	0	0		
>	A	I	R	(1)											3	.	1	°	<
	G	A	S	(3)											1	.	9	°	
	O	I	L	(2)											2	.	6	°	

C	O	M	M	I	S	S	I	O	N	I	N	G					p	0	0		
>	A	I	R	(1)											5	.	2	°	<
	G	A	S	(3)											1	.	9	°	
	O	I	L	(2)											2	.	6	°	

C	O	M	M	I	S	S	I	O	N	I	N	G					p	0	0		
>	A	I	R	(1)											8	.	4	°	<
	G	A	S	(3)											1	.	9	°	
	O	I	L	(2)											2	.	6	°	

Repeat as necessary for the GAS and OIL servo. The NEXT key is used to move to the next profile setpoint, P01, P02, etc.

Moving from P00 to P01 may prove difficult if no profile is selected, the burner is OFF, or the recycle limit is open. The display may indicate as follows:

C	O	M	M	I	S	S	I	O	N	I	N	G					p	0	0		
>	S	T	A	N	D	B	Y										s	0	1		<
	B	U	R	N	E	R		O	F	F											
	N	O		C	A	L	L		F	O	R		H	E	A	T					



P00 is considered the CLOSED position to which the servos will move to when the burner is off, STANDBY or in lockout. When the user has finished setting the P00 position for all servos, P00 is complete and the user will press the NEXT key to set up P01. At this point, the following conditions must be satisfied in order for the control to successfully proceed to P01 position -

- a. A single profile is valid (Connector P15.5 thru P15.8).
- b. The recycle limit is closed (Connector P15.4).
- c. The Burner ON/OFF button on keypad and/or configured digital input is valid.
- d. The CUT-IN condition for setpoint has been satisfied.
- e. No pending alarm or lockout.

If the above conditions are satisfied, the NXF4000 controller will enter the purge position P01 and wait for the user to set the AIR servo and/or VFD positions. The display may indicate as follows:

C	O	M	M	I	S	S	I	O	N	I	N	G					p	0	1		
>	M	O	V	E		T	O		P	U	R	G	E					s	0	7	<
	W	A	I	T													2	:	0	5	
	A	I	R	(1)											3	.	1	°	
	G	A	S	(3)											1	.	9	°	

Position P01 is the purge position. If previously set the servos will move to their previously programmed positions and stop. With the UP and DOWN keys, the user moves the servo to be positioned into the shaded area and presses the MDFY key. The UP and DOWN keys are then used to select the new target position. The displayed value responds to the UP and DOWN keys. When the new target position is selected, the user presses the SAVE key to retain the settings and the selected servo will move to the new position.

When satisfied with all servo positions the user presses the NEXT key to begin the pre-purge timer. During the purge period the servo positions are inhibited from being moved.

Once pre-purge is completed (30 seconds typically) the NXF4000 will move to its ignition position, P02. The display will indicate:

C	O	M	M	I	S	S	I	O	N	I	N	G					p	0	2		
>	M	O	V	E		T	O		P	U	R	G	E					s	0	9	<
	W	A	I	T													0	:	0	0	
	A	I	R	(1)											8	7	.	5	°
	G	A	S	(3)											1	.	9	°	

If previously set, during the low fire start position the servos will move from their pre-purge position to their ignition or light-off positions and stop. Otherwise, the user moves the servo to be positioned into the shaded area and follows the procedure using the UP, DOWN and MDFY/SAVE keys to properly position the servos and save this data. The display may look like the following:

C	O	M	M	I	S	S	S	I	O	N	I	N	G					p	0	2		
>	A	I	R	(1)												7	.	5	°	<
	G	A	S	(3)												5	.	4	°	
	M	O	V	E		T	O		P	U	R	G	E						s	0	9	
	W	A	I	T														0	:	0	0	

When all servos are at the desired ignition light-off position, the user presses the NEXT key and the NXF4000 automatically sequences through PTFI and MTFI to AUTO using the established PTFI and MTFI timing information in the BURNER CTRL SETUP menu.



NOTICE: Since it is easily assumed the first 'guess' at the ignition positions will not provide a satisfactory light-off, it would be suggested to place the NXF4000 in the CHECK position during PTFI state to allow adjustment of the above servo positions to get the optimum light-off firing condition. To adjust the servos, the aforementioned procedure is used. The SAVE key retains the data. See section on how to place the NXF4000 in the CHECK position.

Upon a successful light off, the NXF4000 advances to the P03 position. The following is displayed:

C	O	M	M	I	S	S	I	O	N	I	N	G					p	0	3	
>	A	U	T	O													s	1	6	<
	F	L	A	M	E		S	T	R	E	N	G	T	H				1	0	0
	A	I	R	(1)											7	.	5	°
	G	A	S	(3)											5	.	4	°

Position P03 is defined as the low fire position of the burner and will be displayed as 0% modulation rate. At this point the user can make adjustments to the servos to achieve the correct fuel/air firing ratio.

C	O	M	M	I	S	S	I	O	N	I	N	G					p	0	3		
>	A	I	R	(1)											8	.	2	°	<
	G	A	S	(3)											6	.	3	°	
	A	U	T	O														s	1	6	
	F	L	A	M	E		S	T	R	E	N	G	T	H				1	0	0	

When complete setting the low fire position, the user presses the NEXT key to advance to the next setpoint, P04.

If this is a newly commissioned unit, hitting the NEXT key at P03 moves the display to indicate P04 but with the same servo positions as P03.

C	O	M	M	I	S	S	I	O	N	I	N	G					p	0	4	
>	A	U	T	O													s	1	6	<
	F	L	A	M	E		S	T	R	E	N	G	T	H				1	0	0
	A	I	R	(1)											8	.	2	°
	G	A	S	(3)											6	.	3	°

At each subsequent setpoint position, the user will most likely increase each servo position in order to increase the firing rate of the burner. However, there are instances, although rare, where a particular servo position may need to be less than or equal to the previous or successive point. This is non-monotonic.

NOTICE: At any point during the commissioning process it may be necessary to check the state of other parameters in the system. For example, if the measured value begins to approach the cut-off point, the boiler will shut down and interfere with the commissioning process. To view these parameters press the INFO key and bring up a list of system parameters with their respective values. Pressing the INFO key again will take you right back to the commissioning process.

It will be up to the user as to how many setpoints are entered. As a minimum, P03 must be entered and P23 is the maximum. The more setpoints entered the better the interpolation between each setpoint and the smoother the firing rate curve.

Ending Commissioning Mode:

Pressing the C-MODE key ends the Commissioning Mode and saves all changes to the current profile. The C-MODE LED will be extinguished. **NOTE: Upon configuring the last commissioning point, the user should press the C-MODE key to exit commissioning. DO NOT hit the NEXT key once the last point has been established, as this would force the user to establish a new point before exiting commissioning.** For commissioning mode, the last setpoint displayed (above p03) will become the new high fire (100% modulation) setpoint. All previously entered setpoints above the point when commissioning is ended will be cleared if the user exits commissioning above p02. If the NXF4000 has been commissioned above p03 and the user enters commissioning again but exits before reaching p03, all previous values above p03 will not be cleared.

On exiting commission mode, the passcode will be disabled.

Modulation Rate vs Commissioning Points:

The firing rate curve (a.k.a. modulation rate) is automatically established by the installer during the commissioning process of the burner. Setpoint p03 is the first position in AUTO and corresponds to 0% firing rate of the burner. If the unit is only commissioned to p03 no modulation rate other than 0% is possible. The final commissioned point (at least p04) is always the 100% firing rate position. The modulation rate is based off a linear interpolation from the 0% to 100% master servo positions.

If no VFD is used in the current profile, the AIR servo is selected as the master servo.

If a VFD is selected for use in the active profile the first FUEL servo is the master servo.

Graph 1 depicts a typical air/fuel profile of a burner with 14 commissioned points and no VFD used in the current profile so the AIR actuator is the master. Its p03 position is 12 degrees and the p13 position is 85 degrees. Therefore, the 50% position is $((85-12) \times 50\%) + 12 = 48.5$ degrees. This puts the 50% modulation rate close to the p10 position. The FUEL actuator at the 50% position will be at approximately 30 degrees.

FIGURE 10. Graph 1 (no VFD):

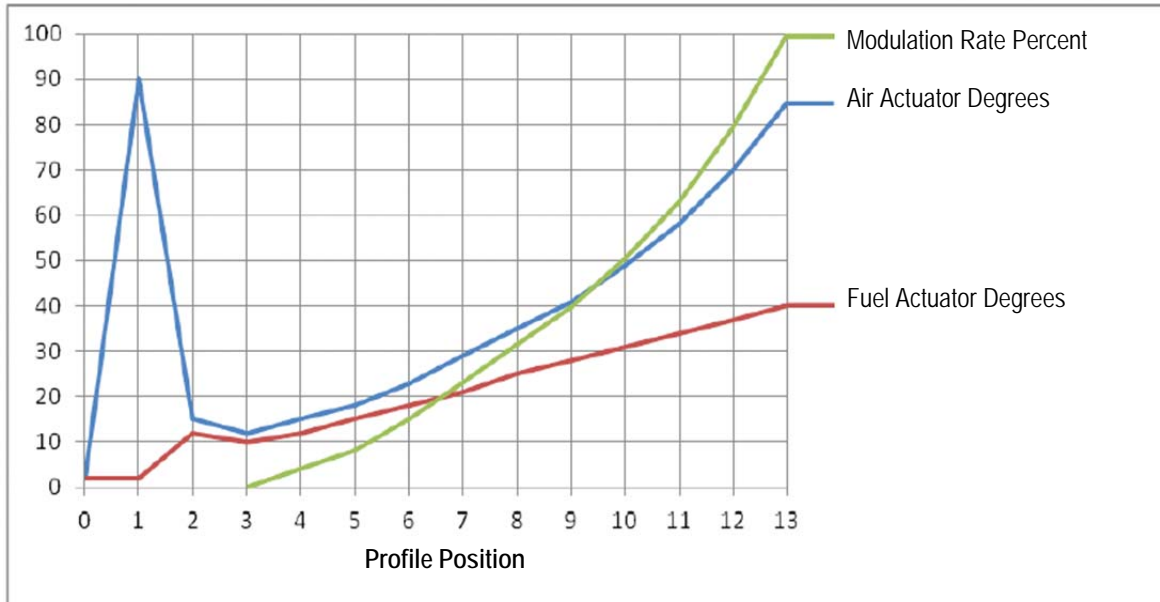

Graph 2 shows the same commissioned actuator positions for both the AIR and FUEL servos as shown graph 1 but with the FUEL actuator used as the master because a VFD is used. Notice how different the modulation curve appears. Because the FUEL's p03 position is 10 degrees and the p13 position is 40 degrees, the 50% position occurs at $((40-10) \times 50\%) + 10 = 25$ degrees. This puts the 50% modulation rate close to the p8 position where the AIR servo is close to 35 degrees.

FIGURE 11. Graph 2 (VFD used):

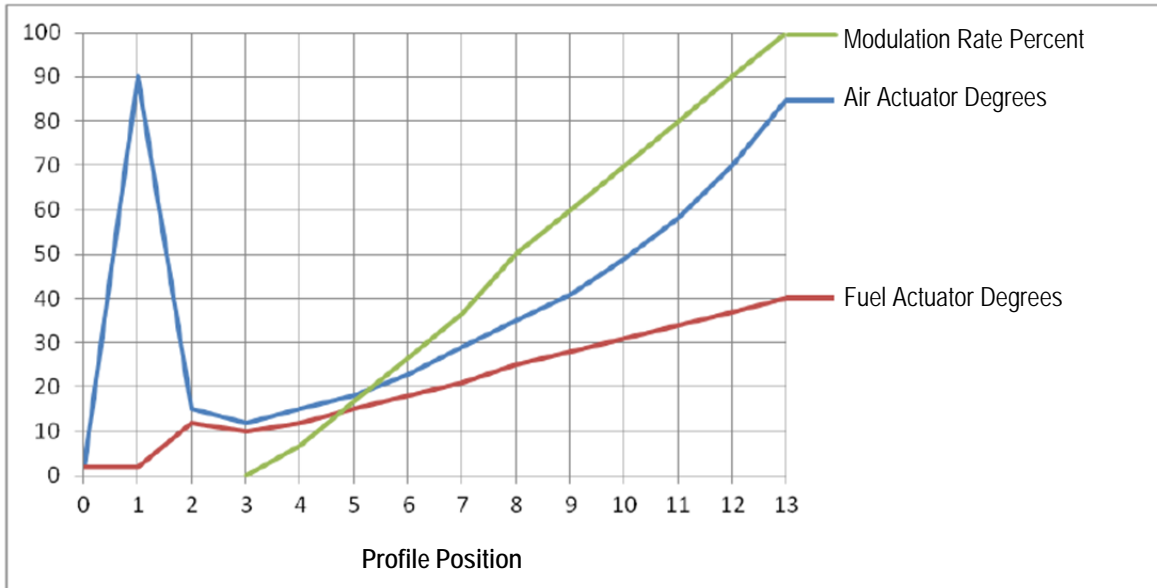

The reason for the difference between the two example curves is due to the AIR servo's steep angle of progression (large slope) but the FUEL servo's has a relative smaller angle of progression (small slope). The modulation rate curve will resemble the curve of master servo.

Selecting manual or automatic modulation rate:

To adjust the modulation rate, the user must first put the NXF4000 into the manual modulation mode. This is done by pressing the AUTO MAN button or by enabling this function through a digital input. Once the manual modulation rate is selected, the display will change from "MODULATION RATE" to "MANUAL MOD RATE". For AUTO modulation:

P	C	V		V	A	L	U	E					8	.	2	p	s	i				
>	M	O	D	U	L	A	T	I	O	N			R	A	T	E		1	0	0	%	<
	A	I	R	(1)								6	9	.	5	°				
	G	A	S	(3)								3	8	.	0	°				

For MANUAL modulation:

P	C	V		V	A	L	U	E					8	.	2	p	s	i				
>	M	A	N	U	A	L		M	O	D			R	A	T	E		1	0	0	%	<
	A	I	R	(1)								6	9	.	5	°				
	G	A	S	(3)								3	8	.	0	°				

To adjust the modulation rate, the user will press MDFY and use the UP and DOWN keys. The modulation will change with the UP and DOWN arrows. When complete the user presses the SAVE key to save the current position.

Only points P00, P01 and P02 can be altered without having any effect on the remaining points in the current profile. This would mean that in commissioning mode, if only P00, P01 and or P02 are changed or revised the remaining setpoints would not be altered if the C-MODE key were pressed to exit.

COMMISSIONING O2 TRIM WITH THE OXYGEN PROBE

Prior to commissioning with the oxygen probe the user must assure the oxygen probe is installed correctly, connected to the NXF4000, communicating with the NXF4000 and the O2 SETUP menu parameters are correctly set, i.e. OPERATION set to CONTROL, etc.



NOTICE: It is important that the O2 Probe is calibrated in the system prior to the commissioning procedure. Failure to calibrate the probe could result in poor O2 trim operation. Consult the O2 probe calibration instruction at the end of this document.

Care should be taken when selecting trim limit ratio and maximum trim limit. The P-GAIN and I-GAIN terms determine the responsiveness of the trim function and are dependent on burner size, fuel type, and transport delay. It is recommended that default values be used to start and adjusted accordingly during system check out.

During commissioning with oxygen and with the O2 OPERATION set to CONTROL, the O2 level and flue temperature currently being measured is displayed with the servo position information.

>	C	O	M	M	I	S	S	I	O	N	I	N	G					p	0	4	<		
	A	U	T	O														s	1	6			
	F	L	A	M	E			S	T	R	E	N	G	T	H				1	0	0		
	A	I	R	(1)												2	7	.	2		
	G	A	S	(3)												1	6	.	3		
	O	2		L	E	V	E	L										6	.	3	8	%	
	F	L	U	E		T	E	M	P										2	8	0	F	

The commissioning procedure previously described is the same with O2 trim.

The O2 trim function requires each profile setpoint from p03 (low fire) to pHigh (high fire) to have an O2 target value associated with that profile setpoint. During the commissioning process the installing personnel must insure the O2 target level is a true representation of the burner operation at that particular setpoint. This is done by waiting sufficient time at each profile setpoint for the O2 level to reach a true and reliable level.



CAUTION: It is the responsibility of the installing and operating personnel to ensure the O2 target levels are within the operating limits of the burner and will not allow a hazardous combustion condition to occur.

At each profile setpoint the target value is saved to interim memory by first using the MDFY key to position the air or fuel servo to their appropriate positions and pressing the SAVE key. After a sufficient wait time to achieve a reliable O2 reading the NEXT key is pressed to save the target value to the setpoint table and move forward to the succeeding profile setpoint.

NOTICE: During commissioning and adjust ratio procedures, O2 trim is not enabled.

Profile setpoint pHigh is saved after waiting sufficient time to achieve a reliable O2 level reading and then pressing the C-MODE key to exit commissioning. Pressing the C-MODE key saves all profile setpoint data to permanent memory and defines the last setpoint entered as the high fire or 100% modulation point.

You cannot manually modify the O2 concentration under the commissioning/adjust ratio screen. A new O2 value is stored when any servo position is modified for the currently selected commissioning point. The O2 value that is stored is the current O2 value at the time that the new position is saved. Make sure the O2 concentration is stable and it is within the expected window before moving on to the next commissioning point. During times that commissioning or adjust ratio needs to be reviewed without affecting the saved O2 target levels, simply pressing the NEXT or BACK key will move to the next or previous setpoint without affecting the saved O2 target level for that previously commissioned profile setpoint.

OPERATION WITH O2 TRIM

With O2 trim enabled, if the firing rate changes by an amount of 30% or more, trim will be inhibited until the following conditions occur:

1. The air servo reaches its destination.
2. O2 below target if direction of travel is low fire to high fire.
3. O2 above target if direction of travel is high fire to low fire.
4. O2 within dead band about target.
5. O2 level stable - stable being steady reading plus/minus 0.2%.
6. Servos stop moving for 20 seconds regardless the O2 level.

The trim servo will never move the maximum range of the trim limit in one adjustment.

Inside the dead band, 0.2%, O2 trimming is inhibited.



NOTICE: Status of O2 trim can be verified by hitting the HOME key and reviewing the top line. If O2 trim is active, the top line should read AUTO(t). If O2 trim is not active, the top line should read AUTO.

Trim Limit Test

To test the setting of the trim limit selected during O2 SETUP, it is suggested the user enter adjust ratio mode (O2 trim becomes disabled), move to each profile setpoint and move the trim servo to its maximum and minimum positions defined by the trim limit for that setpoint. Refer to rule shown in section SETTING TRIM LIMITS. The purpose of this test is to insure that no hazardous conditions (high CO levels) exist at the extreme positions of the trimmed servo. The user should be aware that to move the trimmed servo the MDFY and SAVE keys must be used and by pressing the NEXT or BACK key when done testing with this particular setpoint, the current O2 level will be saved as the target for this profile setpoint. The user should ensure the servos are moved back to their originally commissioned position to get back the original target O2 level before pressing the NEXT or BACK key.

Process Control

A key function of the NXF4000 is to maintain the process control variable setpoint. In the ADJUST SETPOINT menu setting a small value of P-BAND and high value of INTEGRAL could cause large and unnecessary swings in the firing rate and subsequently servo motors. It is during these large swings in firing rate that should be avoided when using O2 trim. The O2 trim algorithm will be constantly chasing the target and if the swings are large enough, be inhibited during these large changes. With good PID control the user should set both P-BAND and INTEGRAL to provide the wanted performance yet avoid large firing rate changes.



ADJUST RATIO PROCEDURE

Adjust ratio is used after the profile has been commissioned and all setpoints have been entered. Adjust ratio mode is used only for modifying an existing profile from low fire (P03 through P23) through high fire. No new setpoints can be entered with adjust ratio.

It is not possible to modify the close (P00), purge (P01) or ignition (P02) positions using adjust ratio mode. All other commissioned setpoints can be modified in any order.

It is not possible to modify any servo or VFD position so that it is higher than the high fire setpoint. It is also not possible to modify a master servo position so that it is higher than the leading adjacent setpoint or lower than the trailing adjacent setpoint.

Entering adjust ratio mode:

To enter adjust ratio mode, the burner may be on or off. The user presses the C-MODE key located on the keypad. If not currently enabled the system directs the user to the passcode setup screen where the user must enter the necessary adjust ratio passcode level 2. If the user enters the commissioning passcode while the burner is on, adjust ratio mode is entered. If entered properly or if previously entered the LED indicator at the C-MODE key will illuminate and the display will indicate:

>	A	D	J	U	S	T		R	A	T	I	O					a	0	0	<	
	S	T	A	N	D	B	Y										s	0	1		
	B	U	R	N	E	R		O	F	F											
	A	I	R	(1)											8	.	2	°	
	G	A	S	(3)											6	.	3	°	

With the control in the burner off (STANDBY) position, a profile must be selected to view all the setpoints for that profile. If no profile is selected, only P00 (shown as a00) will be displayed.

Note: Profile is selected through the action of providing line voltage to one of the dedicated profile inputs or using the keypad/display to force a permanent profile selection in the BURNER CONTROL SETUP menu.

If, while in adjust ratio mode and after burner on command is issued attempting to move to a01, there is no commissioning data for this profile, the display will indicate:

>	<	A	D	J	U	S	T		R	A	T	I	O					a	0	0	<
	N	O	T		C	O	M	M	I	S	S	I	O	N	E	D					

At this point the user can and should exit Adjust Ratio mode. See exiting adjust ratio mode.

If the burner is commanded on and there is no profile selected, the display will indicate:

>	<	A	D	J	U	S	T		R	A	T	I	O					a	0	0	<
	N	O		P	R	O	F	I	L	E		S	E	L	E	C	T	E	D		

If entering adjust ratio mode while the burner is in AUTO (modulating) the displayed setpoint will be the closest setpoint to the actual firing rate of the burner. If the calculated modulation point is between two setpoints, the burner will move to the lower setpoint.



While in adjust ratio mode and in STANDBY, s01, the burner can be made to turn on and will cycle through its normal sequence.

1. During the purge and ignition sequence the user will be able to view all programmed setpoints for that profile. No change to any setpoint can be made when below a03.
2. Upon reaching the AUTO state, s16, the modulation rate or servo positions will move to the point corresponding with the displayed adjust ratio setpoint.
3. Upon reaching AUTO, s16, if the displayed adjust ratio setpoint is a00, a01 or a02, the burner will hold at a03 (low fire). The user has the ability to move through all programmed setpoints, forward or backward, using the NEXT or BACK keys. Pressing the NEXT key will not allow the user to exceed the highest commissioned setpoint.
4. Only setpoints a03 and above can be adjusted, the user can move below a03 but will not be able to make any adjustments.
5. As the user moves through the setpoints the servo positions will also move to track the current setpoint selected. However, if the user moves below a03, the servos will remain at their a03 positions.
6. The user is inhibited from making any servo adjustments prior to the servos reaching the selected setpoint.
7. If a VFD is used in the current profile, an additional check is performed on the FUEL servo only to ensure that there are no non-linear setpoints entered. This means that no setpoint will be allowed that would make the servo movement change direction as the setpoint number is increased from a03 to the maximum setpoint entered. For example, if the user has entered 5.0 for a03, 10.0 for a04, and 15 for a05, if the user was adjusting a04, no value below 5.1 or higher than 14.9 would be allowed for the FUEL servo since the a04 value is bounded by the a03 and a05 values. If a VFD is not used in a profile, the same linearity restriction applies but to the AIR servo only not the FUEL servo.

During adjust ratio mode, the user can adjust each servo for that setpoint by using the MDFY/SAVE key followed by the UP and/or DOWN keys and saved by the MDFY/SAVE key.

During adjust ratio mode, the modulation algorithm is ignored. That is, the firing rate or servo positions will be determined by the selected profile setpoint. This applies to setpoint a03 and above. If the BACK is used to move below a03, the firing rate or servo positions will remain at a03.

While in Adjust Ratio, LOW FIRE and AUTO/MAN keypad states are ignored. The INFO as well as the BURNER ON keys are active during adjust ratio mode.

A burner shutdown will occur if one of the following is present: the current process variable's cut-out is exceeded, the burner on limit switch is opened, the recycle input (P15.4) is opened, the BURNER ON key switch is pressed to cause a burner shutdown, marginal limits are exceeded, or lockout due to the non-recycle limit opening. For all of the above the adjust ratio procedure will remain in effect and revert back to a00.

Exiting Adjust Ratio Mode

1. Pressing the C-MODE key forces all setpoints modified and saved to be transferred or saved to permanent memory for this profile. The C-MODE LED will be extinguished.
2. On exiting adjust ratio mode, the passcode will be disabled.

BOILER EFFICIENCY

With an O2 probe (NXCESO2) installed, the NXF4000 will provide boiler efficiency. Along with the O2 probe it is also necessary to install an inlet air temperature sensor (FXIATS-140) and configured to either sensors 3, 4 or 5. Parameters necessary to calculate boiler efficiency are entered through the O2 SETUP submenu. The NXF4000 uses the current O2 value to determine the current CO2 value.

Conditions required to display boiler efficiency:

1. In the O2 SETUP submenu, O2 OPERATION is configured to operate as MONITOR or CONTROL.
2. FUEL TYPE properly selected.
3. Inlet temperature sensor connected to sensor 3, 4 or 5 and properly configured for selected sensor.
4. Flue temperature is required to calculate efficiency.
5. Efficiency will be shown in AUTO only.
6. Items relating to efficiency are not shown if O2 OPERATION is DISABLED.

Sensor 3, 4 and 5

Sensors 3, 4 and 5 are provided to connect an inlet air temperature to be used for the boiler efficiency calculation. Fireye provides 3 ranges of inlet air temperature: -50°F to 300°F (-45°C to 149°C), -40°F to +140°F (-40°C to 60°C), 32°F to 350°F (0°C to 176°C).

It is the responsibility of the installer to only designate either sensor 3, 4 or sensor 5 as inlet air, setting the others to UNUSED. Access to sensor 3, 4 or 5 configuration can be done under SENSOR SETUP in the top layer menu.

	S	E	N	S	O	R		4																	
>	T	Y	P	E																I	N	L	E	T	<
	R	A	N	G	E					-	4	0		t	o					1	4	0	F		

The values shown represent the maximum value of the sensor range.

COLD START THERMAL SHOCK PROTECTION

Cold Start Thermal Shock Protection is a method to slowly increase the burner firing rate on a cold start to limit mechanical stress due to thermal differences. The NXF4000 offers two methods of thermal shock protection: Low Fire and Segment. After thermal shock is satisfied, THERMAL EXIT satisfied, operation of the boiler is handed over to either setpoint 1 or 2.

While THERMAL SHOCK is active, O2 trim is disabled.

Thermal shock setpoints are accessed from the top layer menu and is indicated by THERMAL SHOCK SETUP >. Press the NEXT key to enter this submenu.

The setpoints associated with THERMAL SHOCK are:

	<	T	H	E	R	M	A	L		S	H	O	C	K		S	E	T	U	P				
>	M	E	T	H	O	D		T	Y	P	E		L	O	W		F	I	R	E				<
		S	E	N	S	O	R		U	S	E	D												1
	2	T	H	E	R	M	A	L		S	T	A	R	T		0	.	5	p	s	i			
	1,2	T	H	E	R	M	A	L		E	X	I	T				1	8	0				F	
	1	M	I	N	.		L	O	W		F	I	R	E							1	0	%	
	2	T	I	M	E	D		O	V	E	R	R	I	D	E		3	0	m	i	n			

METHOD TYPE: user selects UNUSED, LOW FIRE or SEGMENT.

If UNUSED is selected then all menu items below this menu item are not displayed.

Line items marked with 1 are LOW FIRE method.

Line items marked with 2 are SEGMENT method.

The factory default is UNUSED.

SENSOR USED: user selects which sensor to use for thermal shock protection. The options are sensor 1, 2 or 3. The sensor used choices are limited to what sensors are selected as USED in the SENSOR USAGE submenu. The thermal shock algorithm needs to know only the type and range of the sensor. **THERMAL SHOCK SETUP should be accessed only after all sensor and setpoints have been setup.**

LOW FIRE METHOD: This method of cold start thermal shock protection is generally used on Water Tube Boilers. The setpoints associated with this method of thermal shock protection is:

- **THERMAL EXIT** (Thermal Shock Exit Setpoint): The NXF4000 will hold the servo motors at the low fire (LF) position, P03, until the steam pressure (or water temperature) reaches the Thermal Shock Exit Setpoint (**THERMAL EXIT**). Once this steam pressure (or water temperature) is reached, the firing rate motor is positioned according to the modulating control algorithm. The units and range displayed are determined by the sensor type selected.
- **MIN. LOW FIRE** (Low fire minimum): Use this selection to set the servo positions are the calculated firing rate position during the low fire method operation. The range is 0 to 100% and the increments are 1%.

FIGURE 12

Cold Start Thermal Shock Protection – Low Fire Method

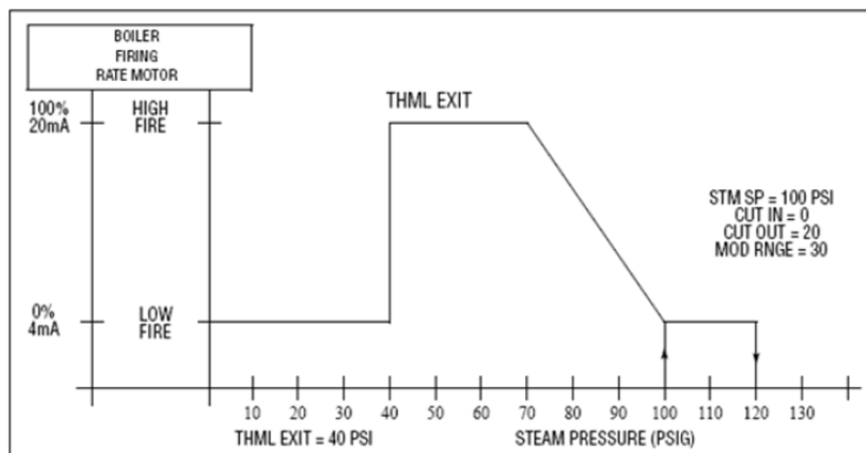

SEGMENT METHOD: This method of cold start thermal shock protection is generally used with Fire Tube Boilers. The setpoints associated with this method of thermal shock protection are:

- **THERMAL START** (Thermal Shock Start Point): Sets the start point for thermal shock protection. The firing rate is held at low fire, P03, until the thermal shock start point is achieved. The units and range displayed are determined by the sensor type selected.
- **THERMAL EXIT** (Thermal Shock Exit Point): Sets the steam pressure or water temperature exit point for thermal shock protection. Once this steam pressure (or water temperature) is reached, the firing rate is positioned according to the modulating control algorithm. The units and range displayed are determined by the sensor type selected.
- **TIMED OVERRIDE** (Timed Override Per Segment Setpoint): Sets the maximum time the NXF4000 holds the firing rate for each segment before automatically; increasing to the next segment. The allowable range is 0 to 30 minutes. If 0 is selected the control will move to the next segment only when the pressure or temperature reaches the next segment.

THERMAL START and THERMAL EXIT: Once the burner cycle starts, the NXF4000 will hold the firing rate in the low fire position until the steam pressure (or water temperature) reaches the Thermal Shock Start Point (**THERMAL STRT**). The NXF4000 divides the difference between the Thermal Shock Start Point (**THERMAL STRT**), low fire, and the Thermal Shock Exit Point (**THERMAL EXIT**) into sixteen (16) segments. The NXF4000 will increase the firing rate position by the value of one segment, and wait

until the steam pressure (or water temperature) increases by the amount of one segment before moving on to the next segment. Once the steam pressure (or water temperature) increases by the calculated amount, the NXF4000 increases the firing rate by the value of one segment and repeats the process. The NXF4000 steps the firing rate until the steam pressure (or water temperature) reaches the Thermal Shock Exit Point (**THERMAL EXIT**). At that point, the firing rate is at the high fire position, and will remain at the high fire position until the steam pressure (or water temperature) breaks into the proportional band.

NOTE:

1. If the sensor being used for thermal shock is the same type as the PCV sensor (steam or water) the Thermal Shock Exit value cannot be greater than the PCV setpoint.

TIMED OVERRIDE: The Timed Override Per Segment Setpoint (**THERMAL OVERRIDE**) allows the user to program a maximum time period, 0 to 30 minutes, in which the control will wait before forcing an increase in firing rate to the next segment position. If the steam pressure (or water temperature) DOES NOT increase to the appropriate value, the NXF4000 will automatically advance the firing rate position to the next segment position.

FIGURE 13.

Cold Start Thermal Shock Protection – Segment Method

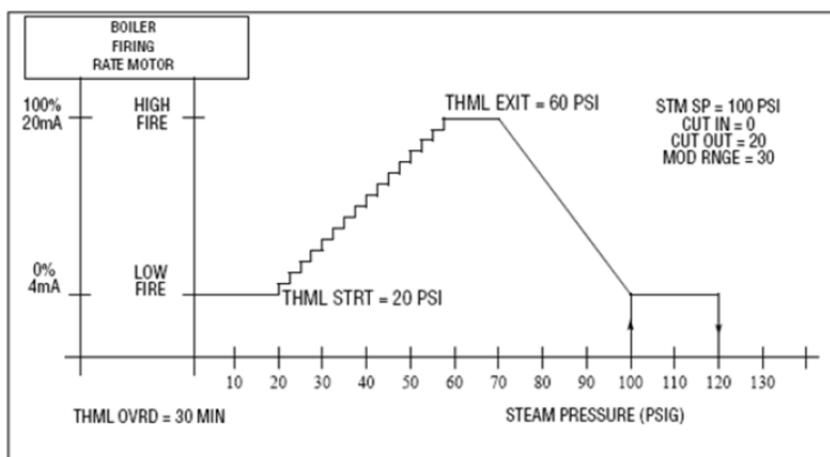

COMMUNICATIONS SETUP

The communications setup is needed to configure the NXF4000 to effectively perform Modbus and sequencing communications. Communication setup can be accessed from the top menu screen and the underlying setup screen is shown below:

<	C	O	M	M	U	N	I	C	A	T	I	O	N	S	E	T	U	P	
>	B	A	U	D	R	A	T	E						5	7	6	0	0	<
	U	N	I	T	A	D	D	R	E	S	S					2	4	7	

The baud-rate and unit address is configurable in the communication setup screen. The selections for baud-rates are: 57600 (default), 38400, 19200, 9600, 4800. In order for Modbus master and slave to communicate effectively, the baud-rate must be set to be identical at the master and the slave.

The selection for unit addresses are: 1 through 247, where 247 is default. It should be noted that an address conflict in the sequencing chain or Modbus chain will result in communication lockup, whereby devices with address conflict cannot effectively communicate. So, it is important that the addresses are unique on all communication devices.



SETBACK OPERATION

With the real time clock in the NXF4000, scheduled setback operation can be implemented to allow the system to operate to an alternate steam pressure or water temperature during off peak times. The scheduled setback time applies to every day of the week. That is, there are not individual setback times for each day of the week. Digital inputs are available that allow the user to override the setback operation for a pre-determined time when in setback mode or to place the system in a forced setback mode.

From the top layer menu, the user scrolls to SETBACK SETUP> and presses the NEXT key to access this submenu.

<	S	E	T	B	A	C	K		S	E	T	U	P									
>	S	E	N	S	O	R		U	S	E	D									1	<	
	L	I	M	I	T		T	Y	P	E									D	E	V	
	S	T	B	C	K		S	E	T	P	T			1	2	.	6	P	S	I		
	C	U	T		I	N											0	P	S	I		
	C	U	T		O	U	T										3	P	S	I		
	P	-	B	A	N	D											3	P	S	I		
	I	N	T	E	G	R	A	L													0	
	D	E	R	I	V	A	T	I	V	E												0
	E	N	D		S	T	B	C	K					5	:	3	0	A	M			
	B	E	G	I	N		S	T	B	C	K			1	0	:	0	0	P	M		
	O	V	E	R	R	I	D	E		H	O	U	R	S				0	-	8		
	S	T	B	C	K		S	U	N			A	L	L				S	T	B	C	K
	S	T	B	C	K		M	O	N				N	O				S	T	B	C	K
	S	T	B	C	K		T	U	E				N	O				S	T	B	C	K
	S	T	B	C	K		W	E	D				N	O				S	T	B	C	K
	S	T	B	C	K		T	H	U				N	O				S	T	B	C	K
	S	T	B	C	K		F	R	I				S	C	H	E	D	U	L	E		
	S	T	B	C	K		S	A	T			A	L	L				S	T	B	C	K

For setback to work properly the user should ensure the real time clock has been properly set up. See previous section titled REAL TIME CLOCK.

The sensor used option applies to sensor 1 and sensor 2. If no sensors are setup then USED cannot be selected. Typically sensor 1 is the process control variable and in the case of a steam boiler could be a common header sensor.

STBCK STEAM and STBCK WATER refer to the sensor selected and its configuration. Only sensors selected can be shown. (If a sensor selected is made unused at a later time then all setback setup information is cancelled or erased).

END STBCK (End Setback Period): This setpoint determines at what time the NXF4000 changes over from the setback setpoint to the normal setpoint (SETPOINT 1 or SETPOINT 2).

BGN STBCK (Begin Setback Period): This setpoint determines at what time the NXF4000 starts the setback schedule.

STBCK SUN (Daily Setback Options): This selects the options for operating in the setback mode for Sunday. These options are:

- **ALL STBCK** (All Setback). The NXF4000 controls the boiler at the setback setpoint for the entire day (24 hours).
- **NO STBCK** (No Setback). The NXF4000 DOES NOT setback the boiler for this day, but controls the boiler at the normal setpoint for the entire day (24 hours).
- **SCHEDULE** (Scheduled Setback) The NXF4000 controls the boiler according to the Setback Schedule for the time specified in END STBCK and BEGIN SETBCK.

SENSOR USED: 2
 SETPOINT: (set by user to the desired standby water temperature)

All other parameters are set to for SETPOINT 2 are user selectable based on need.



NOTICE: If a boiler is set up as a sequencing slave and is being commanded to be off by the master, the Standby Water function will override that and allow the slave boiler to run to maintain the Standby Water setpoint.

It is possible for the user to connect and configure either two temperature sensors or two pressure sensors to a NXF4000 and try to use one as the PCV and the other as Standby. However, this would probably not work well even if one-way valves were used. However, if the PCV sensor (Sensor 1) is a temperature sensor, the Standby Water sensor (Sensor 2) could be a pressure sensor. This would restrict the user to a standby water temperature always over the boiling point of water. If the user wishes to do that, the following Standby Water Temperature/Pressure Table can be used to calculate the standby water temperature.

Table 4: Standby Water Temperature/Pressure Table

Pressure PSI Gauge	Saturation Temp °F	Saturation Temp °C	Pressure PSI Gauge	Saturation Temp °F	Saturation Temp °C
1	215.92	101.82	110	344.16	173.42
10	239.35	115.19	120	350.05	176.69
20	258.74	125.96	130	355.60	179.78
30	273.99	134.44	140	360.87	182.70
40	286.70	141.50	150	365.87	185.48
50	297.65	147.58	160	370.63	188.13
60	307.31	152.95	170	375.19	190.66
70	315.99	157.77	180	379.56	193.09
80	323.89	162.16	190	383.76	195.42
90	331.15	166.19	200	387.80	197.66
100	337.88	169.93			

TRACK MODULATION

Track modulation is the application of a 4-20 mA signal to the sensor 1 input and having the modulation rate move the servos associated with the current profile to the corresponding firing rate position. The 4-20 mA input signal corresponds to 0% to 100% firing rate with 4 mA being 0% firing rate and 20 mA being 100% firing rate.

To use TRACK MODULATION, SENSOR 1 usage must be set to TRACK. There is no setpoint information associated with TRACK MODULATION as the firing rate is determined by the signal input level being applied. Typically the 4-20 mA signal is supplied from an external controller having its own pressure or temperature input and PID control.

When in TRACK MODULATION mode the PCV signal level is displayed as a 0 to 100% level corresponding to the level of the signal being applied. The modulation rate will be identical to this value and the servos will be moved to their respective positions corresponding to this modulation rate.

After burner turn on and safety start-up, in AUTO the servos will move to the position corresponding to the TRACK MODULATION input level.

Lockout and shutdown will occur if the TRACK MODULATION input exceeds 21mA or goes below 3mA.



NOTICE: Track modulation bypasses the ability for the NXF4000 to control the burner using its internal setPoint control. It is recommended that the user configure a digital input for BURNER ON/OFF or TRACK MOD ENABLE/DIASABLE.

VALVE PROVING

The NXF4000 offers an intelligent Valve Proving System (VPS). It checks the effective closure of automatic shut-off valves by measuring the pressure differential between two fuel shutoff valves during the test sequence. When active, it will open and close the main safety shutoff valves (double block valve arrangement) in the proper sequence and monitor the pressure in the gas pipe between the two safety shutoff valves (MV1 & MV2).



WARNING: It is the responsibility of the installing and operating personnel to ensure that the valve proving system is properly installed and configured. The appropriate permissible leakage rate information should be used when setting up a valve proving system. Please consult the burner manufacturer and/or applicable codes, ordinances, and regulations.

The gas pressure sensing device, pressure switch, is recommended to be installed between the two shutoff valves. The two common methods of pressure switch setup are described below:

Method 1: A single pressure switch installed between the shutoff valves.

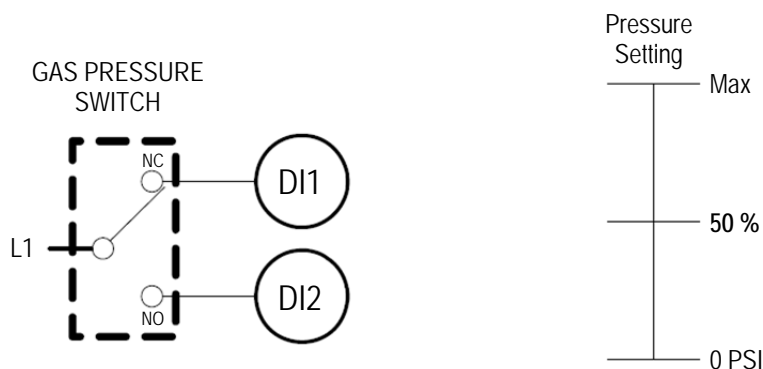

This setup requires that the gas pressure switch be adjusted to $\frac{1}{2}$ the gas train pressure. The rule of operation is quite simple: The pressure switch will "make" (DI2 high) when gas pressure in the test section exceeds the set pressure; it will "break" (DI1 high) when the gas pressure falls below the set pressure.

Method 2: Dual pressure switches installed between the shutoff valves.

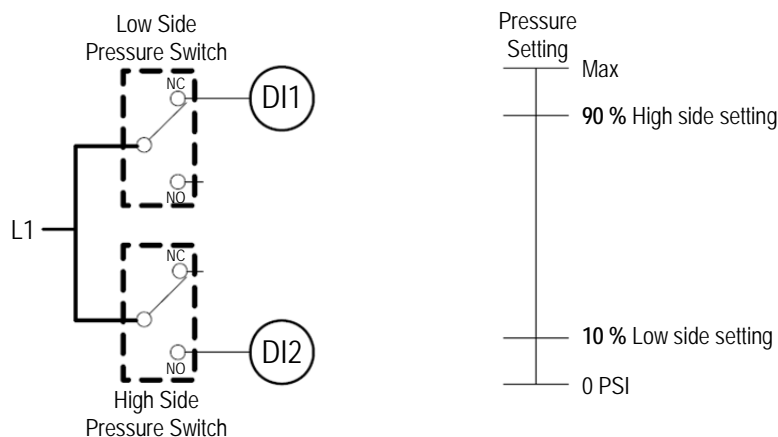

This setup requires that the gas pressure switches be adjusted to levels closer to the high and low pressure windows. Thus, allowing for the detection of trace amount of gas leakage and it also reduces the overall TEST times. The rule of operation is similar to the single pressure switch setup: The pressure switch will "make" (DI2 high) when gas pressure in the test section exceeds the high side set pressure; it will "break" (DI1 high) when the gas pressure falls below the low side set pressure.

Pressure Switch Selection

1. Determine the maximum inlet pressure for the upstream valve.
2. For method 1, divide the inlet pressure by 2 (50%) and select a gas pressure switch that will trip at the half-way point. For adjustable type pressure switches, adjust the setting to the desired trip point.
3. For method 2, determine the trip point for the high and low side pressure. Select pressure switches to satisfy the high and low side pressure settings. For adjustable type pressure switches, adjust the setting to the de-sired trip point.

Proper hookup and configuration of the digital inputs are required in order to properly operate the valve proving feature. The NXF4000 is designed to allow valve proving to be performed at the beginning or at the end of a burner cycle. NXF4000 supports valve proving for 2-valve system, 3-valve system with normally-open vent valve, and 3-valve system with normally-closed vent valve. The 2-valve system is a setup with an upstream and downstream shutoff valves and the test gas is evacuated into the combustion chamber. The 3-valve system is generally equipped with a Vent valve that evacuates the test gas into the atmosphere.

During the valve proving operation, the test section of the gas train is pressurized and evacuated in a methodical fashion. During the test sequence, the NXF4000 allows the test section to be pressurized for 3 seconds and evacuated for 3 seconds. The pressurization or evacuation time cannot be adjusted. It is recommended that a qualified personnel make the adjustments to the TEST times at the burner standby state. See Valve Proving Setup under the Burner Control Setup menu for configuration.

The wiring for the valve proving system is as follows:

Upstream Shutoff valve (MV1) should be wired to **P5.4 (GAS 1)**

Downstream Shutoff valve (MV2) should be wired to **P5.5 (GAS 2)**

Vent valve (if equipped) should be wired to **P5.9 (VENT)**

Gas pressure switch NO position should be wired to any available digital inputs

Gas pressure switch NC position should be wired to any available digital inputs

2-Valve system:

Two valves (MV1 and MV2) are cycled to prove that neither gas valve leaks above an acceptable rate using the following method described below:

FIGURE 15.

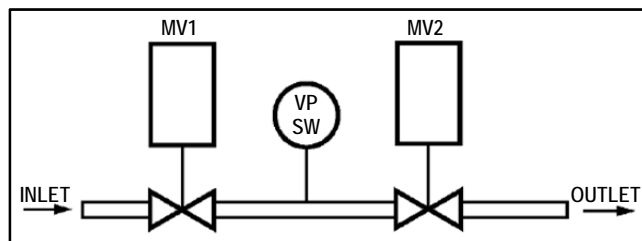
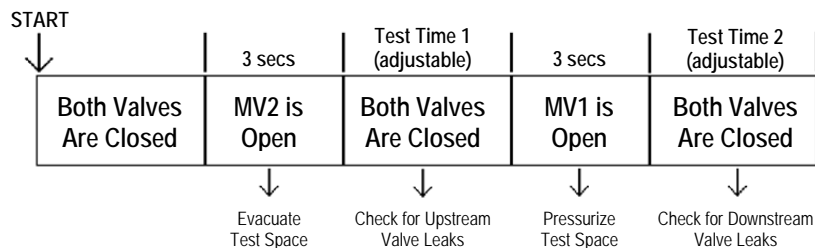

FIGURE 16.



Proving steps:

1. Both safety shutoff valves are in the closed position at the start of valve proving sequence.
2. The downstream valve (MV2) is energized (open) for 3 seconds. Thus, evacuating the test space.
3. The downstream valve is closed after the evacuation time.
4. The system monitors the pressure switch within the configured TEST TIME 1 window to verify that the upstream valve is not leaking. If the pressure switch is energized (makes) during this window, the system will stop the valve proving test and proceed to lockout. Otherwise, the system will proceed to the next phase of the test.
5. The upstream valve (MV1) is open for 3 seconds. Thus, pressurizing the test space.
6. The upstream valve is closed after the pressurization time.
7. The system monitors the pressure switch within the configured TEST TIME 2 window to verify that the downstream valve is not leaking. If the pressure switch is de-energized (drops out) during this window, the system will stop the valve proving test and proceed to lockout.
8. Upon successful completion of TEST TIME 2, the valve proving test is deemed complete and the NXF4000 proceeds to start the pre-purge cycle.

3-Valve system:

Two valves (MV1 and Vent) are cycled to prove that none of the three gas valves (MV1, MV2, or VENT) leak above an acceptable rate using the following method described below:

FIGURE 17.

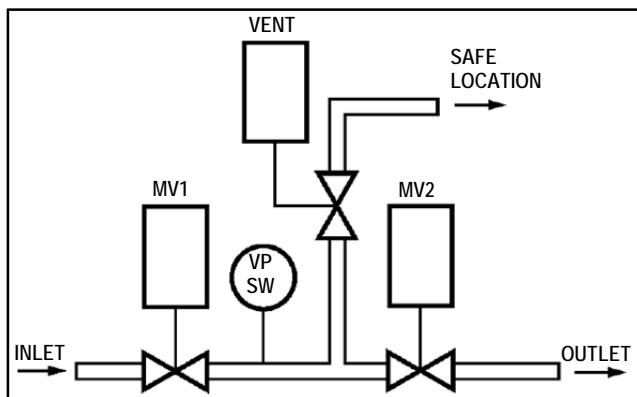
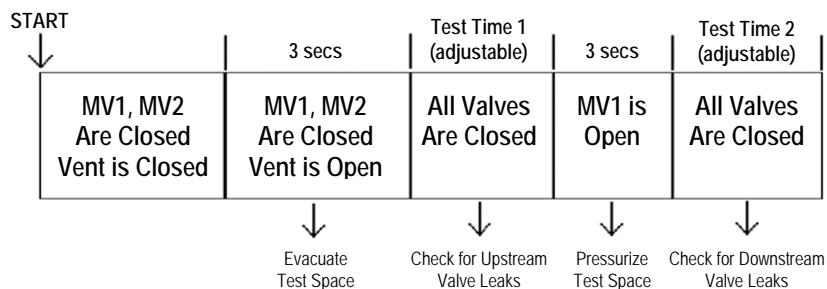

FIGURE 16.



Proving steps:

1. Both safety shutoff valves are in the closed position at the start of valve proving sequence.
2. The Vent valve is energized (open) for 3 seconds. Thus, evacuating the test space.
3. The Vent valve is closed after the evacuation time.
4. The system monitors the pressure switch within the configured TEST TIME 1 window to verify that the upstream valve is not leaking. If the pressure switch is energized (makes) during this window, the

system will stop the valve proving test and proceed to lockout. Otherwise, the system will proceed to the next phase of the test.

5. The upstream valve (MV1) is open for 3 seconds. Thus, pressurizing the test space.
6. The upstream valve is closed after the pressurization time.
7. The system monitors the pressure switch within the configured TEST TIME 2 window to verify that the downstream valve is not leaking. If the pressure switch is de-energized (drops out) during this window, the system will stop the valve proving test and proceed to lockout.
8. Upon successful completion of TEST TIME 2, the valve proving test is deemed complete and the NXF4000 proceeds to start the pre-purge cycle.

CALCULATING TEST TIMES

The valve proving test times are expected to be calculated by using the following formula:

$$Test\ Time = \frac{\Delta P \times V_p \times C}{P_{ATM} \times V_{LEAK}}$$

Where:

- Test Time = Duration of proving time (in seconds)
- ΔP = Difference between inlet pressure and the switch point of pressure switch
(English -- psi, Metric -- mbar)
- V_p = Volume of test section (English -- ft³, Metric -- dm³)
- C = Formula constant (3600 sec/hr)
- P_{ATM} = Atmospheric pressure (default 14.7 psi or 1013 mbar)
- V_{LEAK} = Permissible leak rate for valves (English -- ft³/hr, Metric -- liters/hr)

In many cases, the volume of the test section, V_p , between the gas shutoff valves is specified in the gas train manual. Alternatively, the volume can be calculated by:

V_p = Volume of the test pipe between the valves + volume of the upstream valve outlet cavity + volume of the downstream outlet cavity.



WARNING: It is the responsibility of the installing and operating personnel to ensure that the valve proving system is properly installed and configured. The appropriate permissible leakage rate information should be used when setting up a valve proving system. Please consult the burner manufacturer and/or applicable codes, ordinances, and regulations.

As specified in EN 1643:2014 standard, a valve proving system must be leak-tight such that:



- No single component of a VPS shall have a leak rate greater than 60 cm³/hr (0.00212 ft³/hr) for non-integrated double block valves.
- No single component of a VPS shall have a leak rate greater than 120 cm³/hr (0.00424 ft³/hr) for integrated or partially integrated double block valves.

As specified in FM 7400 standard, a valve proving system must be leak-tight with a leak rate no greater than 24in³/hr (0.0138 ft³/hr, 393 cm³/hr)

In certain cases, local codes may require the factoring of the burner capacity in order to derive the leak rate. For example, it could be specified that the leakage shall not be greater than 0.01% of burner capacity.

Example of Test Times Calculation:

Assume a valve proving installation with an integrated valve train consisting of total volume of 0.018 ft³, and an inlet pressure of 0.5 psi and a permissible leakage rate of 0.04 ft³/hr for upstream valve and 0.035 ft³/hr for downstream valve. Assume a single pressure switch is installed and set to trip at 50% of the inlet pressure. Calculate the expected test times for such system.

$$\text{Test Time 1} = \frac{(0.5 - 0.25) \times 0.018 \times 3600}{14.7 \times 0.04} = 27.6 \text{ s}$$

$$\text{Test Time 2} = \frac{(0.5 - 0.25) \times 0.018 \times 3600}{14.7 \times 0.035} = 31.5 \text{ s}$$

For the example above, round up TEST TIME 1 to 30 seconds and TEST TIME 2 to 35 seconds.



OPERATING SEQUENCE

This NXF4000 control performs burner start-up and shut-down by utilizing the built-in burner flame safeguard controller. This integrated flame safeguard controller provides burner management functions such as flame detection, interlock safety, combustion air flow monitoring as well as controlling the combustion air fan, ignition, pilot valve(s) and main fuel valve(s).

The start-up and shutdown sequence is handled by a progression of stages, each requiring a certain set of conditions to move on to the next stage. The current burner stage is usually shown on the NXD410 User Interface placed after the current burner status. The following describes each possible stage.

LOGIC STATE	MESSAGE	DESCRIPTION
s00	POST s00	Power On Self Test. State only appears upon the initial application of power.
s01	STANDBY s01	Burner is in off condition. Burner control switch is open. Keypad Burner ON/OFF commanding burner off. Servos are in P00 position.
s02	WAIT FOR PROFILE s02	Once the pre-conditions for start-up is satisfied, including profile selection, the NXF4000 turns on the blower.
s03	VALVE PROVING	If system is configured to perform valve proving, the NXF4000 commences the checking of the upstream and downstream gas valves for leaks.
s04		
s05		
s06		
s07	MOVE TO PURGE s07	The NXF4000 sends a command to the AIR servo and/or VFD drive to move to the purge position.
s08	PURGE s08	Servo motors (VFD) at purge position. Purge timer starts countdown.
s09	MOVE TO IGNITION s09	Purge time complete. NXF4000 commences light-off sequence by commanding the servos to the ignition position.
s10	N/A s10	
s11	PTFI	Pilot Trial For Ignition state. NXF4000 tries to establish the pilot flame by driving the Ignition (P5-6), Pilot (P5-7), and Main Valve MV1 (P5-4) terminals.
s12	PILOT	Pilot stabilization state.
s13	MTFI	Main Trial For Ignition state. NXF4000 tries to establish the main flame by maintaining the pilot flame while turning on the main fuel valves.
s14	MFEP	Main Flame Establishment Period.
s15	MOVE TO LOW FIRE s15	Completes light-off sequence and moves to AUTO.
s16	AUTO s16	NXF4000 begins modulation to satisfy demand.
s17	POST-PURGE s17	NXF4000 commences a controlled shutdown: pressure/temperature satisfied, recycle limit open, burner on/off keypad commands burner off. The Blower output is active for the duration of the post-purge time. A transition to State s01 is followed.
s18	LOCKOUT s18	All lockouts go to this stage.

FIGURE 19. System Wiring Diagram NXF4000

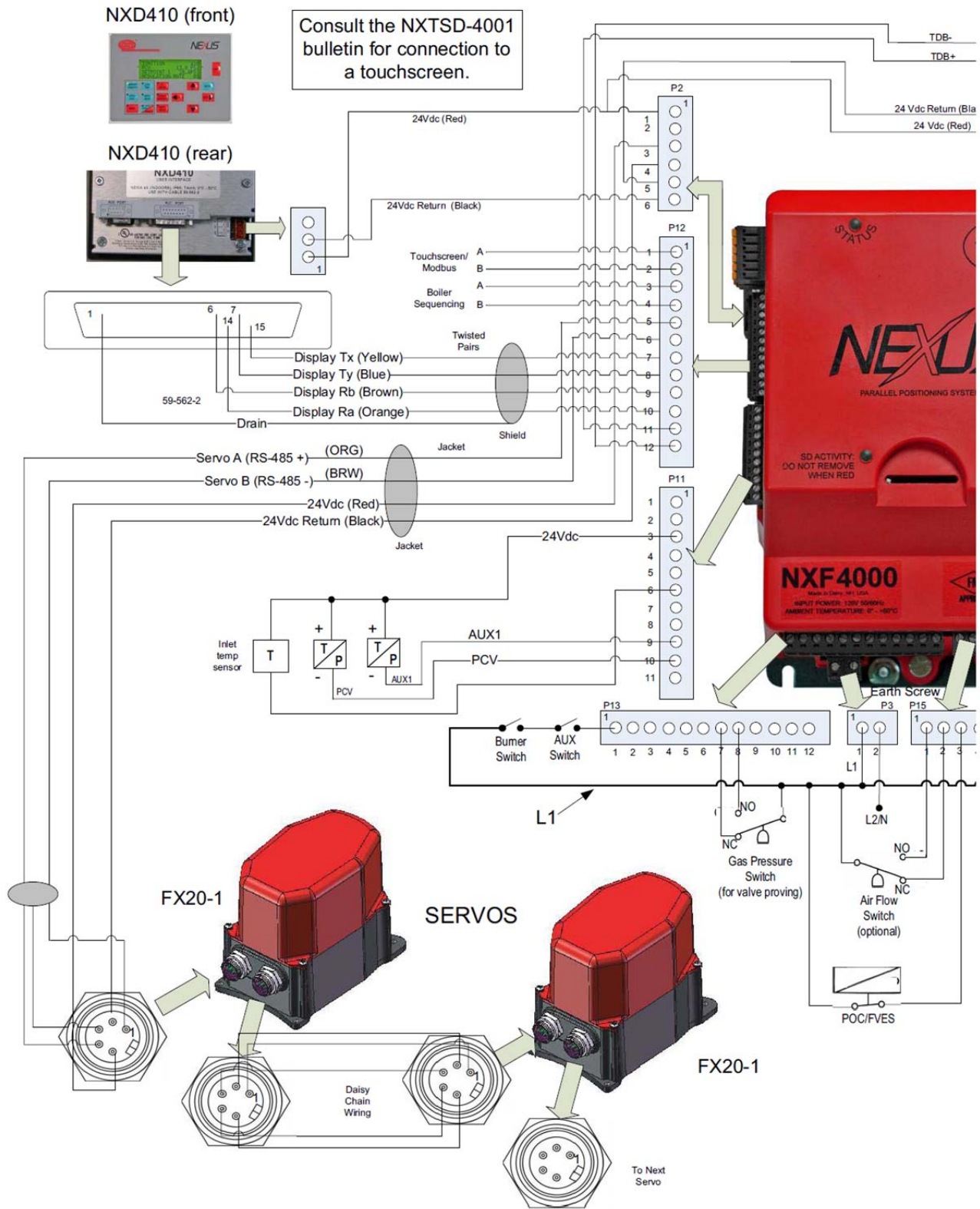

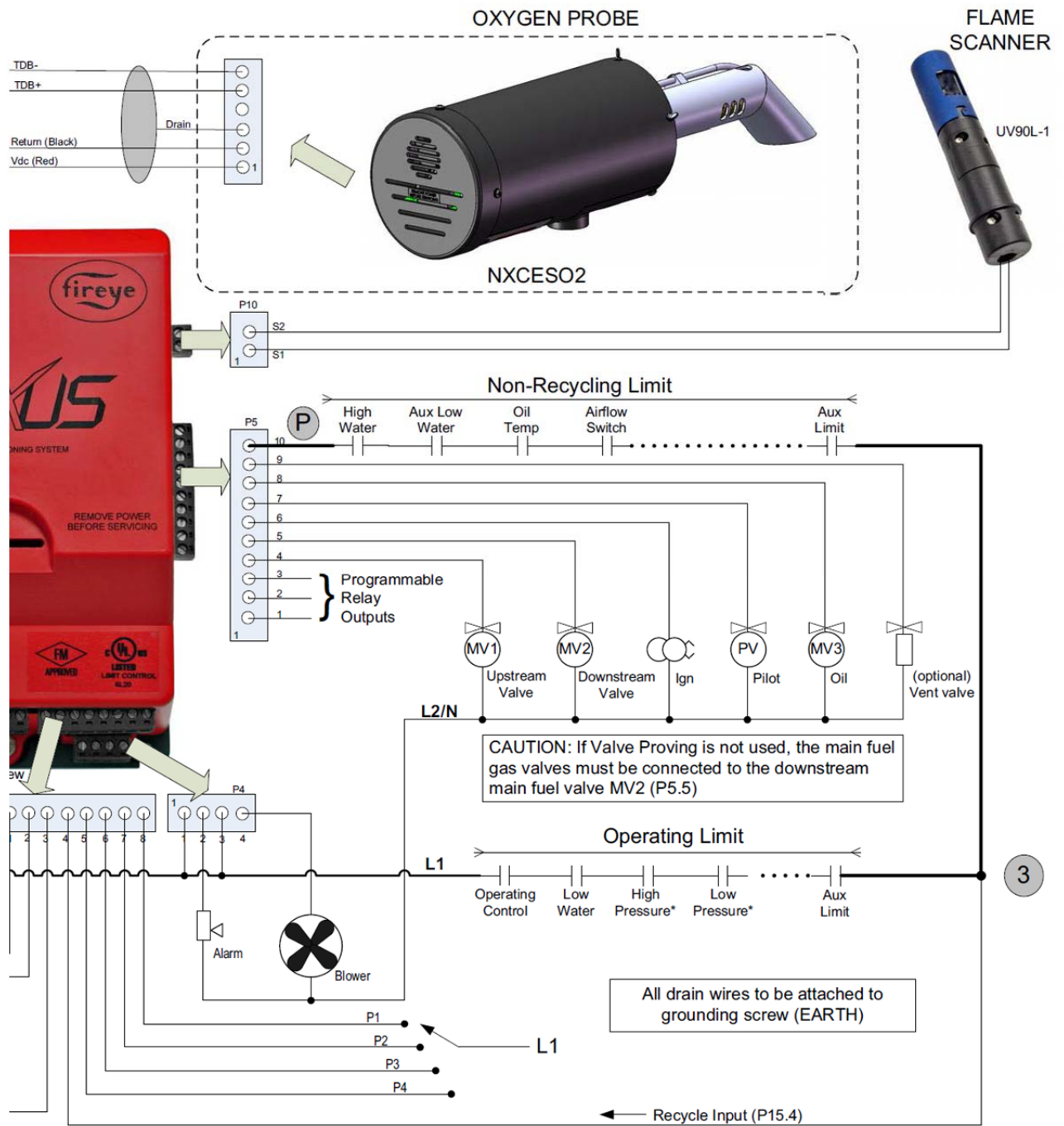

NXF4000 System
Wiring Diagram

Revision 1.1

NXF4000-WD

BOILER SEQUENCING

Sequencing is used in a multiple boiler (2-6) environment where a master boiler, during normal operation, is established to control the remaining slave boilers in order to achieve the desired setpoint as set in the master boiler. Any boiler can be a master, and in a sequencing operation, only one boiler can be the master at a time. In a sequencing operation, the slave boilers are allowed to come on line and control their own firing rate to maintain a 'warm' state so they can be ready when called upon by the master boiler. SENSOR 2 will be configured as STANDBY WATER and SETPOINT 2 will be configured to use SENSOR 2 with the appropriate setpoints. The STANDBY WATER operation is the mode of operation of the slave boiler when the master boiler is not demanding any help from the slave to maintain the system pressure/temperature. This mode of operation is the default startup state that the slaves will normally be in until they are commanded to be online by the master boiler control.

The master boiler controls the individual slave's operation through an independent sequencing only communications link. The independent communications link is located on terminals P12.3 (SEQUENCING A) and P12.4 (SEQUENCING B). Refer to the WIRING CONNECTIONS section. A twisted shielded pair is recommended such as Belden and each unit is daisy chained to the next unit. That is, a cable is routed from the first unit to the second unit (A connected to A | B connected to B), from the second unit to the third unit and from the third unit to the fourth unit, and soon. The drain wires are connected to each other and at the first and last unit the drain wire is connected to chassis or earth ground.

P12	
1.	mbus A
2.	mbus B
3.	seq A
4.	seq B
5.	servo A
6.	servo B
7.	dis TX, ye
8.	dis TY, bl
9.	dis Rb, br
10.	dis Ra, or
11.	O2 A
12.	O2 B



Before the SEQUENCING sub menu is accessed the COMMUNICATION SETUP menu should be accessed where each boiler is given a unique address. The address will be used to identify the master and slaves. The baud rate for sequencing is unique and independent from the baud rate shown in the COMMUNICATION SETUP sub menu.

A boiler is made a master through keypad setting, digital input or the Modbus communication gateway. The system has to be instructed as to which method is selected through the SEQUENCING SETUP menu. Below is the complete SEQUENCING sub menu with the assumption that 3 slaves are available with addresses 3, 2 and 4 respectively.

<	S	E	Q	U	E	N	C	I	N	G	S	E	T	U	P							
>	M	A	S	T	E	R		S	L	C	T				K	E	Y	P	A	D	<	
	S	L	A	V	E	S		A	V	A	I	L	A	B	L	E					3	
	1	S	T		S	L	A	V	E		O	N									3	
	2	N	D		S	L	A	V	E		O	N									2	
	3	R	D		S	L	A	V	E		O	N									4	
	S	L	A	V	E		O	N		R	A	T	E							8	0	%
	S	L	A	V	E	3		O	N		D	L	Y								2	m
	S	L	A	V	E	2		O	N		D	L	Y								3	m
	S	L	A	V	E	4		O	N		D	L	Y								6	m
	S	L	A	V	E		O	F	F		R	A	T	E						3	0	%
	S	L	A	V	E		O	F	F		D	E	L	A	Y						2	m

MASTER SELECT METHOD

This parameter provides for the selection of the master boiler via the keypad, digital input or communications. The available selections are:

UNUSED: No SEQUENCING selected, operates on own PID.

KEYPAD: Master selection via the Keypad - the LEAD/LAG button is used to select the master.

INPUT: Master via digital input. (Refer to DIGITAL INPUT select)

COMMS: Master selection via Modbus communications or touchscreen.



LEAD/LAG LED Status

The LED associated with the LEAD/LAG push button is active only when the master select method is KEYPAD can have the following state:

OFF Boiler is in slave mode

ON Boiler is in master mode

BLINKING Boiler is transitioning from slave to master, or from master to slave.

Note: Status of sequencing master can also be verified by hitting the HOME key and reviewing the top line. If sequencing master is active, the top line should read AUTO(m)

SEQUENCING CONFIGURATION

The master boiler is programmed as to how many slaves exist, the order in which slaves are turned on, the modulation firing rate that, when exceeded, will begin the slave turn on procedures and the delay on and off time for each slave to be turned on and off. Below is a table showing parameters programmed into each master. The value in the last column of the 1st, 2nd, and 3rd Slave On values are the communication addresses previously mentioned that the slaves are set to within each of their own "Communication" setup menus.

SLAVES AVAILABLE

Each master is programmed as to how many slaves it will be controlling. The minimum is 0 and the maximum is 5. The remaining items in the SEQUENCING sub menu will be dependent on the slaves available.

1ST SLAVE ON (communication address)

2ND SLAVE ON (communication address)

3RD SLAVE ON (communication address)

The order in which each slave is commanded on is programmed into the master's parameters using each slave's communication address to identify each slave. Each boiler must have its own unique communication address identifier. Each boiler in the system, if it can be a master, must indicate the priority order of the remaining boilers in the system. The priority is not restricted to ascending or descending addresses. In fact, each master can have a different priority order of the remaining slaves.

Note: Communication addresses should NEVER be changed while the boilers are in sequencing (more than one boiler on). Established operation will be disrupted.

	S	L	A	V	E	S		A	V	A	I	L	A	B	L	E				3
>	1	S	T		S	L	A	V	E		O	N								3
	2	N	D		S	L	A	V	E		O	N								2
	3	R	D		S	L	A	V	E		O	N								4



When configured, SETPOINT 2 is used as the STANDBY WATER setpoint. Although commanded to remain off by the master, each slave is to maintain the STANDBY WATER setpoint which is typically the 'warm' state. When commanded to be on by the master boiler, the slave's SETPOINT 2 setpoint values are ignored because its operation and firing rate is controlled by the master boiler. While in STANBY WATER, the slave will modulate according to its own PID.

The master boiler has to be operational and controlling the system in order for the master to assume control. The slave boiler state is initially in the "STANDBY" state when the master is not calling for any additional support to maintain the system. If the slave boiler is in any other initial state, then the slave must be commanded to go to the "STANDBY" state until the master determines that a state change is needed.

SLAVE ON RATE (1-100%)

This value determines the firing rate of the master boiler at which the first and all subsequent slave boilers come on. Slaves are brought on line according to the priority order previously discussed. The master and the last slave on will modulate in unison controlled by the master.

SLAVE 1 ON DELAY (0-255 minutes)

SLAVE 2 ON DELAY (0-255 minutes)

SLAVE 3 ON DELAY (0-255 minutes)

The timer to command a slave on begins when the modulation rate exceeds the SLAVE ON RATE. While the time set above is expiring and the boiler load falls below the slave ON RATE, the command to begin to bring on the slave will be cancelled. After the first slave is commanded on and reaches AUTO and the master's modulation rate is still above the SLAVE ON RATE (expected), the timer to bring on the next slave is initiated. A value of 0 will initiate the next slave to turn on as soon as the slave ON RATE is exceeded.

S	L	A	V	E		O	N		R	A	T	E			8	0	%		
>	S	L	A	V	E		3		O	N		D	L	Y			2	m	<
	S	L	A	V	E		2		O	N		D	L	Y			3	m	
	S	L	A	V	E		4		O	N		D	L	Y			6	m	

SLAVE OFF RATE (1-100%)

When the master boiler and last slave boiler on modulate below this rate and exceed the time value set in SLAVE OFF DELAY, the last slave commanded on will be turned off. At this point, the master and the previous (if any) commanded on slave will begin to modulate in unison until they together are below this setting. This will continue until only the master boiler remains on.

The slave OFF RATE can never be equal to or larger than the slave ON RATE.

SLAVE OFF DELAY (0-255 minutes)

This option sets the time delay when the modulation rate is at or below the value set in SLAVE OFF RATE and the last slave turned on being turned off. This also sets the time delay between successive slaves being turned off should the modulation rate stay below the SLAVE OFF RATE setting. The slave off delay is common to all slaves.

S	L	A	V	E		4		O	N		D	L	Y			6	m			
>	S	L	A	V	E		O	F	F		R	A	T	E			3	0	%	<
	S	L	A	V	E		O	F	F		D	L	Y				2	m		

OPERATION NOTES:

If the master boiler is turned off, fails to come on within 30 seconds, or goes to lockout while operating as the master, it will stop communicating and sequencing will be disabled. All slave boilers will revert to their own PID settings.

Should a slave boiler fail to come on within 3 minutes, due to a burner limit being off, lockout or associated lockout in the flame safeguard, the master will call for the next slave in the priority list. Extended purge time in a slave's flame safeguard control is considered normal operation and the master will wait through the extended purge.

Although it was previously stated there can be only one master, there will be times when the user will attempt to make a slave a master while a master is still in existence.* The current master will continue to be a master until it is made a slave and the new master will continue to be a slave until no further communications is received from the previous master. It was previously established that there is a communication timeout of 30 seconds. It is expected the user will eventually make the former master a slave and at that time it should stop communicating as a master and now the new master can take control. When the new master takes control it will of course operate according to its own PID and control under its SETPOINT 1 parameters. The former master will await commands from the new master.

If the master boiler is switched to manual modulation it will remain as master bringing on slave boilers as required. This will allow the master boiler to be "base loaded" if required, yet still control the slaves. If a master boiler is base loaded, it still continues to calculate its theoretical firing rate using its pre-programmed PID settings. If the calculated firing rate output exceeds the ON RATE, the master will begin to bring on the slave boilers and set their firing rate to the calculated firing rate output.

During system startup, if the master boiler is in a thermal shock state trying to get to AUTO, it will cease communications to the slaves, allowing the slaves to operate under their own PID settings.

If the SD card is used to restore data to a NXF4000 that is operating in a sequencing environment, the communication and sequencing sub menus should be checked and verified for proper configuration.

Within the INFO screen, the variable SEQUENCING displays the current state of the control.

0 = none (sequencing not selected)

1 = slave

2 = master

3 = none going to slave

4 = none going to master

5 = slave going to none

6 = master going to none

7 = slave going to master

8 = master going to slave



NOTICE: Leaving a second burner's lead/lag switch "on" (with LED flashing) will put it into "Master Standby". If the current lead selected boilers' FSG faults (i.e. flame failure, external limits are open, or the NXF4000 faults), the "Master Standby" will assert itself as "Master" once the current lead's communications is terminated.

Sequencing Configuration Example

Boiler 1

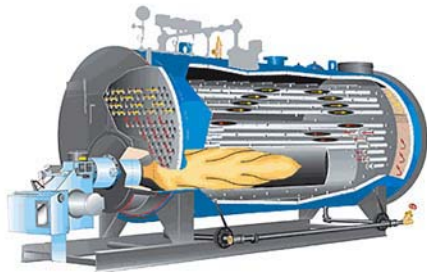

Master Boiler

Boiler 2

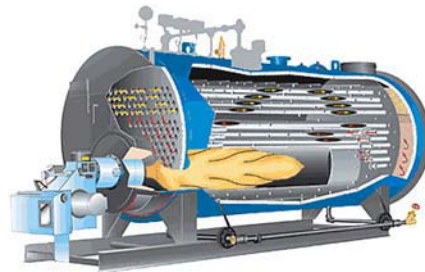

Slave Boiler

Communication Setup		Communication Setup	
Baud Rate	57600	Baud Rate	57600
Unit Address	1	Unit Address	2
Sequencing Setup		Sequencing Setup	
Master Slct	Keypad	Master Slct	Keypad
Slaves Available	3	Slaves Available	3
1 st Slave On	2	1 st Slave On	3
2 nd Slave On	3	2 nd Slave On	4
3 rd Slave On	4	3 rd Slave On	1
Slave On Rate	80%	Slave On Rate	80%
Slave #2 On Dly	5 mins	Slave #3 On Dly	5 mins
Slave #3 On Dly	5 mins	Slave #4 On Dly	5 mins
Slave #4 On Dly	5 mins	Slave #1 On Dly	5 mins
Slave Off Rate	30%	Slave Off Rate	30%
Slave Off Dly	8 mins	Slave Off Dly	8 mins

Sequencing Configuration Example

Boiler 3

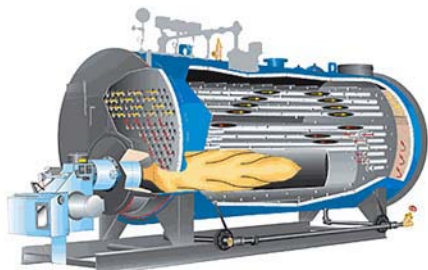

Master Boiler

Boiler 4

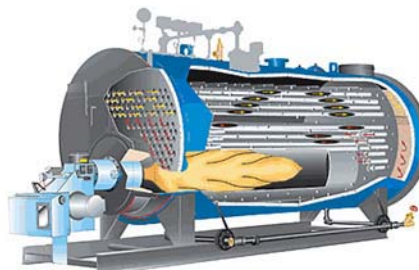

Slave Boiler

Communication Setup		Communication Setup	
Baud Rate	57600	Baud Rate	57600
Unit Address	3	Unit Address	4
Sequencing Setup		Sequencing Setup	
Master Slct	Keypad	Master Slct	Keypad
Slaves Available	3	Slaves Available	3
1 st Slave On	4	1 st Slave On	1
2 nd Slave On	1	2 nd Slave On	2
3 rd Slave On	2	3 rd Slave On	3
Slave On Rate	80%	Slave On Rate	80%
Slave #4 On Dly	5 mins	Slave #1 On Dly	5 mins
Slave #1 On Dly	5 mins	Slave #2 On Dly	5 mins
Slave #2 On Dly	5 mins	Slave #3 On Dly	5 mins
Slave Off Rate	30%	Slave Off Rate	30%
Slave Off Dly	8 mins	Slave Off Dly	8 mins



INFO SCREEN

Pressing the info button on the NXD410 keypad display would reveal a screen with system information that is useful for setup and diagnostics. By utilizing the UP and DOWN keys, you can scroll through all available info screen items. Here is list of available INFO screen items:

I	N	F	O		S	C	R	E	E	N											
>	S	T	A	T	U	S												R	U	N	<
	P	R	O	F	I	L	E		S	E	L	E	C	T	E	D					1
	P	R	O	F	I	L	E		S	E	T	P	O	I	N	T	S			1	2
	C	U	R	R	E	N	T		R	N	G					P	3	-	P	4	
	S	V	1	(A	I	R)	E	B	2	2						3	0	°	
	S	V	2	(G	A	S)	E	B	2	2						1	2	°	
	S	V	3	(O	I	L)	E	B	2	2							1	°	
	A	N	A	0															0	%	
	V	F	D	1														5	0	0	
	V	F	D	2													0	.	0	%	
	D	I	[1	-	4]							1	,	X	,	X	,	0	
	D	I	[5	-	8]							1	,	0	,	0	,	X	
	D	I	[9	-	1	2]						X	,	X	,	X	,	X	
	D	I	[1	3	-	1	5]							X	,	X	,	1	
	O	P	E	R	A	T	I	N	G		C	O	N	T	R	O	L			1	
	Z	-	C	A	L													8	4	5	
	M	O	D	U	L	A	T	I	O	N		M	O	D	E					4	
	C	O	M	M	A	N	D		R	A	T	E						2	5	%	
	P	C	V		V	A	L	U	E							2	8	p	s	i	
	S	E	T	P	O	I	N	T								3	5	p	s	i	
	S	E	T	P	T		1							S	E	N	S	O	R	1	
	S	E	T	P	T		2							S	E	N	S	O	R	2	
	S	E	T	P	T		3							S	E	N	S	O	R	3	
	T	H	M		S	H	K							S	E	N	S	O	R	1	
	S	E	T	B	A	C	K							S	E	N	S	O	R	2	
	L	S	C		R	6	:	0	0	1	A		R	9	:	0	0	0	0		
	B	U	R	N	E	R		H	O	U	R	S								5	
	B	U	R	N	E	R		C	Y	C	L	E	S							2	5
	S	Y	S	T	E	M		H	O	U	R	S						3	4	5	
	S	T	A	C	K		T	E	M	P						3	5	0	°	F	
	O	2		L	E	V	E	L									6	.	3	°	
	O	2		T	A	R	G	E	T								6	.	0	°	
	O	2		A	M	B	.	T	E	M	P						5	5	°	F	
	O	2		S	T	A	T	U	S					0	x	0	0	0	0		
	S	E	Q	U	E	N	C	I	N	G										0	
	I	N	T	E	R	N	A	L		T	E	M	P				9	2	°	F	
	F	S	G		E	R	R	O	R		C	O	D	E						0	
	F	S	G		B	O	A	R	D										U	V	
	F	S	G		F	L	A	M	E									1	0	0	
	F	S	G		P	U	L	S	E	S								8	0	0	
	M	A	I	N		R	E	V										x	.	x	



H	E	L	P	E	R		R	E	V								X	.	X
P	I	D		R	E	V											X	.	X
V	F	D		R	E	V											X	.	X
O	2		R	E	V												X	.	X
F	S	G		R	E	V											X	.	X

MESSAGES EXPLAINED:

STATUS -- Available messages are RUN or LOCKOUT

PROFILE SELECTED -- Shows current selected profile (1, 2, 3, or 4)

PROFILE SETPOINTS -- Shows total commissioned points (up to 24 programmed points).

CURRENT RNG -- System will display the current profile point during normal modulation, commissioning, or adjust ratio.

SVx -- Available system servos are shown. The servo name and the firmware CRC are displayed.

ANA0 -- Current analog output position.

VFDx -- Current VFD(x) position.

DI [.....] -- Digital Input states.

OPERATING CONTROL -- Current state of recycle input.

Z-CAL -- PID daughtercard calibration constant.

MODULATION MODE -- Current reason for modulation: 0-AUTO, 1-Digital Input, 2-Keypad, 3-Sequencing Master, 4-Keypad Low Fire Hold, 5-Standby Water, 6-Thermal Shock, 7-LowStack, 8-Purge Hold, 9-Track.

COMMAND RATE -- Current burner firing rate (0 - 100%)

PCV VALUE -- Current Sensor 1 (PCV) value.

SETPOINT -- Current system setpoint.

SETPT x -- Shows the system sensor attached to the setpoint control.

THM SHK -- Shows the system sensor attached to the thermal shock control.

SETBACK -- Shows the system sensor attached to the thermal shock control.

LSC -- System information for factory use only.

BURNER HOURS -- Cumulative time record of burner operating hours.

BURNER CYCLES -- Cumulative time record of call-for-heat attempts.

SYSTEM HOURS -- Cumulative time record of system power-on hours.

STACK TEMP -- Current stack temperature as reported by the O2 Probe.

O2 LEVEL -- Current oxygen level as reported by the O2 Probe.

O2 TARGET -- Oxygen trim target value as commissioned.

O2 AMB. TEMP -- Current ambient temperature around the O2 Probe as reported by the O2 Probe.

O2 STATUS -- O2 Probe status. See NXCESO2 bulletin for more information.

SEQUENCING -- Current sequencing state. See Sequencing section for more information.

INTERNAL TEMP -- Internal temperature of the NXF4000.



FSG ERROR CODE -- Amplifier card status: 0-OK, 1-LOCKOUT.

FSG BOARD -- Installed amplifier card type. Options are UV, IR, & DC.

FSG FLAME -- Normalized flame strength information [0 - 100%]

FSG PULSES/OHM -- Raw flame strength information.

MAIN REV-- Main MCU firmware revision.

HELPER REV-- Helper MCU firmware revision

PID REV -- PID MCU firmware revision.

VFD REV -- Installed VFD card firmware revision.

O2 REV -- Installed O2 Probe firmware revision.

FSG REV--Installed amplifier card firmware revision

SD CARD OPERATION

The NXF4000 provides the means to backup and restore settings and profile data using a secure digital (SD) memory card. The front of the NXF4000 contains a slot where the SD card is inserted and removed. An LED is included that illuminates when SD operations are being processed. NXF4000 units are shipped with a **16GB SDCARD** media installed. An SD card should never be inserted or removed while the LED is lit.

Figure 12

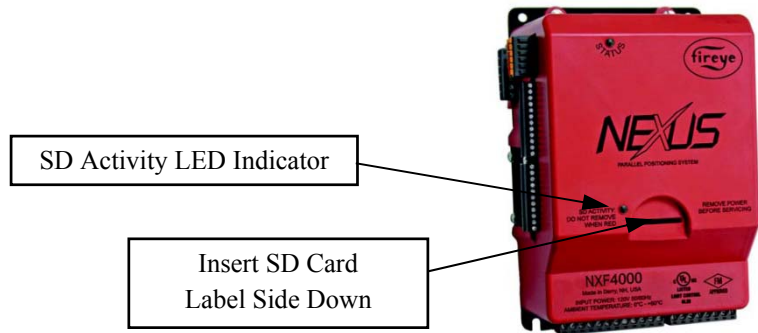

SD cards are available in various types and capacities. The different types are SDSC (standard capacity), SDHC (high capacity) and SDXC (extended capacity). SDHC types have a capacity ranging from 4GB to 32 GB. SDHC types use FAT32 only. (It is highly recommended that use be limited to SDHC types.) Any particular brand SD card may be used.



SD card operations can only occur while the NXF4000 is in STANDBY or LOCKOUT. NXF4000 units are shipped with a 16GB SDCARD media.

Functions included in the SD operations menu include BACKUP, RESTORE, DELETE and FORMAT. From the top layer menu at the line named SD CARD OPS SETUP press the NEXT key to open up the following sub-menu:

<	S	D		C	A	R	D		O	P	S		S	E	T	U	P		
>	B	A	C	K	U	P													>
	R	E	S	T	O	R	E												>
	D	E	L	E	T	E													>
	F	O	R	M	A	T													>

In order to enter any of the sub menus listed above, an SD card must be installed.

BACKUP OPERATION

The BACKUP function provides options that backup all profiles and setup data collectively, all profiles only, each profile individually or setup data only. Selecting BACKUP with the NEXT key moves to the following sub menu:

<	B	A	C	K	U	P														
>	P	A	R	A	M	E	T	E	R	S		O	N	L	Y				>	
	P	R	O	F	I	L	E	S	,	P	A	R	A	M	E	T	E	R	S	>
	A	L	L		P	R	O	F	I	L	E	S		O	N	L	Y		>	
	P	R	O	F	I	L	E		1		O	N	L	Y					>	
	P	R	O	F	I	L	E		2		O	N	L	Y					>	
	P	R	O	F	I	L	E		3		O	N	L	Y					>	
	P	R	O	F	I	L	E		4		O	N	L	Y					>	



Depending on what BACKUP type is selected, the NXF4000 applies a unique file name and extension that includes the current date (ddmmyy) and time (hhmm) in military format to uniquely identify the file type. To insure accuracy and consistency it is extremely useful to assure the real time clock of the NXF4000 is correctly set prior to any BACKUP operation.

Backup Option	Format	Example
Profiles and Parameters	PFLWddmmyyhhmm.ext	PFLW2206110847.PFW
All profiles only	PFLOddmmyyhhmm.ext	PFLO2206110849.PFO
Individual profiles		
Profile 1	PFL1ddmmyyhhmm.ext	PFL12206110912.PFL
Profile 2	PFL2ddmmyyhhmm.ext	PFL22206111343.PFL
Profile 3	PFL3ddmmyyhhmm.ext	PFL32206111836.PFL
Profile 4	PFL4ddmmyyhhmm.ext	PFL42206112016.PFL
Parameters only	SETPddmmyyhhmm.ext	SETP2206110923.SPD

The BACKUP files are stored on the SD card in a folder named FIREYE. If the folder does not exist, it will be created automatically during the first BACKUP operation. If necessary, any of the files stored on the SD card can be renamed using a PC and a file explorer utility. A unique name of the user's choosing may better describe the application. The length of the file name is limited to 15 characters maximum not including the '.' and the 3 character extension. In order to be restored properly the extension must remain the same as what was assigned by the NXF4000. The file name and extension are not case sensitive.

A BACKUP operation is performed by first inserting an SD card into the slot located in the front of the NXF4000 as shown in FIG 11. The SD card will insert in only one direction so do not apply excessive force. The SD card should 'click' when fully inserted.

Execution of any BACKUP command requires the C-MODE pass code to be enabled. Select the desired BACKUP operation by moving the selection between the two tick marks on the display. Use the UP and DOWN keys as necessary. Press the NEXT key to begin the BACKUP operation. If the pass code is not enabled, the user will be diverted to the pass code screen where the correct C-MODE pass code must be entered. If correct, the BACKUP sub menu will re-appear. The NEXT key is used to begin the BACKUP process. If no SD card is installed the display will indicate:

<	P	R	O	F	I	L	E	S	,	P	A	R	A	M	E	T	E	R	S	>	
>	N	O		S	D		C	A	R	D		I	N	S	T	A	L	L	E	D	<

Otherwise the selected BACKUP operation will be executed and the display will indicate:

<	P	R	O	F	I	L	E	S	,	P	A	R	A	M	E	T	E	R	S	>	
>	I	N		P	R	O	G	R	E	S	.	.	.								<

When complete, the display will indicate:

<	P	R	O	F	I	L	E	S	,	P	A	R	A	M	E	T	E	R	S	>	
>	B	A	C	K	U	P		C	O	M	P	L	E	T	E						<



The NXF4000 performs a read back of the file written to the SD card and if found to be incorrect the display will indicate the failure:

<	P	R	O	F	I	L	E	S	,	P	A	R	A	M	E	T	E	R	S	>
>	I	N	V	A	L	I	D		F	O	R	M	A	T						<
	V	E	R	I	F	Y		F	A	I	L	E	D							
	W	R	I	T	E		P	R	O	T	E	C	T		O	N				
	N	O		S	D		C	A	R	D		I	N	S	T	A	L	L	E	D
	S	D		O	P	E	R	A	T	I	O	N		A	B	O	R	T	E	D

Note: only the single reason for failure is indicated.

The SD card can be removed by pressing lightly on the SD card and then releasing. The SD will eject upward where it can be lifted out of its slot.

At this time the user can press the BACK key to remain in the BACKUP selection sub menu or press the HOME key to exit SD operations.

RESTORE OPERATION

The RESTORE operation is used to restore or replace the current profiles and setup data collectively, all profiles only, any profile individually or setup data only. Note: During any RESTORE operation, FAULT HISTORY is left unchanged.

At the SD CARD OPS SETUP sub menu select the RESTORE function by pressing the NEXT key. The RESTORE sub menu is displayed with the following options:

<	R	E	S	T	O	R	E													>	
>	P	R	O	F	I	L	E	S	,	P	A	R	A	M	E	T	E	R	S	>	<
	A	L	L		P	R	O	F	I	L	E	S		O	N	L	Y			>	
	T	O		P	R	O	F	I	L	E		1								>	
	T	O		P	R	O	F	I	L	E		2								>	
	T	O		P	R	O	F	I	L	E		3								>	
	T	O		P	R	O	F	I	L	E		4								>	
	P	A	R	A	M	E	T	E	R	S		O	N	L	Y					>	

The above listed options are explained as follows:

1. PROFILES & PARAMETERS - restores all profiles and all setup data from a file with extension '.PFW'. All data currently present in the NXF4000 will be overwritten and replaced by the SD card file.
2. ALL PROFILES ONLY - all four profiles in the NXF4000 will be overwritten and replaced from a file extension '.PFO'.
3. TO PROFILE X - restores profile data only to a specific NXF4000 profile (X can be 1, 2, 3 or 4) from a file with extension '.PFL'. Any stored profile data file can be restored to any profile.
4. PARAMETERS ONLY - restores configuration and setup data only from a file with extension '.SPD'. This would include sensor data, setpoint information, servos, digital inputs, keypad data, etc.

To begin the restore operation the user selects the desired restore function and presses the NEXT key. The NXF4000 checks the presence of an SD card installed and then checks the proper C-MODE pass code is enabled and if so the sub menu pertaining to the selected function appears:

<	T	O		P	R	O	F	I	L	E		2								>	
>	P	F	L	1	1	9	0	5	1	1	0	8	4	2	.	P	F	L		>	<
	P	F	L	1	2	0	0	6	1	1	1	0	2	7	.	P	F	L		>	
	P	F	L	2	1	9	0	5	1	1	0	8	4	3	.	P	F	L		>	
	P	F	L	3	1	9	0	5	1	1	0	8	4	4	.	P	F	L		>	
	P	F	L	3	2	2	0	6	1	1	2	0	2	6	.	P	F	L		>	
	P	F	L	4	1	9	0	5	1	1	0	8	4	5	.	P	F	L		>	



As a convenience, only file names with the extension pertaining to the function selected will appear. The UP and DOWN keys are used to scroll downward and upward through the list of files. Files that have been renamed by the user will also appear as long as the extension and file name length are correct.

The user selects the file to be restored and presses NEXT to begin the RESTORE operation. The NXF4000 checks the selected file for validity and if found not be correct the appropriate error message is displayed as previously described. During the RESTORE operation, the display will indicate:

<	T	O		P	R	O	F	I	L	E		2									
>	I	N		P	R	O	G	R	E	S	S	.	.	.							<

When complete the display will indicate:

<	T	O		P	R	O	F	I	L	E		2									
>	R	E	S	T	O	R	E		C	O	M	P	L	E	T	E					<

The SD card can be removed by pressing lightly on the SD card and then releasing. The SD will eject upward where it can be lifted out of its slot.

At this time the user can press the BACK key to remain in the BACKUP selection sub menu or press the HOME key to exit SD operations.

Recommendation: It's strongly advised that a power cycle be applied to the NXF4000 after a RESTORE is done. This would enable all data structures to initialize properly.

DELETE OPERATION

The purpose of DELETE is to allow the user to remove files from the SD card. The files to be removed are files located on the SD card in the FIREYE folder pertaining to the NXF4000 and are identified by the various extensions used.

From the SD CARD OPS SETUP menu the user selects DELETE. The NXF4000 checks the presence of an SD card properly installed and operating then displays the following:

<	D	E	L	E	T	E															
>	P	F	L	1	1	9	0	5	1	1	0	8	4	2	.	P	F	L		>	<
	P	F	L	2	1	9	0	5	1	1	0	8	4	3	.	P	F	L		>	
	P	F	L	3	1	9	0	5	1	1	0	8	4	4	.	P	F	L		>	
	P	F	L	O	1	9	0	5	1	1	0	8	4	6	.	P	F	O		>	
	P	F	L	W	1	9	0	5	1	1	0	8	4	7	.	P	F	W		>	
	S	E	T	P	1	9	0	5	1	1	0	8	4	8	.	S	P	D		>	

The UP and DOWN keys are used to scroll down through the list of files.

The file selected for deletion is moved to between the tick marks. To begin the DELETE operation the user presses the NEXT key. The NXF4000 checks that the proper C-MODE pass code is enabled and if so the DELETE process begins. At the completion the display will indicate the following:

<	D	E	L	E	T	E															
>	D	E	L	E	T	E		C	O	M	P	L	E	T	E						<

The SD card can be removed by pressing lightly on the SD card and then releasing. The SD will eject upward where it can be lifted out of its slot.



At this time the user can press the BACK key to remain in the BACKUP selection sub menu or press the HOME key to exit SD operations.

FORMAT OPERATION

The NXF4000 can be used to format the SD card. The formatting method will only be FAT32. At the FORMAT on the SD OPS SETUP sub menu press NEXT to display the following:

<	F	O	R	M	A	T													
>	D	A	T	A		W	I	L	L		B	E		L	O	S	T		>

Execution of each of the FORMAT command will be activated by pressing the NEXT key. After checking the C-MODE pass code is enabled and an SD card is installed, the formatting process begins. It would not be a good thing to interfere with this operation.

<	F	O	R	M	A	T													
>	F	O	R	M	A	T		I	N		P	R	O	G	R	E	S	S	

At the completion of the formatting process the display indicates the following:

<	F	O	R	M	A	T													
>	F	O	R	M	A	T		C	O	M	P	L	E	T	E				

The SD card can be removed by pressing lightly on the SD card and then releasing. The SD will eject upward where it can be lifted out of its slot.

At this time the user can press the BACK key to remain in the BACKUP selection sub menu or press the HOME key to exit SD operations.

NXF4000 OPERATION AFTER A RESTORE

When a profile only is restored it is possible that data resident in the restored profile is NOT in synchronization with the corresponding parameter data. That is, the number of servos used in the profile may not agree with the number of servos connected to the NXF4000. Also, the addresses and assignment designations in the servo setup may not agree with the data in the profile. Likewise, when parameter data is restored this data may not agree with data that is resident in the stored profiles. For these reasons, after any or all profile only or parameter data only restore operation it will be necessary to enter commissioning mode. Attempting a burner cycle with restored profile or parameter data will result in lockout with the message NOT COMMISSIONED displayed. If profile and parameter data are synchronized then simply press NEXT at each profile setpoint to accept the settings. At the last profile setpoint exit commissioning mode with the C-MODE key. The number of commissioned profile setpoints can be viewed within the INFO screen.

Since a restore operation of PROFILES & PARAMETERS causes all data to be in synchronization, the NXF4000 will be ready to operate. Commissioning with the new data is not necessary but as always the operator should take the necessary steps to assure the restored profile and data settings are adequate for the burner. That is, the actual servo addresses and sensor types agree with the equipment installed.



Profile Setup Work Sheet

Commissioning Date _____

Location _____

Profile# _____

Profile Setpoint	Drive #					VFD#	OXYGEN		STACK	CO	Net Eff
	Name						LEVEL		TEMP		
	CW	<input type="checkbox"/>	<input type="checkbox"/>	<input type="checkbox"/>	<input type="checkbox"/>	%FS	Wet	Dry			
	CCW	<input type="checkbox"/>	<input type="checkbox"/>	<input type="checkbox"/>	<input type="checkbox"/>	CNTS					
		(°)	(°)	(°)	(°)	ENCODE			°F / °C	PPM	
p00											
p01											
p02											
p03											
p04											
p05											
p06											
p07											
p08											
p09											
p10											
p11											
p12											
p13											
p14											
p15											
p16											
p17											
p18											
p19											
p20											
p21											
p22											
p23											

Notes:

Setpoint	
Cut-in	
Cut-out	
P-Band	
Integral	
Derivative	

Boiler Manuf.	
Boiler Type	
Boiler Size	
Burner Type	
Burner Size	
Ambient Temp.	



Profile Setup Work Sheet

Commissioning Date _____

Location _____

Profile# _____

Profile Setpoint	Drive #					VFD#	OXYGEN		STACK	CO	Net Eff
	Name						LEVEL		TEMP		
	CW	<input type="checkbox"/>	<input type="checkbox"/>	<input type="checkbox"/>	<input type="checkbox"/>	%FS	Wet	Dry			
	CCW	<input type="checkbox"/>	<input type="checkbox"/>	<input type="checkbox"/>	<input type="checkbox"/>	CNTS			°F / °C	PPM	
	(°)	(°)	(°)	(°)	ENCODE						
p00											
p01											
p02											
p03											
p04											
p05											
p06											
p07											
p08											
p09											
p10											
p11											
p12											
p13											
p14											
p15											
p16											
p17											
p18											
p19											
p20											
p21											
p22											
p23											

Notes:

Setpoint	
Cut-in	
Cut-out	
P-Band	
Integral	
Derivative	

Boiler Manuf.	
Boiler Type	
Boiler Size	
Burner Type	
Burner Size	
Ambient Temp.	

LOCKOUTS:

When a safety shutdown occurs, the control will indicate the reason for the lockout through the Alarm relay and also describe the lockout on the User Interface. The alarm relay located on terminals P4.1 to P4.2 will be energized. The non-volatile memory will remember the status (Run or Lockout) of the control even if a power failure occurs. By momentarily depressing and releasing the reset button located on the User Interface or through a programmable digital input, the control can be reset. The button must be held down for one second and then released. Very little force is required to do this. Do not press hard.



NOTICE: Regulation prohibits the system from allowing more than 5 reset attempts in a 15-minute window. If 5 reset attempts are made without addressing the lockout, the system will prevent the user from issuing additional resets and it will force the user to wait for the balance of 15 minutes. Reset operation will be restored after the wait period. It is expected that a qualified personnel assess the lockout condition and apply the proper remedy to address the lockout. A single reset attempt is usually enough to restore normal system operation.

The action of a lockout will cause the safety relay output located at terminal P5.10 to be de-energized thus opening the non-recycling interlock in the flame safeguard circuit. This is followed by all other relays in the NXF4000 moving to a de-energized state.



ERROR MESSAGES:

The following list provides error codes and explanations to help people in the field respond more effectively to issues that arise.

Error Code	Displayed	Reason for error	Possible remedy
e1	NXF4000 FAULT	ARM CPU self-test	Replace NXF4000
e2	NXF4000 FAULT	ARM CPU code CRC	Replace NXF4000
e3	Z BOARD FAULT	NXF4000 cannot communicate with the Z board	Check or replace Z board
e4	SAFETY RELAY ON	User supplying line voltage to terminal	Check wiring to specific terminal
e5	SAFETY RELAY OFF	No line voltage on terminal	Check Fuse
e6	RELAY 8 ON	User supplying line voltage to terminal	Check wiring to specific terminal
e7	RELAY 8 OFF	NXF4000 Internal Error	Replace NXF4000
e8	RELAY D ON	User supplying line voltage to terminal	Check wiring to specific terminal
e9	RELAY D OFF	NXF4000 Internal Error	Replace NXF4000
e10	NXF4000 FAULT	Unused	
e11	INVALID PROFILE	The user is supplying line voltage to more than 1 of the following P15-5,6,7,8	Check wiring
e12	HIGH TEMPERATURE	Internal Temperature is above 80C	Check Fan or provide better ventilation
e13	CHECK WIRING	User supplying line voltage to terminal to more than one of the following terminals at one time: P15-2,3,4	Check wiring
e14	CHECK WIRING	User has not connected one or more of the following terminals: P15-2,3,4	Check wiring
e15	NO AIR SERVO	The user has no servo named "AIR" in the current profile	Name one servo in current profile "AIR"
e16	NO FUEL SERVO	The user has no servo in the current profile with one of these names: FU1,FU2,GAS,OIL,CUP,PUM,WAS,PRI	Name one servo in current profile as a fuel servo
e17	INVALID SETPOINT	User has not configured setpoint 2 to be using sensor 1	Configure setpoint 2 to use sensor 1
e18	NXF4000 FAULT	Unused	
e19	SENSOR 1 MARGINAL	SENSOR 1 has reached user defined marginal setting	This could be normal operation
e20	SENSOR 1 MARGINAL	SENSOR 1 has reached user defined marginal setting	This could be normal operation
e21	SENSOR 2 MARGINAL	SENSOR 2 has reached user defined marginal setting	This could be normal operation
e22	SENSOR 2 MARGINAL	SENSOR 2 has reached user defined marginal setting	This could be normal operation
e23	SENSOR 2 MARGINAL	SENSOR 2 has reached user defined marginal setting	This could be normal operation
e24	SENSOR 3 MARGINAL	SENSOR 3 has reached user defined marginal setting	This could be normal operation
e25	SENSOR 3 MARGINAL	SENSOR 3 has reached user defined marginal setting	This could be normal operation
e26	SENSOR 3 MARGINAL	SENSOR 3 has reached user defined marginal setting	This could be normal operation
e27	SENSOR1 HIGH LIMIT	SENSOR 1 has reached user defined limit setting	This could be normal operation
e28	SENSOR1 HIGH LIMIT	SENSOR 1 has reached user defined limit setting	This could be normal operation
e29	SENSOR2 HIGH LIMIT	SENSOR 2 has reached user defined limit setting	This could be normal operation
e30	SENSOR2 HIGH LIMIT	SENSOR 2 has reached user defined limit setting	This could be normal operation
e31	SENSOR2 HIGH LIMIT	SENSOR 2 has reached user defined limit setting	This could be normal operation
e32	SENSOR3 HIGH LIMIT	SENSOR 3 has reached user defined limit setting	This could be normal operation
e33	SENSOR3 HIGH LIMIT	SENSOR 3 has reached user defined limit setting	This could be normal operation
e34	SENSOR3 HIGH LIMIT	SENSOR 3 has reached user defined limit setting	This could be normal operation
e35	SENSOR1 UNDER RNG	SENSOR 1 input is under 2mA	Defective sensor or check wiring
e36	SENSOR1 OVER RNG	SENSOR 1 input is over 22mA	Defective sensor or check wiring
e37	SENSOR2 UNDER RNG	SENSOR 2 input is under 2mA	Defective sensor or check wiring
e38	SENSOR2 OVER RNG	SENSOR 2 input is over 22mA	Defective sensor or check wiring
e39	SENSOR3 UNDER RNG	SENSOR 3 input is under 2mA	Defective sensor or check wiring
e40	SENSOR3 OVER RNG	SENSOR 3 input is over 22mA	Defective sensor or check wiring
e41	Z BOARD	Z Board internal error	Replace Z Board
e42	Z BOARD	Z Board internal error	Replace Z Board
e43	NXF4000 FAULT	NXF4000 Internal Error	Replace NXF4000 (notify Fireye about this error)
e44	NXF4000 FAULT	NXF4000 Internal Error	Replace NXF4000 (notify Fireye about this error)
e45	NXF4000 FAULT	NXF4000 Internal Error	Replace NXF4000 (notify Fireye about this error)
e46	O2 FAULT	O2 Probe NXF4000 FAULT	Replace O2 Probe
e47	O2 FAULT	O2 is not communicating with the NXF4000	Check Wiring or add 200 Ohm resistor
e48	O2 FAULT	O2 Probe is reporting that the O2 level is below the user configured minimum	This could be normal operation
e49	O2 FAULT	O2 Probe is reporting that the O2 level is above the user configured maximum	This could be normal operation
e50	O2 FAULT	O2 Probe is reporting that the stack temperature is below the user configured minimum	This could be normal operation



Error Code	Displayed	Reason for error	Possible remedy
e51	O2 FAULT	O2 Probe is reporting that the stack temperature is above the user configured maximum	This could be normal operation
e52	O2 FAULT	O2 Probe NXF4000 FAULT	Replace O2 Probe
e53	O2 FAULT	O2 Probe NXF4000 FAULT	Replace O2 Probe
e54	O2 FAULT	O2 thermocouple is disconnected or defective	Check thermocouple for breakage or replace it
e55	O2 FAULT	O2 stack temperature is above the user configurable temperature or thermocouple is defective	This could be normal operation
e56	O2 FAULT	O2 stack temperature is below 0 Celsius or thermocouple is defective	This could be normal operation
e57	O2 FAULT	O2 Probe NXF4000 FAULT	Replace O2 Probe
e58	O2 FAULT	O2 probe temperature is above 85 Celsius	Check O2 Probe fan
e59	O2 FAULT	O2 probe temperature is below -25 Celsius	This could be normal operation if it is really cold
e60	O2 FAULT	O2 Probe NXF4000 FAULT	Replace O2 Probe
e61	O2 FAULT	O2 Probe NXF4000 FAULT	Replace O2 Probe
e62	O2 FAULT	O2 Probe NXF4000 FAULT	Replace O2 Probe
e63	O2 FAULT	The 24V supply to the O2 probe is under	Measure supply voltage at the probe
e64	O2 FAULT	The 24V supply to the O2 probe is over	Measure supply voltage at the probe
e65	O2 FAULT	O2 Probe 12V supply open	Replace O2 Probe
e66	O2 FAULT	O2 Probe 12V supply low	Replace O2 Probe
e67	O2 FAULT	O2 Probe 12V supply high	Replace O2 Probe
e68	O2 FAULT	O2 Probe unexpected calibration fault	Replace O2 Probe cartridge
e69	O2 FAULT	O2 Probe stuck	Replace O2 Probe cartridge
e70	O2 FAULT	O2 Probe calibration needed	This could be normal operation
e71	O2 FAULT	O2 Probe heater shorted	Replace O2 Probe cartridge
e72	O2 FAULT	O2 Probe heater open	Replace O2 Probe cartridge
e73	O2 FAULT	O2 Probe pump short	Replace O2 Probe cartridge
e74	O2 FAULT	O2 Probe pump open	Replace O2 Probe cartridge
e75	O2 FAULT	O2 Probe nernst cell short	Replace O2 Probe cartridge
e76	O2 FAULT	O2 Probe nernst cell open	Replace O2 Probe cartridge
e77	O2 FAULT	O2 Probe conversion timeout	Replace O2 Probe cartridge
e78	O2 FAULT	O2 Probe low voltage	Replace O2 Probe cartridge
e79	O2 FAULT	O2 Probe too cold	Replace O2 Probe cartridge
e80	O2 FAULT	O2 Probe too hot	Replace O2 Probe cartridge
e81	O2 FAULT	O2 Probe air calibration	Replace O2 Probe cartridge
e82	O2 FAULT	O2 Probe heater calibration	Replace O2 Probe cartridge
e83	O2 FAULT	O2 Probe comm busy	Replace O2 Probe cartridge
e84	O2 FAULT	O2 Probe comm fault	Replace O2 Probe cartridge
e85	O2 FAULT	O2 Probe Sensor warming up	This could be normal operation
e86	O2 FAULT	O2 Probe sensor in standby	This could be normal operation
e87	NXF4000 FAULT	Unused	
e88	NXF4000 FAULT	NXF4000 Internal Error	Replace NXF4000 (notify Fireye about this error)
e89	NOT COMMISSIONED	User has less than 3 points in the current profile	Recommission current profile
e90	NXF4000 FAULT	FRAM chip may be bad	Replace NXF4000
e91	NXF4000 FAULT	Helper CPU may not be programmed	Replace NXF4000 (notify Fireye about this error)
e92	NXF4000 FAULT	Unused	
e93	NXF4000 FAULT	The main and helper CPUs are not communicating or clock error	Replace NXF4000
e94	NXF4000 FAULT	Helper CPU internal error 1	Replace NXF4000
e95	NXF4000 FAULT	Helper CPU internal error 2	Replace NXF4000
e96	NXF4000 FAULT	Helper CPU internal error 3	Replace NXF4000
e97	NXF4000 FAULT	Helper CPU internal error 4	Replace NXF4000
e98	NXF4000 FAULT	The main and helper CPUs are not communicating	Replace NXF4000
e99	NXF4000 FAULT	Helper CPU ROM CRC not correct	Replace NXF4000
e100	NXF4000 FAULT	Helper CPU optocoupler input pin stuck-at-fault	Replace NXF4000
e101	NXF4000 FAULT	Helper CPU optocoupler input pin to pin short	Replace NXF4000
e102	NXF4000 FAULT	Helper CPU is not running	Replace NXF4000
e103	NXF4000 FAULT	Unused	
e104 - e121	NXF4000 FAULT	NXF4000 Internal Error	Replace NXF4000 (notify Fireye about this error)
e122	SERVO 1 LOST	Communications to the servo has stopped	In this order: check servo address selection, check wiring, add 200 resistor, replace servo.
e123	SERVO 2 LOST	Communications to the servo has stopped	In this order: check servo address selection, check wiring, add 200 resistor, replace servo.
e124	SERVO 3 LOST	Communications to the servo has stopped	In this order: check servo address selection, check wiring, add 200 resistor, replace servo.
e125	SERVO 4 LOST	Communications to the servo has stopped	In this order: check servo address selection, check wiring, add 200 resistor, replace servo.



Error Code	Displayed	Reason for error	Possible remedy
e126	SERVO 5 LOST	Communications to the servo has stopped	In this order: check servo address selection, check wiring, add 200 resistor, replace servo.
e127	SERVO 6 LOST	Communications to the servo has stopped	In this order: check servo address selection, check wiring, add 200 resistor, replace servo.
e128	SERVO 7 LOST	Communications to the servo has stopped	In this order: check servo address selection, check wiring, add 200 resistor, replace servo.
e129	SERVO 8 LOST	Communications to the servo has stopped	In this order: check servo address selection, check wiring, add 200 resistor, replace servo.
e130	SERVO 9 LOST	Communications to the servo has stopped	In this order: check servo address selection, check wiring, add 200 resistor, replace servo.
e131	SERVO 10 LOST	Communications to the servo has stopped	In this order: check servo address selection, check wiring, add 200 resistor, replace servo.
e132 - e141	NXF4000 FAULT	Unused	
e142	SERVO 1 STUCK	Expected shaft movement does not equal measured shaft movement	In this order: Excessive torque, servo hitting hard stop, defective servo.
e143	SERVO 2 STUCK	Expected shaft movement does not equal measured shaft movement	In this order: Excessive torque, servo hitting hard stop, defective servo.
e144	SERVO 3 STUCK	Expected shaft movement does not equal measured shaft movement	In this order: Excessive torque, servo hitting hard stop, defective servo.
e145	SERVO 4 STUCK	Expected shaft movement does not equal measured shaft movement	In this order: Excessive torque, servo hitting hard stop, defective servo.
e146	SERVO 5 STUCK	Expected shaft movement does not equal measured shaft movement	In this order: Excessive torque, servo hitting hard stop, defective servo.
e147	SERVO 6 STUCK	Expected shaft movement does not equal measured shaft movement	In this order: Excessive torque, servo hitting hard stop, defective servo.
e148	SERVO 7 STUCK	Expected shaft movement does not equal measured shaft movement	In this order: Excessive torque, servo hitting hard stop, defective servo.
e149	SERVO 8 STUCK	Expected shaft movement does not equal measured shaft movement	In this order: Excessive torque, servo hitting hard stop, defective servo.
e150	SERVO 9 STUCK	Expected shaft movement does not equal measured shaft movement	In this order: Excessive torque, servo hitting hard stop, defective servo.
e151	SERVO 10 STUCK	Expected shaft movement does not equal measured shaft movement	In this order: Excessive torque, servo hitting hard stop, defective servo.
e152 - e161	NXF4000 FAULT	Unused	
e162	SERVO 1 ERROR	Servo has detected an NXF4000 FAULT	Replace servo
e163	SERVO 2 ERROR	Servo has detected an NXF4000 FAULT	Replace servo
e164	SERVO 3 ERROR	Servo has detected an NXF4000 FAULT	Replace servo
e165	SERVO 4 ERROR	Servo has detected an NXF4000 FAULT	Replace servo
e166	SERVO 5 ERROR	Servo has detected an NXF4000 FAULT	Replace servo
e167	SERVO 6 ERROR	Servo has detected an NXF4000 FAULT	Replace servo
e168	SERVO 7 ERROR	Servo has detected an NXF4000 FAULT	Replace servo
e169	SERVO 8 ERROR	Servo has detected an NXF4000 FAULT	Replace servo
e170	SERVO 9 ERROR	Servo has detected an NXF4000 FAULT	Replace servo
e171	SERVO 10 ERROR	Servo has detected an NXF4000 FAULT	Replace servo
e172 - e181	NXF4000 FAULT	Unused	
e182	SERVO 1 VOLTAGE	Voltage supply to servo is above 33V	Excessive voltage to servo or defective servo
e183	SERVO 2 VOLTAGE	Voltage supply to servo is above 33V	Excessive voltage to servo or defective servo
e184	SERVO 3 VOLTAGE	Voltage supply to servo is above 33V	Excessive voltage to servo or defective servo
e185	SERVO 4 VOLTAGE	Voltage supply to servo is above 33V	Excessive voltage to servo or defective servo
e186	SERVO 5 VOLTAGE	Voltage supply to servo is above 33V	Excessive voltage to servo or defective servo
e187	SERVO 6 VOLTAGE	Voltage supply to servo is above 33V	Excessive voltage to servo or defective servo
e188	SERVO 7 VOLTAGE	Voltage supply to servo is above 33V	Excessive voltage to servo or defective servo
e189	SERVO 8 VOLTAGE	Voltage supply to servo is above 33V	Excessive voltage to servo or defective servo
e190	SERVO 9 VOLTAGE	Voltage supply to servo is above 33V	Excessive voltage to servo or defective servo
e191	SERVO 10 VOLTAGE	Voltage supply to servo is above 33V	Excessive voltage to servo or defective servo
e192 - e201	NXF4000 FAULT	Unused	
e202	SERVO 1 VOLTAGE	Voltage supply to servo is below 21.4V	Insufficient voltage to servo under load or defective servo
e203	SERVO 2 VOLTAGE	Voltage supply to servo is below 21.4V	Insufficient voltage to servo under load or defective servo
e204	SERVO 3 VOLTAGE	Voltage supply to servo is below 21.4V	Insufficient voltage to servo under load or defective servo
e205	SERVO 4 VOLTAGE	Voltage supply to servo is below 21.4V	Insufficient voltage to servo under load or defective servo
e206	SERVO 5 VOLTAGE	Voltage supply to servo is below 21.4V	Insufficient voltage to servo under load or defective servo
e207	SERVO 6 VOLTAGE	Voltage supply to servo is below 21.4V	Insufficient voltage to servo under load or defective servo
e208	SERVO 7 VOLTAGE	Voltage supply to servo is below 21.4V	Insufficient voltage to servo under load or defective servo
e209	SERVO 8 VOLTAGE	Voltage supply to servo is below 21.4V	Insufficient voltage to servo under load or defective servo
e210	SERVO 9 VOLTAGE	Voltage supply to servo is below 21.4V	Insufficient voltage to servo under load or defective servo
e211	SERVO 10 VOLTAGE	Voltage supply to servo is below 21.4V	Insufficient voltage to servo under load or defective servo
e212 - e221	NXF4000 FAULT	Unused	



Error Code	Displayed	Reason for error	Possible remedy
e222	SERVO 1 OFF RATIO	Servo may have exceeded its torque capacity	In this order: Excessive torque, position hitting hard stop, defective servo.
e223	SERVO 2 OFF RATIO	Servo may have exceeded its torque capacity	In this order: Excessive torque, position hitting hard stop, defective servo.
e224	SERVO 3 OFF RATIO	Servo may have exceeded its torque capacity	In this order: Excessive torque, position hitting hard stop, defective servo.
e225	SERVO 4 OFF RATIO	Servo may have exceeded its torque capacity	In this order: Excessive torque, position hitting hard stop, defective servo.
e226	SERVO 5 OFF RATIO	Servo may have exceeded its torque capacity	In this order: Excessive torque, position hitting hard stop, defective servo.
e227	SERVO 6 OFF RATIO	Servo may have exceeded its torque capacity	In this order: Excessive torque, position hitting hard stop, defective servo.
e228	SERVO 7 OFF RATIO	Servo may have exceeded its torque capacity	In this order: Excessive torque, position hitting hard stop, defective servo.
e229	SERVO 8 OFF RATIO	Servo may have exceeded its torque capacity	In this order: Excessive torque, position hitting hard stop, defective servo.
e230	SERVO 9 OFF RATIO	Servo may have exceeded its torque capacity	In this order: Excessive torque, position hitting hard stop, defective servo.
e231	SERVO 10 OFF RATIO	Servo may have exceeded its torque capacity	In this order: Excessive torque, position hitting hard stop, defective servo.
e232 - e241	NXF4000 FAULT	Unused	
e242	NXF4000 FAULT	NXF4000 Internal 24V supply to high	Replace NXF4000
e243	NXF4000 FAULT	NXF4000 Internal 24V supply to low	Replace NXF4000
e244	NXF4000 FAULT	NXF4000 Internal 5V supply to high	Replace NXF4000
e245	NXF4000 FAULT	NXF4000 Internal 5V supply to low	Replace NXF4000
e246	NXF4000 FAULT	Main processor failure	Replace NXF4000
e247	NXF4000 FAULT	Main processor failure	Replace NXF4000
e248	NXF4000 FAULT	Main processor failure	Replace NXF4000
e249	NXF4000 FAULT	External watchdog timer malfunction	Replace NXF4000
e250	NXF4000 FAULT	NXF4000 Internal Error	Replace NXF4000
e251	SENSOR4 UNDER RNG	PCV input is under 2mA	Defective sensor or check wiring
e252	SENSOR4 OVER RNG	PCV input is over 22mA	Defective sensor or check wiring
e253	SENSOR4 UNDER RNG	PCV input is under 2mA	Defective sensor or check wiring
e254	SENSOR4 OVER RNG	PCV input is over 22mA	Defective sensor or check wiring
e255	NOT COMMISSIONED	User restored a file from the SD card that has not been verified	Recommission current profile
e256	VFD1 OFF RATIO	VFD input 1 is moving too slow to meet timeout	Check VFD for proper setup
e257	VFD2 OFF RATIO	VFD input 2 is moving too slow to meet timeout	Check VFD for proper setup
e258	VFD COMM FAULT 1	VFD Board is missing or CPU is not programmed	Replace VFD Board
e259	VFD COMM FAULT 2	VFD Board communication problem	Replace VFD Board or NXF4000
e260	VFD1 MISSING	VFD was commissioned to current profile but is not available	Replace VFD Board or fix VFD 1 use in setup
	VFD2 MISSING	VFD was commissioned to current profile but is not available	Replace VFD Board or fix VFD 2 use in setup
e262	NXF4000 FAULT	Unused	
e263	NXF4000 FAULT	Unused	
e264	NXF4000 FAULT	Unused	
e265	NXF4000 FAULT	Unused	
e266	VFD BOARD FAULT	VFD Board CPU error	Replace VFD Board
e267	VFD BOARD FAULT	VFD Board CPU error	Replace VFD Board
e268	VFD BOARD FAULT	VFD Board CPU error	Replace VFD Board
e269	VFD BOARD FAULT	VFD Board CPU error	Replace VFD Board
e270	VFD BOARD FAULT	VFD Board CPU error	Replace VFD Board
e271	VFD BOARD FAULT	VFD Board CPU error	Replace VFD Board
e272	VFD1 INPUT BELOW 4mA	VFD 1 input is less than 2 mA	Defective input or check wiring
e273	VFD BOARD FAULT	VFD Board CPU error	Replace VFD Board
e274	VFD BOARD FAULT	VFD Board CPU error	Replace VFD Board
e275	VFD BOARD FAULT	VFD Board CPU error	Replace VFD Board
e276	VFD BOARD FAULT	VFD Board has not been calibrated	Replace VFD Board
e277	VFD BOARD FAULT	VFD Board CPU error	Replace VFD Board
e278	VFD2 INPUT BELOW 4mA	VFD 2 input is less than 2 mA	Defective input or check wiring
e279	VFD BOARD FAULT	VFD Board CPU error	Replace VFD Board
e280	VFD BOARD FAULT	VFD Board communication problem	Replace VFD Board or NXF4000
e281	CHECK VFD1 INPUT	VFD 1 input is either under 2mA either over 21mA	Defective input or check wiring
e282	CHECK VFD2 INPUT	VFD 2 input is either under 2mA either over 21mA	Defective input or check wiring
e283	P0 NOT COMMISSIONED	p00 not commissioned	Commission the p00 servo positions
e284	MAIN CPU FAULT 1	NXF4000 main CPU timing error	Replace NXF4000 (notify Fireye about this error)



Error Code	Displayed	Reason for error	Possible remedy
e285	MAIN CPU FAULT 2	NXF4000 main CPU timing error	Replace NXF4000 (notify Fireye about this error)
e286	MAIN CPU FAULT 3	NXF4000 main CPU timing error	Replace NXF4000 (notify Fireye about this error)
e287	MAIN CPU FAULT 4	NXF4000 main CPU timing error	Replace NXF4000 (notify Fireye about this error)
e288	MAIN CPU FAULT 5	NXF4000 main CPU timing error	Replace NXF4000 (notify Fireye about this error)
e289	MAIN CPU FAULT 6	NXF4000 main CPU timing error	Replace NXF4000 (notify Fireye about this error)
e290	MAIN CPU FAULT 7	NXF4000 main CPU timing error	Replace NXF4000 (notify Fireye about this error)
e291	LESS THAN 2 SERVOS	Less than 2 servos have been assigned to the current profile	Assign at least to servos (at least one AIR and one Fuel) to the profiles being used.
e292	UNIT TEMP SENSORS	The two internal temperature sensors disagree by more than 6 degrees Celsius	Replace NXF4000
e293	Not commissioned	User changed the fuel type used to commission this profile by changing the profile's name	Recommission current profile or restore backup
e294 - e318	NXF4000 FAULT	Unused	
e319	NO SENSOR-SETPT DATA	Stored "sensor data" is corrupted	Pressing RESET will restore factory default values
e320	NO SERVO SETUP DATA	Stored "servo data" is corrupted	Pressing RESET will restore factory default values
e321	NO DIG I/P DATA	Stored "di data" is corrupted	Pressing RESET will restore factory default values
e322	NO PASSCODE DATA	Stored "passcode data" is corrupted	Pressing RESET will restore factory default values
e323	NO P0 DATA	Stored "p0 data" is corrupted	Pressing RESET will restore factory default values
e324	NO PROFILE1 DATA	Stored "profile 1 data" is corrupted	Pressing RESET will restore factory default values
e325	NO PROFILE2 DATA	Stored "profile 2 data" is corrupted	Pressing RESET will restore factory default values
e326	NO PROFILE3 DATA	Stored "profile 3 data" is corrupted	Pressing RESET will restore factory default values
e327	NO PROFILE4 DATA	Stored "profile 4 data" is corrupted	Pressing RESET will restore factory default values
e328	NO PROFL SETUP DATA	Stored "profile setup data" is corrupted	Pressing RESET will restore factory default values
e329	NO KEYPAD SETUP DATA	Stored "keypad setup data" is corrupted	Pressing RESET will restore factory default values
e330	NO KEY STATES DATA	Stored "key states data" is corrupted	Pressing RESET will restore factory default values
e331	NO THERML SHOCK DATA	Stored "thermal shock data" is corrupted	Pressing RESET will restore factory default values
e332	NO FAULT HISTRY DATA	Stored "fault history data" is corrupted	Pressing RESET will restore factory default values
e333	NO SETBACK DATA	Stored "setback data" is corrupted	Pressing RESET will restore factory default values
e334	NO COMM SETUP DATA	Stored "communication data" is corrupted	Pressing RESET will restore factory default values
e335	NO SEQUENCING DATA	Stored "sequencing data" is corrupted	Pressing RESET will restore factory default values
e336	NO O2 SETUP DATA	Stored "o2 setup data" is corrupted	Pressing RESET will restore factory default values
e337	NO ADJUSTED O2 DATA	Stored "adjusted o2 data" is corrupted	Pressing RESET will restore factory default values
e338	NO ANALOG OUT DATA	Stored "analog out data" is corrupted	Pressing RESET will restore factory default values
e339	NO VFD SETUP DATA	Stored "vfd setup data" is corrupted	Pressing RESET will restore factory default values
e340	NO VFD PROFILE1 DATA	Stored "vfd profile 1 data" is corrupted	Pressing RESET will restore factory default values
e341	NO VFD PROFILE2 DATA	Stored "vfd profile 2 data" is corrupted	Pressing RESET will restore factory default values
e342	NO VFD PROFILE3 DATA	Stored "vfd profile 3 data" is corrupted	Pressing RESET will restore factory default values
e343	NO VFD PROFILE4 DATA	Stored "vfd profile 4 data" is corrupted	Pressing RESET will restore factory default values
e344	NO BURNER DATA	"Burner Info data" is corrupted (FSG only)	Pressing RESET will restore factory default values
e345	NO FSG SETUP DATA	"FSG Setup data" is corrupted (FSG only)	Pressing RESET will restore factory default values
e346	NO FSG DI DATA	"FSG DI data" is corrupted (FSG only)	Pressing RESET will restore factory default values
e347	NO VALVE PROV DATA	"Valve Proving data" is corrupted (FSG only)	Pressing RESET will restore factory default values
e348	NO USER OUTPUT DATA	"User Output data" is corrupted (FSG only)	Pressing RESET will restore factory default values
e349	NO CO SETUP DATA	"co setup data" is corrupted (Future use)	Pressing RESET will restore factory default values
e350 - e368	NXF4000 FAULT	Unused	
e369	NXF4000 FAULT	"sensor data" is corrupted	Pressing RESET will restore values from stored memory
e370	NXF4000 FAULT	"servo data" is corrupted	Pressing RESET will restore values from stored memory
e371	NXF4000 FAULT	"di data" is corrupted	Pressing RESET will restore values from stored memory
e372	NXF4000 FAULT	"passcode data" is corrupted	Pressing RESET will restore values from stored memory
e373	NXF4000 FAULT	"p0 data" is corrupted	Pressing RESET will restore values from stored memory
e374	NXF4000 FAULT	"profile 1 data" is corrupted	Pressing RESET will restore values from stored memory
e375	NXF4000 FAULT	"profile 2 data" is corrupted	Pressing RESET will restore values from stored memory
e376	NXF4000 FAULT	"profile 3 data" is corrupted	Pressing RESET will restore values from stored memory
e377	NXF4000 FAULT	"profile 4 data" is corrupted	Pressing RESET will restore values from stored memory
e378	NXF4000 FAULT	"profile setup data" is corrupted	Pressing RESET will restore values from stored memory
e379	NXF4000 FAULT	"keypad setup data" is corrupted	Pressing RESET will restore values from stored memory
e380	NXF4000 FAULT	"key states data" is corrupted	Pressing RESET will restore values from stored memory
e381	NXF4000 FAULT	"thermal shock data" is corrupted	Pressing RESET will restore values from stored memory
e382	NXF4000 FAULT	"fault history data" is corrupted	Pressing RESET will restore values from stored memory
e383	NXF4000 FAULT	"setback data" is corrupted	Pressing RESET will restore values from stored memory
e384	NXF4000 FAULT	"communication data" is corrupted	Pressing RESET will restore values from stored memory
e385	NXF4000 FAULT	"sequencing data" is corrupted	Pressing RESET will restore values from stored memory
e386	NXF4000 FAULT	"o2 setup data" is corrupted	Pressing RESET will restore values from stored memory
e387	NXF4000 FAULT	"adjusted o2 data" is corrupted	Pressing RESET will restore values from stored memory
e388	NXF4000 FAULT	"analog out data" is corrupted	Pressing RESET will restore values from stored memory
e389	NXF4000 FAULT	"vfd setup data" is corrupted	Pressing RESET will restore values from stored memory
e390	NXF4000 FAULT	"vfd profile 1 data" is corrupted	Pressing RESET will restore values from stored memory



Error Code	Displayed	Reason for error	Possible remedy
e391	NXF4000 FAULT	"vfd profile 2 data" is corrupted	Pressing RESET will restore values from stored memory
e392	NXF4000 FAULT	"vfd profile 3 data" is corrupted	Pressing RESET will restore values from stored memory
e393	NXF4000 FAULT	"vfd profile 4 data" is corrupted	Pressing RESET will restore values from stored memory
e394	NXF4000 FAULT	"Burner Info data" is corrupted	Pressing RESET will restore values from stored memory
e395	NXF4000 FAULT	"FSG Setup data" is corrupted	Pressing RESET will restore values from stored memory
e396	NXF4000 FAULT	"FSG DI data" is corrupted	Pressing RESET will restore values from stored memory
e397	NXF4000 FAULT	"Valve Proving data" is corrupted	Pressing RESET will restore values from stored memory
e398	NXF4000 FAULT	"User Output data" is corrupted	Pressing RESET will restore values from stored memory
e399	NXF4000 FAULT	"CO Setup data" is corrupted (Future use)	Pressing RESET will restore values from stored memory
e400 - e418	NXF4000 FAULT	Unused	
e419	CANNOT MOVE TO PURGE	Cannot move to PURGE (P1) in allotted time	
e420	NXF4000 FAULT	Manual move button pressed on servo 1	Inspect Servo for button obstruction (wires touching)
e421	NXF4000 FAULT	Manual move button pressed on servo 2	Inspect Servo for button obstruction (wires touching)
e422	NXF4000 FAULT	Manual move button pressed on servo 3	Inspect Servo for button obstruction (wires touching)
e423	NXF4000 FAULT	Manual move button pressed on servo 4	Inspect Servo for button obstruction (wires touching)
e424	NXF4000 FAULT	Manual move button pressed on servo 5	Inspect Servo for button obstruction (wires touching)
e425	NXF4000 FAULT	Manual move button pressed on servo 6	Inspect Servo for button obstruction (wires touching)
e426	NXF4000 FAULT	Manual move button pressed on servo 7	Inspect Servo for button obstruction (wires touching)
e427	NXF4000 FAULT	Manual move button pressed on servo 8	Inspect Servo for button obstruction (wires touching)
e428	NXF4000 FAULT	Manual move button pressed on servo 9	Inspect Servo for button obstruction (wires touching)
e429	NXF4000 FAULT	Manual move button pressed on servo 10	Inspect Servo for button obstruction (wires touching)
e430	FVES OPEN i01	FVES Open on DI 1	
e431	FVES OPEN i02	FVES Open on DI 2	
e432	FVES OPEN i03	FVES Open on DI 3	
e433	FVES OPEN i04	FVES Open on DI 4	
e434	FVES OPEN i05	FVES Open on DI 5	
e435	FVES OPEN i06	FVES Open on DI 6	
e436	FVES OPEN i07	FVES Open on DI 7	
e437	FVES OPEN i08	FVES Open on DI 8	
e438	FVES OPEN i09	FVES Open on DI 9	
e439	FVES OPEN i10	FVES Open on DI 10	
e440	FVES OPEN i11	FVES Open on DI 11	
e441	FVES OPEN i12	FVES Open on DI 12	
e442	FVES OPEN i13	FVES Open on DI 13	
e443	FVES OPEN i14	FVES Open on DI 14	
e444	FVES OPEN i15	FVES Open on DI 15	
e445	FVES OPEN i16	FVES Open on DI 16	
e446	FVES CLOSED i01	FVES Closed on DI 1	
e447	FVES CLOSED i02	FVES Closed on DI 2	
e448	FVES CLOSED i03	FVES Closed on DI 3	
e449	FVES CLOSED i04	FVES Closed on DI 4	
e450	FVES CLOSED i05	FVES Closed on DI 5	
e451	FVES CLOSED i06	FVES Closed on DI 6	
e452	FVES CLOSED i07	FVES Closed on DI 7	
e453	FVES CLOSED i08	FVES Closed on DI 8	
e454	FVES CLOSED i09	FVES Closed on DI 9	
e455	FVES CLOSED i10	FVES Closed on DI 10	
e456	FVES CLOSED i11	FVES Closed on DI 11	
e457	FVES CLOSED i12	FVES Closed on DI 12	
e458	FVES CLOSED i13	FVES Closed on DI 13	
e459	FVES CLOSED i14	FVES Closed on DI 14	
e460	FVES CLOSED i15	FVES Closed on DI 15	
e461	FVES CLOSED i16	FVES Closed on DI 16	
e462	LOST P INPUT	Non-Recycle input (P5.10) is open	Check wiring, safety interlocks, limit chain
e463	NXF4000 FAULT	Start of FSG only faults	
e464	PILOT RELAY ON	PILOT Relay ON	
e465	IGNITE RELAY ON	IGNITE Relay ON	
e466	OIL RELAY ON	OIL Relay ON	
e467	GV1 RELAY ON	GV1 Relay ON	
e468	GV2 RELAY ON	GV2 Relay ON	
e469	GV3 RELAY ON	GV3 Relay ON	
e470	USER RELAY 1 ON	AUX1 Relay ON	
e471	USER RELAY 2 ON	AUX2 Relay ON	
e472	USER RELAY 3 ON	AUX3 Relay ON	
e473	PILOT RELAY OFF	PILOT Relay OFF	
e474	IGNITION RELAY OFF	IGNITION Relay OFF	



Error Code	Displayed	Reason for error	Possible remedy
e475	OIL RELAY OFF	OIL Relay OFF	
e476	GV1 RELAY OFF	GV1 Relay OFF	
e477	GV2 RELAY OFF	GV2 Relay OFF	
e478	GV3 RELAY OFF	GV3 Relay OFF	
e479	USER RELAY 1 OFF	AUX1 Relay OFF	
e480	USER RELAY 2 OFF	AUX2 Relay OFF	
e481	USER RELAY 3 OFF	AUX3 Relay OFF	
e482	FSG BOARD COMMS	FSG Board Comms	
e483	FSG BOARD INCORRECT	FSG Board Incorrect	
e484	FSG SELF-CHECK1	FSG Board CPU tests not completing on time	Reseat / Replace FSG Board
e485	FSG SELF-CHECK2	FSG Board CPU tests not completing on time	Reseat / Replace FSG Board
e486	FSG SELF-CHECK3	FSG Board CPU detected a specific error	See INFO screen to get FSG specific error code
e487	FSG ROM CRC	FSG CPU fails CRC ROM check	Bad programming
e488	FSG 120 OHM RESISTOR	Too many Fault Region hits	Probably a bad external resistor (not 120 Ohm)
e489	UV SELF CHECK FAIL	No break in Flame Pulses for more than 15 seconds	
e490	FALSE FLAME	Flame detected for more than 60 seconds in Standby	
e491	FLAME FAIL OIL FOG	Flame Failure from Oil Fog algorithm	
e492	FLAME FAIL	Normal Flame Failure	
e493	FORCED i01	Forced Lockout on DI 1	
e494	FORCED i02	Forced Lockout on DI 2	
e495	FORCED i03	Forced Lockout on DI 3	
e496	FORCED i04	Forced Lockout on DI 4	
e497	FORCED i05	Forced Lockout on DI 5	
e498	FORCED i06	Forced Lockout on DI 6	
e499	FORCED i07	Forced Lockout on DI 7	
e500	FORCED i08	Forced Lockout on DI 8	
e501	FORCED i09	Forced Lockout on DI 9	
e502	FORCED i10	Forced Lockout on DI 10	
e503	FORCED i11	Forced Lockout on DI 11	
e504	FORCED i12	Forced Lockout on DI 12	
e505	FORCED i13	Forced Lockout on DI 13	
e506	FORCED i14	Forced Lockout on DI 14	
e507	FORCED i15	Forced Lockout on DI 15	
e508	FORCED i16	Forced Lockout on DI 16	
e509	INVALID SENSOR DATA	Bounds checking error data structure 1	
e510	INVALID SERVO DATA	Bounds checking error data structure 2	
e511	INVALID DIG IP DATA	Bounds checking error data structure 3	
e512	INVALID PCODE DATA	Bounds checking error data structure 4	
e513	INVALID P0 DATA	Bounds checking error data structure 5	
e514	INVALID PROF 1 DATA	Bounds checking error data structure 6	
e515	INVALID PROF 2 DATA	Bounds checking error data structure 7	
e516	INVALID PROF 3 DATA	Bounds checking error data structure 8	
e517	INVALID PROF 4 DATA	Bounds checking error data structure 9	
e518	INVALID PROFILE DATA	Bounds checking error data structure 10	
e519	INVALID KEYPAD DATA	Bounds checking error data structure 11	
e520	INVALID KEY ST DATA	Bounds checking error data structure 12	
e521	INVALID TH SHK DATA	Bounds checking error data structure 13	
e522	INVALID FAULT DATA	Bounds checking error data structure 14	
e523	INVALID SETBACK DATA	Bounds checking error data structure 15	
e524	INVALID COMM DATA	Bounds checking error data structure 16	
e525	INVALID SEQ DATA	Bounds checking error data structure 17	
e526	INVALID O2 DATA	Bounds checking error data structure 18	
e527	INVALID ADJ O2 DATA	Bounds checking error data structure 19	
e528	INVALID ANALOG DATA	Bounds checking error data structure 20	
e529	INVALID VFD DATA	Bounds checking error data structure 21	
e530	INVALID VPROF 1 DATA	Bounds checking error data structure 22	
e531	INVALID VPROF 2 DATA	Bounds checking error data structure 23	
e532	INVALID VPROF 3 DATA	Bounds checking error data structure 24	
e533	INVALID VPROF 4 DATA	Bounds checking error data structure 25	
e534	INVALID BURNER DATA	Bounds checking error data structure 26	
e535	INVALID FSG DATA	Bounds checking error data structure 27	
e536	INVALID FSG DI DATA	Bounds checking error data structure 28	
e537	INVALID V-PROV DATA	Bounds checking error data structure 29	
e538	INVALID USER OP DATA	Bounds checking error data structure 30	
e539	NXF4000 FAULT	Bounds checking error data structure 31 (RESERVED)	
e540	NXF4000 FAULT	Bounds checking error data structure 32 (RESERVED)	



Error Code	Displayed	Reason for error	Possible remedy
e541	NXF4000 FAULT	Bounds checking error data structure 33 (RESERVED)	
e542	NXF4000 FAULT	Bounds checking error data structure 34 (RESERVED)	
e543	NXF4000 FAULT	Bounds checking error data structure 35 (RESERVED)	
e544	NXF4000 FAULT	Bounds checking error data structure 36 (RESERVED)	
e545	NXF4000 FAULT	Bounds checking error data structure 37 (RESERVED)	
e546	NXF4000 FAULT	Bounds checking error data structure 38 (RESERVED)	
e547	NXF4000 FAULT	Bounds checking error data structure 39 (RESERVED)	
e548	NXF4000 FAULT	Bounds checking error data structure 40 (RESERVED)	
e549	NXF4000 FAULT	Bounds checking error data structure 41 (RESERVED)	
e550	NXF4000 FAULT	Bounds checking error data structure 42 (RESERVED)	
e551	NXF4000 FAULT	Bounds checking error data structure 43 (RESERVED)	
e552	NXF4000 FAULT	Bounds checking error data structure 44 (RESERVED)	
e553	NXF4000 FAULT	Bounds checking error data structure 45 (RESERVED)	
e554	NXF4000 FAULT	Bounds checking error data structure 46 (RESERVED)	
e555	NXF4000 FAULT	Bounds checking error data structure 47 (RESERVED)	
e556	NXF4000 FAULT	Bounds checking error data structure 48 (RESERVED)	
e557	NXF4000 FAULT	Bounds checking error data structure 49 (RESERVED)	
e558	VALVE PROVING TEST 2	Failed Valve proving test at conclusion of test time 2	
e559	VALVE PROVING TEST 4	Failed Valve proving test at conclusion of test time 4	
e560	AIRFLOW ON	Airflow is on when it should be off	
e561	AIRFLOW OFF	Airflow is off when it should be on	
e562	OBSOLETE SEQ DATA	Sequencing data was copied from an older revision control	
e563	RUN CHECK TIMEOUT	User left unit in CHECK mode over 2 hours	
e564	SERVO 1 NOT CW	Master servo violates commissioning rules	<p>1. Servo direction should be double checked. It should not be changed once commissioned for any profile.</p> <p>2. Servo name and number should be checked to verify it is supposed to be the master. Changing names could cause the master servo to be changed to one that has not been verified during commissioning.</p> <p>3. If above fixes don't work, proceed to re-commission the unit to force all the values to be incrementing on the master servo.</p>
e565	SERVO 2 NOT CW	Master servo violates commissioning rules	
e566	SERVO 3 NOT CW	Master servo violates commissioning rules	
e567	SERVO 4 NOT CW	Master servo violates commissioning rules	
e568	SERVO 5 NOT CW	Master servo violates commissioning rules	
e569	SERVO 6 NOT CW	Master servo violates commissioning rules	
e570	SERVO 7 NOT CW	Master servo violates commissioning rules	
e571	SERVO 8 NOT CW	Master servo violates commissioning rules	
e572	SERVO 9 NOT CW	Master servo violates commissioning rules	
e573	SERVO 10 NOT CW	Master servo violates commissioning rules	
e574	SERVO 1 NOT CCW	Master servo violates commissioning rules	
e575	SERVO 2 NOT CCW	Master servo violates commissioning rules	
e576	SERVO 3 NOT CCW	Master servo violates commissioning rules	
e577	SERVO 4 NOT CCW	Master servo violates commissioning rules	
e578	SERVO 5 NOT CCW	Master servo violates commissioning rules	
e579	SERVO 6 NOT CCW	Master servo violates commissioning rules	
e580	SERVO 7 NOT CCW	Master servo violates commissioning rules	
e581	SERVO 8 NOT CCW	Master servo violates commissioning rules	
e582	SERVO 9 NOT CCW	Master servo violates commissioning rules	
e583	SERVO 10 NOT CCW	Master servo violates commissioning rules	



O2 Probe field calibration instruction

It's important to calibrate the O2 Probe periodically in order to achieve accurate oxygen measurement and maintain optimum combustion efficiency. Calibration of the probe can be accomplished by the following steps:

1. Start a burner cycle.
2. At the pre-purge phase, place the NXF4000 in CHECK mode by utilizing the keypad or by utilizing a digital input assigned for PURGE HOLD. When in check mode, the NXF4000 will stay in the pre-purge state indefinitely.
3. Keep system in pre-purge for at least 5 minutes in order to purge all traces of burnt/unburnt fuel. This purge time is needed to create the free-air (20.95% oxygen concentration) condition that is expected in order for the probe to calibrate properly. Extended purge time may be required for larger systems.

Note: System with multiple boilers with common flue gas outlet should be managed properly to avoid "fouling" of the probe with stack gases generated by adjacent boiler in operation.

4. After 5 minutes (or more) purge time, go to the NXF4000 display (NXD410 or Touchscreen) and navigate to the O2 SETUP menu.
5. Initiate the O2 probe calibration by executing the CALIBRATE NOW option. Calibration time is less than 15 seconds.
6. Observe the O2 reading after calibration to make sure that the O2 readout is about (20.8% \pm 0.1%).
7. Upon successful calibration, remove the FSG from check mode to allow the system to continue normal burner sequence.

MARGINAL ALARMS

The user has the option to program in marginal high limits for each of the analog transducers, including the O2 probe. A marginal condition is expected to occur before a non-volatile lockout state, giving the operator sufficient time to resolve the condition and avoid a nuisance shutdown. In these instances where an input is creating a marginal control, the control will continue to operate normally but will energize the alarm relay as an indication of the condition and display a message explaining the condition. The first line of the HOME screen will be used to post the message.

Marginal Condition	Description
SENSOR 1 MARGINAL	Sensor 1 has exceeded its programmed high marginal limit.
SENSOR 2 MARGINAL	Sensor 2 has exceeded its programmed high marginal limit.
SENSOR 3 MARGINAL	Sensor 3 has exceeded its programmed high marginal limit.
SENSOR 4 MARGINAL	Sensor 4 has exceeded its programmed high marginal limit.
SENSOR 5 MARGINAL	Sensor 5 has exceeded its programmed high marginal limit.
O2 ERROR DETECTED	The O2 probe is reporting an error condition. The control will stop trimming to the O2 level and revert to commissioned values.

FAULT HISTORY

The FAULT HISTORY submenu allows the user to examine the last 10 lockouts experienced by the NXF4000 control. When a lockout occurs, the NXF4000 automatically displays the FAULT HISTORY submenu. Along with the lockout cause the FAULT HISTORY displays the total lockouts encountered, the actual time and date of the lockout, when in the cycle the fault occurred and at what profile position. The UP/DOWN keys are used to scroll forward and backward through the fault history sub-menu. The FAULT HISTORY sub-menu is exited by using the HOME key.





NOTICE

When Fireeye products are combined with equipment manufactured by others and/or integrated into systems designed or manufactured by others, the Fireeye warranty, as stated in its General Terms and Conditions of Sale, pertains only to the Fireeye products and not to any other equipment or to the combined system or its overall performance.

WARRANTIES

FIREYE guarantees for *one year from the date of installation or 18 months from date of manufacture* of its products to replace, or, at its option, to repair any product or part thereof (except lamps, electronic tubes and photocells) which is found defective in material or workmanship or which otherwise fails to conform to the description of the product on the face of its sales order. **THE FOREGOING IS IN LIEU OF ALL OTHER WARRANTIES AND FIREYE MAKES NO WARRANTY OF MERCHANTABILITY OR ANY OTHER WARRANTY, EXPRESS OR IMPLIED.** Except as specifically stated in these general terms and conditions of sale, remedies with respect to any product or part number manufactured or sold by Fireeye shall be limited exclusively to the right to replacement or repair as above provided. In no event shall Fireeye be liable for consequential or special damages of any nature that may arise in connection with such product or part.



FIREYE
3 Manchester Road
Derry, New Hampshire 03038 USA
www.fireeye.com

NXF-4001
October 15, 2019
Supersedes JULY 18, 2019