

LST400

Ultrasonic Level / Open Channel Flow Transmitter



Introduction

This operating instruction manual provides the following information:

- Quick start guide for distance, level and flow - see page 3
- Guidelines on changing parameters - see page 6
- Installation instructions - see page 7

Table Of Contents

| | | |
|------|---|----|
| 1.0 | Introduction..... | 3 |
| 2.0 | Quick Start..... | 3 |
| 2.1 | Quick Start for Distance..... | 3 |
| 2.2 | Quick Start for Level..... | 4 |
| 2.3 | Quick Start for Flow..... | 5 |
| 3.0 | Changing Parameters..... | 6 |
| 4.0 | Installation..... | 7 |
| 4.1 | Key Description..... | 8 |
| 4.2 | Security Code..... | 8 |
| 5.0 | Configuration Distance / Level..... | 9 |
| 5.1 | Distance / Level Mode..... | 10 |
| 6.0 | Configuration Flow..... | 14 |
| 6.1 | Flow Mode..... | 15 |
| 7.0 | Working with the Key Pad in Run Mode..... | 19 |
| 7.1 | Run Mode Screen in Distance / Level Mode..... | 20 |
| 7.2 | The Relay State Screen..... | 21 |
| 7.3 | Graphic Echo Screen..... | 21 |
| 7.4 | mA Graph Screen..... | 22 |
| 8.0 | Examples..... | 22 |
| 8.1 | Distance Measurement..... | 22 |
| 8.2 | Level Measurement..... | 23 |
| 8.3 | Level Measurement and Engineering Units..... | 23 |
| 8.4 | Level Measurement Using the Lineariser Function..... | 24 |
| 8.5 | Level Measurement Using the Lineariser Function with a Non-Linear Vessel..... | 25 |
| 8.6 | Venturi Flame..... | 26 |
| 8.7 | V-Notch..... | 26 |
| 8.8 | Working with the Simulator..... | 27 |
| 8.9 | FIFO (First In First Out) Pump Cycling..... | 28 |
| 8.10 | Rotate Pump Cycling..... | 29 |
| 9.0 | Fault Finding..... | 30 |
| 10.0 | Terminal Connections..... | 31 |
| 11.0 | Dimensions..... | 32 |
| 12.0 | Declaration of Conformity..... | 34 |
| 13.0 | Warranty..... | 35 |
| 14.0 | Customer Support..... | 35 |
| 14.1 | ABB RMA Form..... | 36 |

1.0 Introduction

LST400 works on the non-contact principle of ultrasonics. A pulse of energy emits from the transducer at the speed of sound and is detected upon its return. The transmitter can distinguish the difference between a correct echo and other ambient noise. When the signal returns, LST400 measures the time period and then knowing the speed of sound, it can accurately calculate the distance from the material to the transducer. The LST400 can measure distance, level and open channel flow.

In distance mode the LST400 measures distance from the transducer. This means the 20mA will be the furthest point and the 4mA will be the closest point. In level mode the LST400 measures level in a tank. This means at the furthest point or when the tank is empty, the instrument will read 4mA. At the closest point the tank will be full and the instrument will read 20mA.

The Open Channel flow meter uses a level measurement from the LST400 and converts the reading into a flow measurement

A microprocessor then controls the output functions of the relays, display and the analogue output signals.

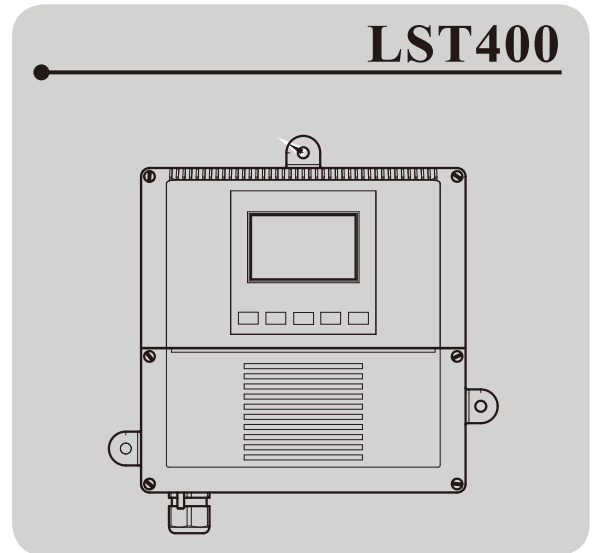

2.0 QUICK START

2.1 Quick Start For Distance

LST400 was designed with a very simple configuration program. This allows the technician to set up LST400 without the aid of a complicated source-code book. There are no references to any codes in LST400. The set up procedure is all menu-driven with the aid of questions and multiple-choice answers.

1. Connect up the power and the transducer connections as described on the LST400 board or in the LST400 manual under terminal connections on page 31.
2. Aim the transducer at a wall about 6 ft. away and check the display. It should read the following:
 - If the reading is above 6.00 ft then move the transducer closer to the wall.
 - If the reading is below 6.00 ft then move the transducer away from the wall.
 - You may now proceed and check other parameters.

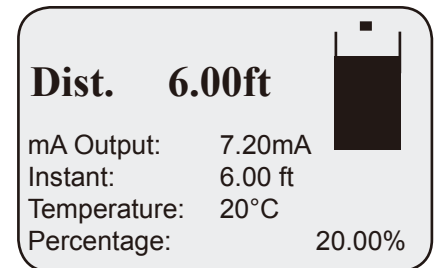

2.2 Quick Start for Level

1. Connect up the power and the transducer connections as described on the LST400 board or in the LST400 manual under terminal connections.
2. Press **SCROLL**
3. Use **▼** **▲** to get to the default security Code 5159 and then press **ENTER**
4. Press **ENTER** to scroll through the menus until the section MODE appears.
5. Press **▼** **▲** and **ENTER** to select LEVEL.
6. Press **RUN**

Aim the transducer at a wall about 6 ft away and check the display. It should read the following for a 15m Sensor transducer.

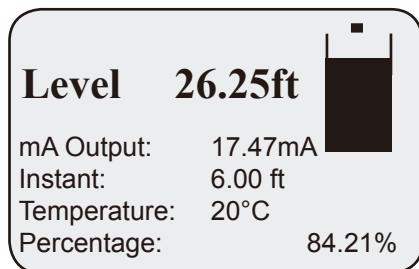

If the Head reading is below 1.64 ft then move the transducer closer to the wall.
If the Head reading is above 1.64 ft then move the transducer away from the wall.
You may now proceed and check other parameters.

2.3 Quick Start for Flow

1. Connect up the power and the transducer connections as described on the LST400 board or in the LST400 manual under terminal connections.

2. Press **SCROLL**

3. Use **▼** **▲** to get to the default security Code 5159 and then press **ENTER**

4. Press **ENTER** to scroll through the menus until the section MODE appears.

5. Press **▼** **▲** and **ENTER** to select FLOW.

6. Press **RUN**

Aim the transducer at a wall about 4.92 ft away and check the display. It should read the following for a 15m Sensor transducer.

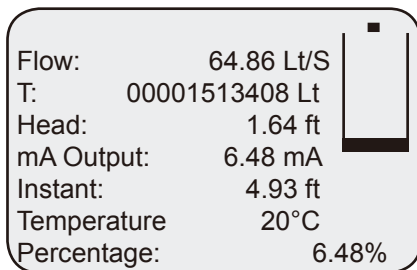

If the Head reading is below 1.64 ft then move the transducer closer to the wall.
If the Level reading is above 1.64 ft then move the transducer away from the wall.
You may now proceed and check other parameters.

- The totalizer should increase every second.

3.0 CHANGING PARAMETERS

1. Simply press **SCROLL** The SECURITY CODE prompt should be displayed.

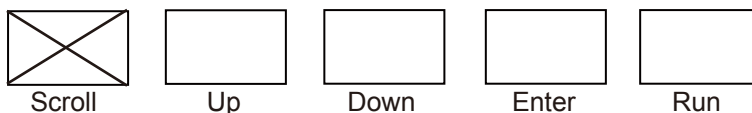
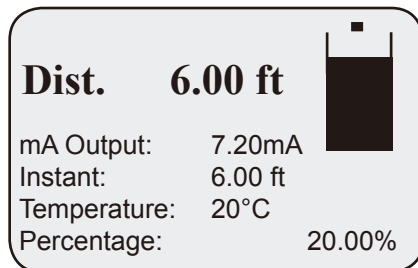

2. Enter the code 5159 by pressing the   keys.

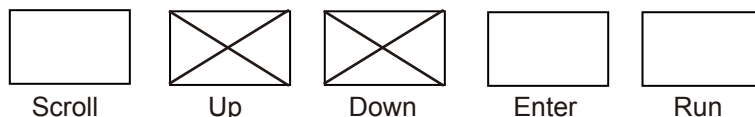
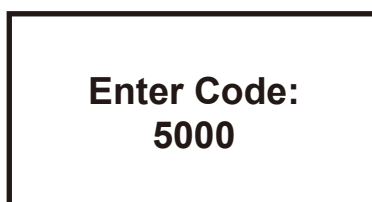

3. To confirm security code press **ENTER**

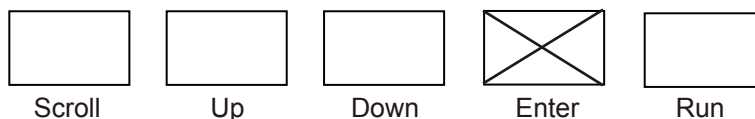
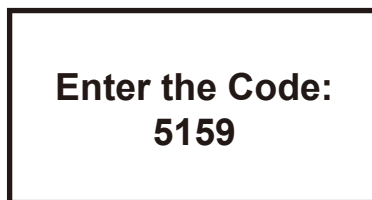

If Code has been accepted, the unit will enter the menu.

If Code has not been accepted, the screen will display:

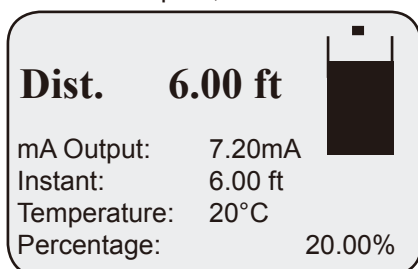

If the security code has been changed and forgotten then contact the nearest ABB agent for override code. To carry on with programming go to page 9.

4.0 INSTALLATION

The transmitter is weather proof so it can be mounted outside. Although LST400 is protected to IP65 it is recommended that it be installed inside another suitable enclosure. The LCD display should not be facing direct sunlight as this can cause the display to fail. LST400 should be fixed to a wall or chassis plate using the four holes provided.

- Do not install LST400 in areas of high vibration as this may cause failure.
- Do not install LST400 in the close vicinity of electrical cable, SCR's or variable speed drives.
- If mounting the LST400 transmitter to a wall, ensure the unit is mounted such that the wall will support greater than four times the weight of the LST400.

The installation of the transducer is the most important section of this manual and has been divided into 6 sub sections.

1. The transducer must be fitted at the normal blanking distance above the highest point of level. Check the specification for the blanking distance.
2. Always use the plastic isolation kit. This kit must be fitted to a rigid support and must not be allowed to swing. Use mild steel or a suitable plastic. Do not use stainless steel as this can cause ringing and may increase the blanking distance.
3. The transducer must be perpendicular to the material it is measuring with a clear line of sight and not above beams or filling points.

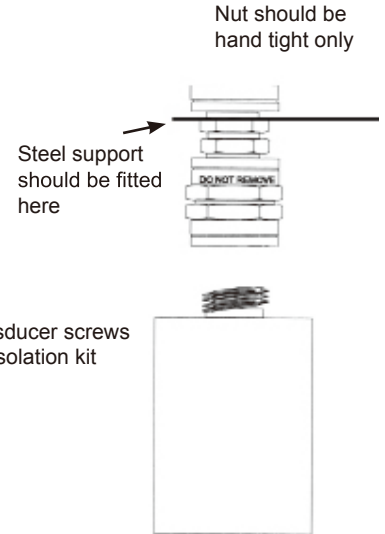

Liquid Level Measurement

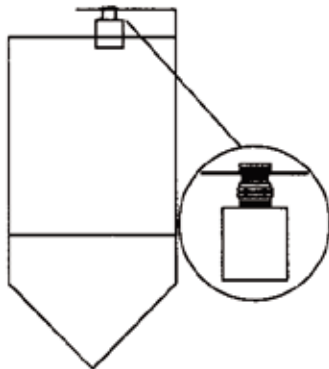

Transducer at 90 deg to surface.

Solid Level Measurement

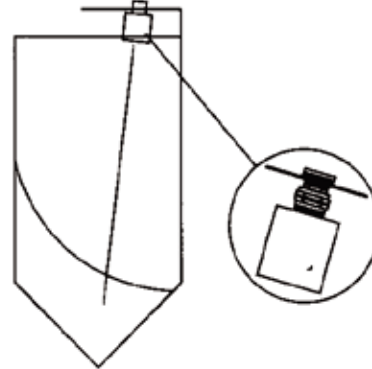

Transducer at 90 deg to surface.

4. If the transducer is in a coned vessel, it must be positioned over the middle of the cone. This ensures that the transducer receives the true echo and not one from the sides of the cone.

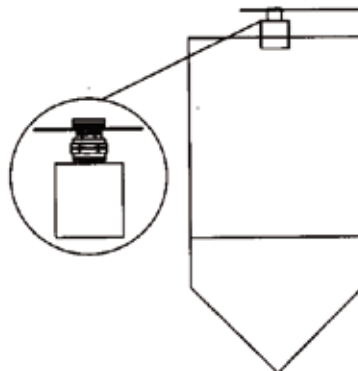

5. When a standpipe is being used it must be as wide as possible and preferably be made of plastic. The base MUST have a 45 degree chamfer to reduce the echo size from the bottom of the standpipe. No welding should be present on the inside of the pipe as this causes false echoes. Always increase the blanking 5.91 in / 150 mm past the end of the standpipe.

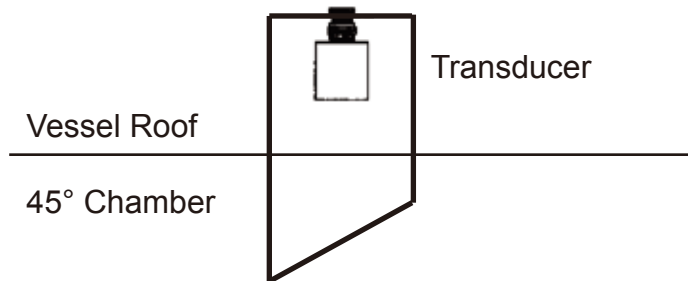

6. If any large electrical equipment is installed in the vicinity, then earthed steel conduit must be used.

4.1 Key Description

LST400 is “user friendly” having only 5 keys and a menu driven display. The keys are listed below with their appropriate functions.

SCROLL

This is used to initially access the programming and then to run through the various menus.



This key is used to DECREASE the value in the various commands. This key also starts the simulation mode increasing in level. See page 27 for details.



This key is used to INCREASE the value in the various commands. This key also starts the simulation mode increasing in level. See page 27 for details.

ENTER

When a value has been changed it is only accepted by pressing the ENTER key. The ENTER key while in run mode scrolls through the relay status screen and onscreen KScope screen and mA output graphc. See page 19 for details.

RUN

When programming is complete, press RUN to return to the run mode.

4.2 Security Code

To advance to the programming mode, the correct security code must be entered. The factory default code is 5159. This code can be changed in the programming mode. If you forget the security code please contact your local ABB agent for the override code.

5.0 CONFIGURATION DISTANCE / LEVEL

| DISTANCE / LEVEL MODE | | |
|--------------------------|--------------------------------------|-------------|
| BASIC | OPTIONS | DEFAULTS |
| SECURITY CODE | 0-9999 | 5159 |
| MODE | DISTANCE/LEVEL/FLOW/DIFF | DISTANCE |
| UNITS | FEET/METERS | FEET |
| EMPTY DISTANCE | 1.3-49.2/3.6-98.4/3.6-196.8 FT | 32.81 FT |
| SPAN | 0.33-49.2/0.33-98.4/0.33-196.8 FT | 32.81 FT |
| BLANKING | 0.98-48.87/3.28-98.07/3.28-196.47 FT | 1.65 FT |
| RATE OF CHANGE | 0.03-65.6 FT/MIN / 0.01-20.0 M/MIN | 3.28 FT/MIN |
| APPLICATION | LIQUIDS/SOLIDS | LIQUIDS |
| FACTORY RESET | NO/YES | NO |
| TEMPERATURE COMPENSATION | OFF/ON | OFF |
| SIMULATE | NO/YES | NO |
| SET PASSWORD | NO/YES | NO |
| BACKLIGHT | OFF/ON (1-6MIN)/PERM | 2MIN |
| LOSSTIME | 30-900SEC | 300SEC |
| FAILSAFE | 3.6mA, 4.0mA, 20mA, 21mA, HOLD | HOLD |
| ENGINEERING UNITS | NONE, aaa-zzz, AAA-ZZZ, 0-9 | NONE |
| MAXIMUM VALUE | 0-99999 | 100000 |
| DECIMAL POINT | 0-3 | 2 |
| ZERO OFF SET | -0.16 FT TO 0.16 FT | 0 |
| SETUP RELAYS | NO/YES | NO |
| RELAY1 TO RELAY 5 | OFF/LO/HI | OFF |
| CHANNEL SELECT | ONE/TWO/BOTH | ONE |
| SETPOINT | SPAN | 1.65 FT |
| PUMP CYCLE | OFF/FIFO/ROTATE | OFF |
| CLEAR RELAYS | NO/YES | NO |
| SETUP LINEARIZER | NO/YES | NO |
| ACTIVATE LINEARIZER | NO/YES | NO |
| SETPOINT | 1-21 | 1 |
| HEIGHT | 0 FT-SPAN | 0 FT |
| PERCENTAGE | 0-100% | 0% |

5.1 Distance / Level Mode

SECURITY CODE

Security code to advance to programming.

DEFAULT 5159

MODE

Choose between Distance, Level, or Differential. Differential option is only available with the dual unit.

DEFAULT Distance

UNITS

Choose between Feet and Meters.

DEFAULT Feet

EMPTY DISTANCE

This is the distance from the face of the transducer to the bottom of the tank.

DEFAULT 32.8 ft for 15m Sensor

SPAN

This figure is the measuring range of the instrument i.e. distance from the bottom of the tank to the highest point being measured. Remember, the material must not approach within 1.65 feet (for the K10) of the transducer face or within the blanking distance of the transducer.

DEFAULT 32.8 ft for 15m Sensor

BLANKING

This is the area where an echo cannot be processed because the return echo would be received while the transducer is still firing.

DEFAULT 1.65 ft for 15m Sensor

RATE OF CHANGE

This is used to set up the rate of change of the level output. The rate of change governs the rate at which the instrument output change. By increasing the rate of change (13.1 ft/min) it will allow the LST400 to monitor rapid changes in level. If the level moves faster than 3.28 ft/minute in measurement increase the rate of change. If a more stable output is required decrease the rate of change (1.0 ft/min).

DEFAULT 3.28 ft/min

APPLICATION

This selection can be used to select either liquid or solid applications. The solid application will provide more power to locate the correct echo.

DEFAULT Liquids

FACTORY RESET

5.1 DISTANCE / LEVEL MODE (continued)

This prompt will reset all values entered back to factory setting except the password. Please write down all settings before using this function.

DEFAULT No

TEMPERATURE COMPENSATION

Set temperature compensation on or off.

DEFAULT Off

SIMULATE

Simulates the level, relay outputs and mA outputs with the rate of change, selected.

DEFAULT No

SET PASSWORD

This prompt will allow you to change the default factory code. Should the factory code be forgotten please contact a local ABB agent for an override password.

DEFAULT No

BACKLIGHT

Choose between switching on the backlight for 1 - 60 minutes, switch off the backlight or to switch the backlight permanently on.

DEFAULT 2 Min

LOSSTIME

This is the amount of time between last receiving a correct echo and going into the Fail-safe condition. This time period is timed in seconds. This cannot be reduced to less than 30 seconds.

DEFAULT 300 Sec

FAILSAFE

If a loss of echo condition is reached then the 4-20mA output will follow the configured settings 3.60mA, 4mA, 20mA, 21mA or Hold the reading at the last recognized echo. This is usually due to a cable being cut or the instrument not being set up correctly.

DEFAULT Hold

ENGINEERING UNITS

This prompt will allow you to display in your own engineering units and can be made up from alphanumeric characters.

DEFAULT None

MAXIMUM VALUE/DECIMAL POINT

This is the maximum value the engineering units can be displayed instead of reading meters (m) or feet (ft).

DEFAULT 10000

After the maximum value is set the number of decimal points can be adjusted.

DEFAULT 2

ZERO OFFSET

Choose between -0.16 ft to 0.16 ft for setting the offset of the instrument.

DEFAULT 0

SETUP RELAYS

Select yes to enter the relay menu and set up the relay parameters.

DEFAULT No

5.1 DISTANCE / LEVEL MODE (continued)

RELAY1

The relays can be used either for a high alarm or a low alarm. A high alarm has its reset below the set point, and a low alarm has its reset above the set point. The relays can also be set up to have pump cycling enabled.

DEFAULT Off

CHANNEL

The channel to which the relay corresponds.

DEFAULT ONE

SET POINT

This is the value where the relay will set.

DEFAULT 1.65 ft

RESET POINT

This is the value where the relay will reset.

DEFAULT 1.65 ft

PUMP CYCLE

Select the type of pump control that is required. The LST400 has two pump cycling routines which can be used to efficiently distribute the run cycles between various pumps that serve a common purpose. The ROTATE pump routine will use the relay set points configured for the pumps that require cycling, and rotate these set points among the pumps with the COMPLETION of each cycle. NOTE: The COMPLETION of a cycle is reached once all pumps have switched OFF.

The FIFO (First In First Out) routine will use the relay set points configured for the pumps that require cycling, and rotate these set points among the pumps for subsequent cycles.

NOTE: The FIFO routine ensures that the lead pump will always switch off first.

HINT: It is advisable to configure the reset points for the pumps that require cycling to the same level.

DEFAULT Off

CLEAR RELAYS

Clears the number of cycles as well as the run hours recorded for the particular relay specified.

DEFAULT No

RELAY2

As above.

DEFAULT Off

RELAY3

As above.

DEFAULT Off

RELAY4

As Above.

DEFAULT OFF

RELAY 5

As Above.

DEFAULT OFF

5.1 DISTANCE / LEVEL MODE (continued)

SETUP LINEARISER

This prompt will allow you to input a curve to linearise the vessel. The span is divided by 21 and you can input the new height for each point as well as the corresponding percentage fill at that point. LST400 prompts you at each point.

DEFAULT No

ACTIVATE LINEARISER

This function activates the lineariser.

DEFAULT No

SET POINT

This is the number at which point the user is inputting a linearized point.

HEIGHT/PERCENTAGE

Height is the distance from the bottom of the tank to a corresponding point where a suitable percentage can be determined.

DEFAULT 0.00 ft

Enter the percentage volume of vessel at a corresponding height.

DEFAULT 0.00 %

| Set point 1 | |
|--------------|----------|
| Height | 0.0 m |
| Percentage | 0.00% |
| Set point 2 | |
| Height | 1.64 ft |
| Percentage | 5.00% |
| Set point 3 | |
| Height | 3.28 ft |
| Percentage | 10.00% |
| Set point 4 | |
| Height | 4.92 ft |
| Percentage | 15.00% |
| Set point 5 | |
| Height | 6.56 ft |
| Percentage | 20.00% |
| Set point 6 | |
| Height | 8.20 ft |
| Percentage | 25.00% |
| Set point 7 | |
| Height | 9.84 ft |
| Percentage | 30.00% |
| Set point 8 | |
| Height | 11.48 ft |
| Percentage | 35.00% |
| Set point 9 | |
| Height | 13.12 ft |
| Percentage | 40.00% |
| Set point 10 | |
| Height | 14.76% |
| Percentage | 45.00% |
| Set point 11 | |
| Height | 16.41 ft |
| Percentage | 50.00% |

| Set point 12 | |
|--------------|----------|
| Height | 18.05 ft |
| Percentage | 55.00% |
| Set point 13 | |
| Height | 19.69 ft |
| Percentage | 60.00% |
| Set point 14 | |
| Height | 21.33 ft |
| Percentage | 65.00% |
| Set point 15 | |
| Height | 22.97 ft |
| Percentage | 70.00% |
| Set point 16 | |
| Height | 24.61 ft |
| Percentage | 75.00% |
| Set point 17 | |
| Height | 26.25 ft |
| Percentage | 80.00% |
| Set point 18 | |
| Height | 27.89 ft |
| Percentage | 85.00% |
| Set point 19 | |
| Height | 29.53 ft |
| Percentage | 90.00% |
| Set point 20 | |
| Height | 31.17 ft |
| Percentage | 95.00% |
| Set point 21 | |
| Height | 32.81 ft |
| Percentage | 100.00% |

6.0 CONFIGURATION FLOW

| FLOW MODE | | |
|--------------------------|-----------------------------------|-------------|
| BASIC | OPTIONS | DEFAULTS |
| SECURITY CODE | 0-9999 | 5159 |
| MODE | DISTANCE/LEVEL/FLOW | DISTANCE |
| UNITS | FEET/METER | FEET |
| EMPTY DISTANCE | 1.31-49.2 ft / 0.4-15.0 m | 6.56 FT |
| SPAN | 0.33-48.21 ft / 0.1-14.7 m | 4.92 FT |
| BLANKING | 0.98-48.87 ft. / 0.3-14.9 m | 1.64 FT |
| RATE OF CHANGE | 0.03-65.6 FT/MIN/ 0.01-20.0 M/MIN | 1.64 FT/MIN |
| APPLICATION | LIQUIDS/SOLIDS | LIQUIDS |
| FACTORY RESET | NO/YES | NO |
| TEMPERATURE COMPENSATION | ON/OFF | OFF |
| SIMULATE | NO/YES | NO |
| SET PASSWORD | NO/YES | NO |
| BACKLIGHT | OFF/ON (1-60MIN) / PERM | 2 MIN |
| LOSSTIME | 30-900SEC | 300SEC |
| FAILSAFE | 3.6mA, 4.0mA, 20mA, 21mA, HOLD | HOLD |
| FLOW UNITS | SEE LIST | LT/SEC |
| MAXIMUM VALUE | 1-99999 | 1000 |
| ZERO OFF SET | -0.16 ft TO 0.16 ft | 0 ft |
| TOTALIZER COUNT | 1-1000000 | 1 |
| TOTALIZER UNITS | A-Z, a-z, 0-9 | Lt |
| TOTALIZER RESET | NO/YES | NO |
| FLOW CURVE | SEE LIST ON PAGE 17 | V-NOTCH |
| SETUP RELAYS | NO/YES | NO |
| RELAY1 TO RELAY 5 | OFF/LO/HI/COUNTER | OFF |
| SETUP LINEARISER | NO/YES | NO |
| ACTIVATE LINEARISER | NO/YES | YES |
| SETPOINT | 1-21 | 1 |
| HEIGHT | 0 ft - SPAN | 0 FT |
| PERCENTAGE | 0-100% | 0% |

6.1 Flow Mode

SECURITY CODE

Security code to advance to programming.

DEFAULT 5159

MODE

Choose Flow.

DEFAULT Distance

UNITS

Choose between Feet and Meters.

DEFAULT Meters

EMPTY DISTANCE

This is the distance from the face of the transducer to the bottom of the flume.

DEFAULT 6 ft

SPAN

This figure is measuring the range of the instrument i.e. distance from the bottom of the flume to the highest point being measured. Remember, the material must not approach within 1.65 feet of the transducer face or within the blanking distance of the transducer.

DEFAULT 4.92 ft

BLANKING

This is the area where an echo cannot be processed because the return echo would be received while the transducer is still firing.

DEFAULT 1.65 ft

RATE OF CHANGE

This is used to set up the rate of change of the level output. The rate of change governs the rate at which the instrument outputs changes. By increasing the rate of change (13 ft/min) it will allow the LST400 to monitor rapid changes in flow. If the level moves faster than 1.65 ft/min then increase the rate of change. If a more stable output is required decrease the rate of change (1.0 ft/min).

DEFAULT 1.65 ft/min

APPLICATION

This selection can be used to select either liquid or solid applications. The solid application will provide more power to locate the correct echo..

DEFAULT Liquids

6.1 FLOW MODE (continued)

FACTORY RESET

This prompt will reset all values entered back to factory setting except the password. Please write down all settings before using this function.

DEFAULT No

TEMPERATURE COMPENSATION

Sets temperature compensation on or off.

DEFAULT Off

SIMULATE

Simulates the head, Relay output and mA output at the rate of change selected.

DEFAULT No

SET PASSWORD

This prompt will allow you to change the default factory code. Should the factory code be forgotten please contact a local ABB agent for an override password.

DEFAULT No

BACKLIGHT

Choose between switching on the backlight for 1-60 minutes, switch off the backlight or to switch the backlight permanently on.

DEFAULT 2 Min

LOSSTIME

This is the time, in seconds, between last receiving a correct echo and going into the Fail-safe condition. Minimum 30 seconds.

DEFAULT 300 Sec

FAILSAFE

If the loss of echo condition is reached then the 4-20mA output will follow the configured settings 3.6mA, 4mA, 20mA, 21mA or Hold the reading at the last recognized echo. This is usually due to a cable being cut.

DEFAULT Hold

FLOW UNITS

Units can be set via the alphanumeric display to the desired value.

DEFAULT LT/SEC

MAXIMUM VALUE

This is the maximum flow rate of the flume.

DEFAULT 1000

ZERO OFFSET

Choose between -0.16 ft to 0.16 ft for small errors on the instrument.

DEFAULT 0

TOTALIZER COUNT

Choose a value where the counter will increment for a certain unit of flow between 1-1000000 when in Flow mode.

DEFAULT 1

TOTALISER UNITS

Indication of units the totaliser is set up for.

DEFAULT Lt

6.1 FLOW MODE (continued)

TOTALISER RESET

Reset the totaliser counter when in Flow mode.

DEFAULT No

FLOW CURVE

The flow element can be selected. Select from the list below:

V-notch (5/2)

Venturi (3/2)

Parshall flume 1- 96 inch

Rectangular weir (3/2)

Own curve (21 point lineariser)

DEFAULT V-Notch

SETUP RELAYS

This prompt will allow a user to enter the menu to set up the relay parameters.

DEFAULT No

RELAY1

The relays can be used either for a high alarm, a low alarm or counter in flow mode. The difference is that a high alarm has its reset below the set point, and a low alarm has its reset above the set point. The counter will output a pulse every time a certain value is reached from the totalizer, which increments by more than a user defined value when in flow mode. The relays can also be set up to have pump cycling enabled.

DEFAULT Off

CHANNEL

The channel to which the relay corresponds.

DEFAULT On

SET POINT

This is the distance value whereby the relay will set.

DEFAULT 1.65 ft

RESET POINT

This is the distance value whereby the relay will reset.

DEFAULT 1.65 ft

PUMP CYCLE

Select the type of pump control that is required. The LST400 has two pump cycling routines which can be used to efficiently distribute the run cycles between various pumps that serve a common purpose. The ROTATE pump routine will use the relay set points configured for the pumps that require cycling, and rotate these set points among the pumps with the COMPLETION of each cycle. **NOTE:** The COMPLETION of a cycle is reached once all pumps have switched OFF. The FIFO (First In First Out) routine will use the relay set points configured for the pumps that require cycling, and rotate these set points among the pumps for subsequent cycles. **NOTE:** The FIFO routine ensures that the lead pump will always switch off first. **HINT:** It is advisable to configure the reset points for the pumps that require cycling to the same level.

DEFAULT No

COUNT VALUE

Choose a value where the relay will pulse between 1-1000000 when in Flow mode.

DEFAULT 1000

6.1 FLOW MODE (continued)

CLEAR RELAYS

Clears the number of cycles as well as the run hours recorded for particular relay specified.
DEFAULT No

RELAY2

As above.
DEFAULT Off

RELAY3

As above.
DEFAULT Off

RELAY4

As above.
DEFAULT Off

RELAYS

As above.
DEFAULT Off

SETUP LINEARIZER

This prompt will allow you to input a curve to linearize the flume. The span is divided by 21 and you can input the new height for each point as well as the corresponding percentage fill at that point. LST400 prompts you at each point.
DEFAULT No

ACTIVATE

This function activates the linearizer.
DEFAULT Yes

SETPOINT

This is the number at which point the user is inputting a linearized point.

HEIGHT/PERCENTAGE

Height is the distance of the flume from the bottom to a point where a suitable percentage volume can be determined.
DEFAULT 0.00 ft

Enter the percentage volume of flume at a corresponding distance away from the bottom of the vessel or flume.
DEFAULT 0.00%

| Set point 1 | |
|--------------|---------|
| Height | 0.0 m |
| Percentage | 0.00% |
| Set point 2 | |
| Height | 0.27 ft |
| Percentage | 1.12 % |
| Set point 3 | |
| Height | 0.49 ft |
| Percentage | 3.16 % |
| Set point 4 | |
| Height | 0.74 ft |
| Percentage | 5.80 % |
| Set point 5 | |
| Height | 0.98 ft |
| Percentage | 8.94 % |
| Set point 6 | |
| Height | 1.23 ft |
| Percentage | 12.50 % |
| Set point 7 | |
| Height | 1.48 ft |
| Percentage | 12.50 % |
| Set point 8 | |
| Height | 1.72 ft |
| Percentage | 20.71 % |
| Set point 9 | |
| Height | 1.97 ft |
| Percentage | 25.30 % |
| Set point 10 | |
| Height | 2.22 ft |
| Percentage | 30.19 % |
| Set point 11 | |
| Height | 2.46 ft |
| Percentage | 35.36 % |

| Set point 12 | |
|--------------|---------|
| Height | 2.71 ft |
| Percentage | 40.79 % |
| Set point 13 | |
| Height | 2.95 ft |
| Percentage | 46.48 % |
| Set point 14 | |
| Height | 3.20 ft |
| Percentage | 52.40 % |
| Set point 15 | |
| Height | 3.45 ft |
| Percentage | 58.57 % |
| Set point 16 | |
| Height | 3.69 ft |
| Percentage | 64.95 % |
| Set point 17 | |
| Height | 3.98 ft |
| Percentage | 71.55 % |
| Set point 18 | |
| Height | 4.18 ft |
| Percentage | 78.37 % |
| Set point 19 | |
| Height | 4.43 ft |
| Percentage | 85.38 % |
| Set point 20 | |
| Height | 4.68 ft |
| Percentage | 92.59 % |
| Set point 21 | |
| Height | 4.92 ft |
| Percentage | 100.00% |

7.0 Working with the Key Pad in Run Mode

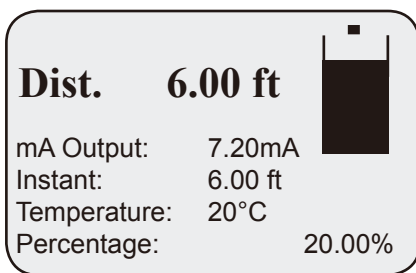

In run mode the **ENTER** key has an alternative function.

While in run mode the screen looks similar to the following:

Press **ENTER** once. The screen changes to the status screen of the relays.

| Relay | State | Hour | Cycles |
|--------|----------|------|--------|
| REL 1: | OFF | LO 0 | 2 |
| REL 2: | ON | HI 1 | 2 |
| REL 3: | ON | HI 3 | 5 |
| REL 4: | OFF | LO 0 | 0 |
| REL 5: | INACTIVE | | |

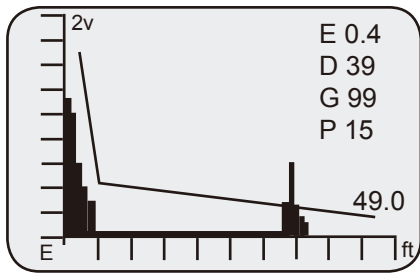

mA Output Screen

Press **ENTER** again and the screen goes to the graphic echo screen

Note: The screen reverts back to normal run mode within 2 minutes

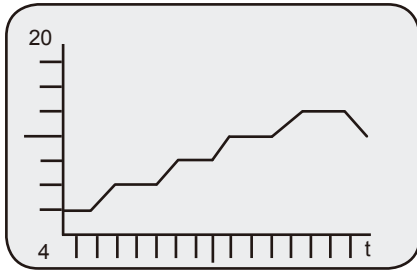

Pressing **ENTER** again while in the onscreen KScope screen will revert the screen into normal run mode.

Pressing **ENTER** again while in the graphic echo screen screen will revert the screen into normal run mode.

7.1 Run Mode Screen in Distance/Level Mode

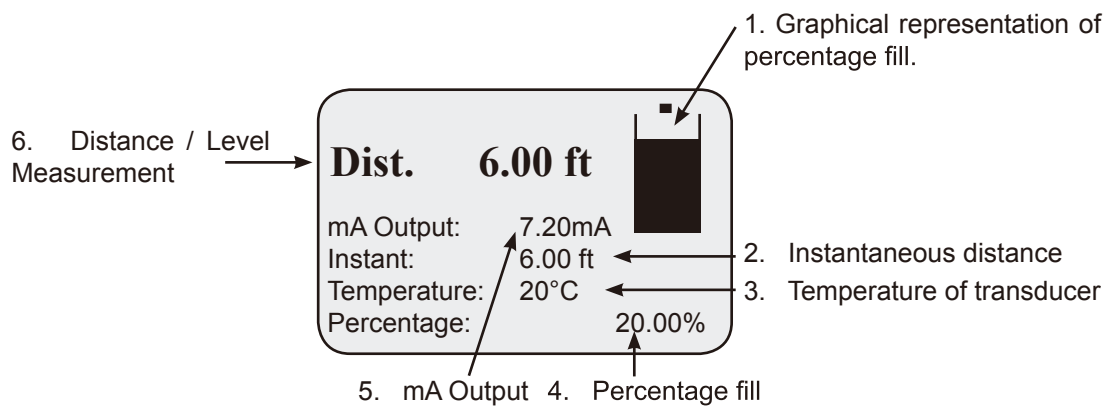

1. The graphical representation of the percentage fill of the application.
2. The instantaneous distance that the instrument is measuring at that specific time. Please note that this value can change on each pulse.
3. The temperature, which is being measured at the transducer, if temperature compensation has been enabled.
4. The value of percentage fill of the instrument.
5. The mA output of the instrument.
6. The average Distance/Level value which is calculated.

7.2 THE RELAY STATE SCREEN

Press **ENTER** while in run mode to get the RELAY STATE SCREEN.

| Relay | State | Hour | | Cycles |
|--------|----------|------|---|--------|
| REL 1: | OFF | LO | 0 | 2 |
| REL 2: | ON | HI | 1 | 2 |
| REL 3: | ON | HI | 3 | 5 |
| REL 4: | OFF | LO | 0 | 0 |
| REL 5: | INACTIVE | | | |

1. Description of column
2. Number of cycles
3. Hours relay has been on
4. Relay state
5. Relay number

1. Relay state headings.
2. The number of cycles each relay has been through.
3. The number of hours each relay has been on.
4. The state at which the relay is at ON, OFF, HI, LO and CO-Counter.
5. The relay indication number.

7.3 GRAPHIC ECHO SCREEN

Press **ENTER** twice while in run mode in order to get to the graphic echo screen

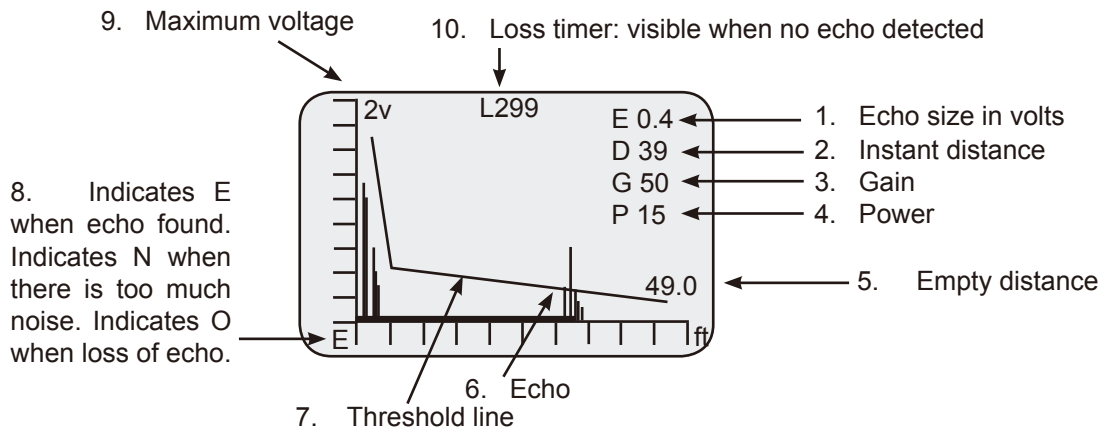

1. The maximum returned echo size in volts e.g. 0.4V
2. Displayed instant distance from transducer to substance or object being measured. e.g. 39 ft
3. The Gain needed to get the particular returned echo signal to give a particular measurement. e.g. 50%
4. The amount of power needed to obtain an echo. e.g. 15% power
5. Maximum distance or span. e.g. 49 ft
6. Graphical representation of the echo received by the transducer.
7. Threshold line whereby any echoes below this line will not be accepted.
8. Indication of good echo, noise, or loss of echo. E.g. E for good echo, N for noise or O for loss of echo.
9. The maximum voltage scale of the graphic echo screen.
10. The echo loss timer started when no signal is present.

7.4 mA GRAPH SCREEN

Displays mA output over time.

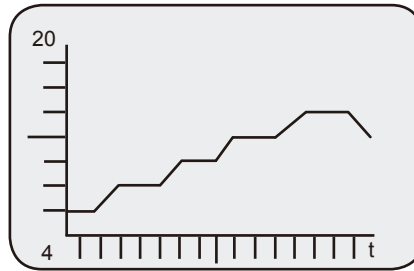

mA Output Screen

8.0 Examples

8.1 Distance Measurement

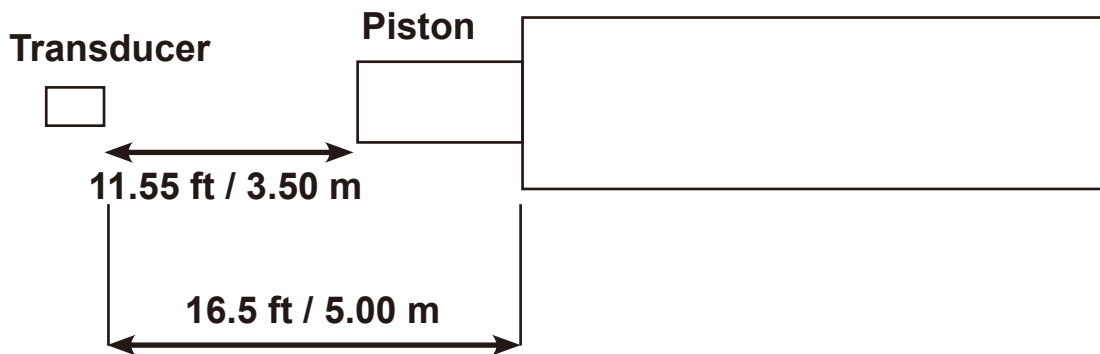

The above application deals with a moving piston:

The maximum range for the piston is 16.5 ft / 5.00 m and the closest the piston can get to the transducer is 1.63 ft / 0.50 m (Due to the blanking of the transducer).

| | |
|----------------|--------------------------|
| SECURITY CODE | 5159 |
| MODE | DISTANCE |
| EMPTY DISTANCE | 16.5 ft / 5.00 m |
| SPAN | 14.85 ft / 4.50 m |
| BLANKING | 1.63 ft / 0.50 m |
| RATE OF CHANGE | 3.28 ft/min / 1.00 m/min |

Below is what LST400 will display on the above application.

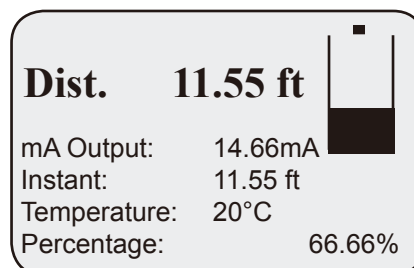

The analogue output should be approximately 14.66mA.

8.2 Level Measurement

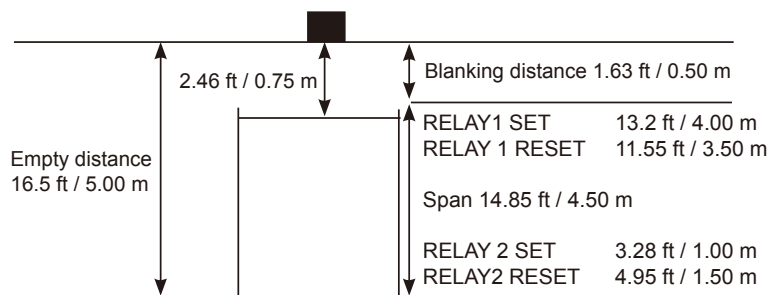

TIP: Set the relay set and reset point further apart to avoid the relays from chattering.

Below is what LST400 will display on the application above. Relay 1 will switch on (set) when the level rises above 13.2 ft / 4.00 m and reset when the level goes below 11.55 ft / 3.50 m. Relay 2 will switch on (set) when the level drops below 3.28 ft / 1.00 m and reset when the level goes above 4.95 ft / 1.50 m.

Level 13.94 ft

mA Output: 19.11mA

Instant: 2.46 ft

Temperature: 20°C

Percentage: 94.44%

| | |
|----------------|------------------------|
| SECURITY CODE | 5159 |
| MODE | LEVEL |
| EMPTY DISTANCE | 16.5 ft / 5.00 m |
| SPAN | 14.85 ft / 4.50 m |
| BLANKING | 1.63 ft / 0.50 m |
| RATE OF CHANGE | 3.28 ft/min/1.00 m/min |
| SETUP RELAYS | YES |
| RELAY 1 | HI |
| RELAY 1 SET | 13.2 ft / 4.00 m |
| RELAY 1 RESET | 11.55 ft / 3.50 m |
| RELAY 2 | LO |
| RELAY 2 SET | 3.28 ft / 1.00 m |
| RELAY 2 RESET | 4.95 ft / 1.50 m |

8.3 Level Measurement and Engineering Units

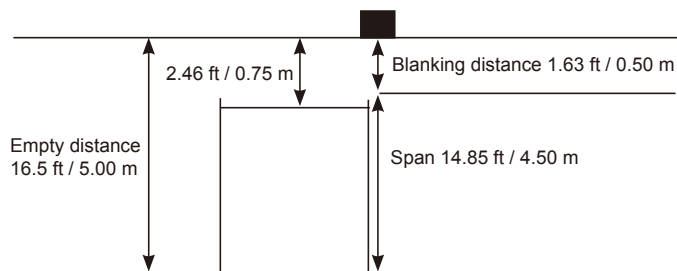

Below is what LST400 will display on the above application.
The analogue output should be approximately 19.11 mA.

ENG 37.77 LIT

mA Output: 19.11mA

Instant: 2.46 ft

Temperature: 20°C

Percentage: 94.44%

| | |
|-------------------|-----------------------|
| SECURITY CODE | 5159 |
| MODE | LEVEL |
| EMPTY DISTANCE | 16.5 ft / 5.00 m |
| SPAN | 14.85 ft / 4.50 m |
| BLANKING | 1.63 ft / 0.50 m |
| RATE OF CHANGE | 3.28 ft/min / 1 m/min |
| ENGINEERING UNITS | LIT |
| MAXIMUM VALUE | 40.00 |
| DECIMAL POINT | 40.00 |

8.4 Level Measurement Using the Lineariser Function

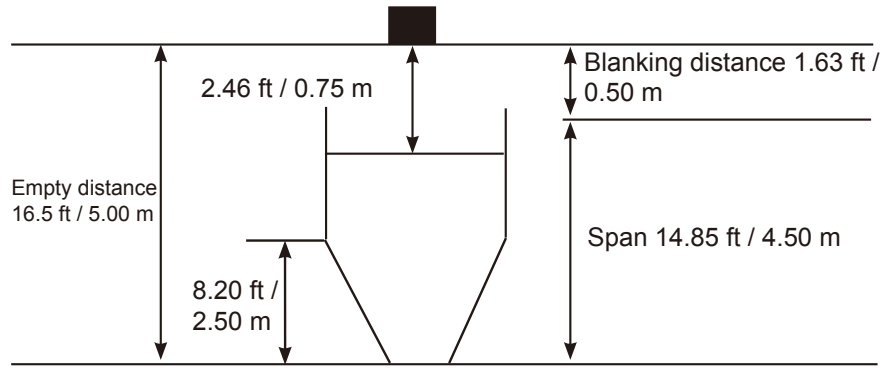

| | |
|---------------------|--------------------------|
| SECURITY CODE | 5159 |
| MODE | LEVEL |
| EMPTY DISTANCE | 16.5 ft / 5.00 m |
| SPAN | 14.85 ft / 4.50 m |
| BLANKING | 1.63 ft / 0.50 m |
| RATE OF CHANGE | 3.28 ft/min / 1.00 m/min |
| SETUP LINEARISER | YES |
| ACTIVATE LINEARISER | YES |
| 0.00 ft | 0% |
| 8.20 ft | 40% |
| 14.77 ft | 100% |

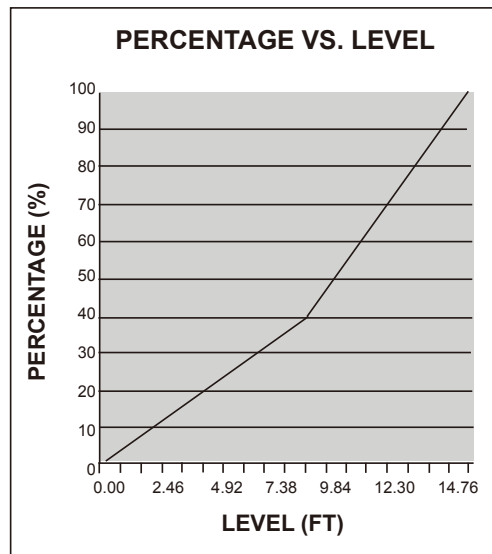

Note: Due to the curve of the graph being linear only 3 points are needed from the linearizer.

Before setting up the linearizer, check all other parameters are calculated for your application.

1. Scroll through the menus with either the **SCROLL** or **ENTER** until the menu SETUP LINEARIZER appears.
2. Use **▼** **▲** to select YES and then press **ENTER**
3. A prompt ACTIVATE LINEARIZER will appear. Use **▼** **▲** to select YES and then press **ENTER**
4. Set up each of the 21 points of the linearizer as needed by using **▼** **▲** and then pressing **ENTER**
5. When finished press **RUN**

Shown to the left is what LST400 will display on the above application. The analogue output should be approximately 18.80mA.

Level 13.94 ft

mA Output: 18.80mA

Instant: 2.46 ft

Temperature: 20°C

Percentage: 92.50%

8.5 Level Measurement Using the Lineariser Function with a Non-Linear Vessel

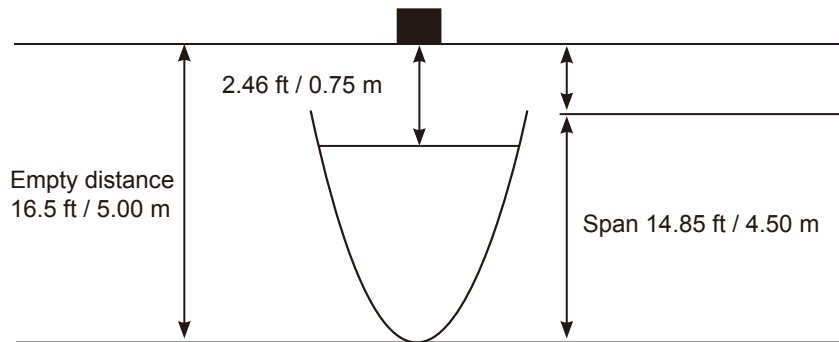

| | |
|---------------------|-------------|
| SECURITY CODE | 5159 |
| MODE | LEVEL |
| EMPTY DISTANCE | 16.5 ft |
| SPAN | 14.76 ft |
| BLANKING | 1.63 ft |
| RATE OF CHANGE | 3.28 ft/min |
| SETUP LINEARISER | YES |
| ACTIVATE LINEARISER | YES |
| 0.00 ft | 0.00% |
| 0.74 ft | 0.25% |
| 1.48 ft | 1.00% |
| 2.22 ft | 2.25% |
| 2.95 ft | 4.00% |
| 3.69 ft | 6.25% |
| 4.43 ft | 9.00% |
| 5.17 ft | 12.25% |
| 5.91 ft | 16.00% |
| 6.64 ft | 20.25% |
| 7.38 ft | 25.00% |
| 8.12 ft | 30.25% |
| 8.86 ft | 36.00% |
| 9.60 ft | 42.25% |
| 10.34 ft | 49.00% |
| 11.07 ft | 56.25% |
| 11.81 ft | 64.00% |
| 12.55 ft | 72.25% |
| 13.29 ft | 81.00% |
| 14.03 ft | 90.25% |
| 14.77 ft | 100% |

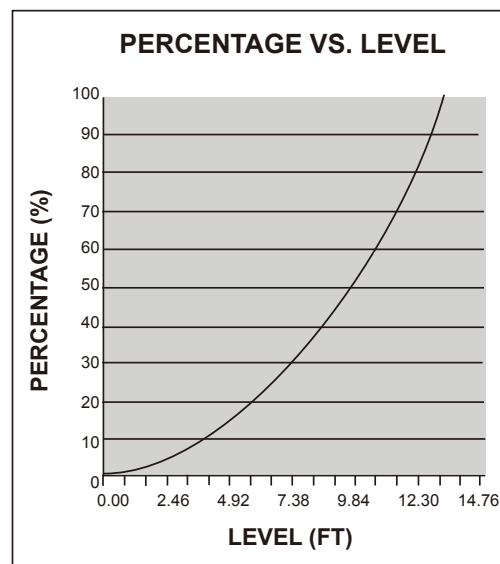

Level 13.94 ft

mA Output: 18.31mA

Instant: 2.46 ft

Temperature: 20°C

Percentage: 89.44%

Note: Due to the curve of the graph being non-linear all 21 points are needed from the lineariser. The display shown to the bottom right is what LST400 will display on the above application. The analogue output should be approximately 18.31 mA.

8.6 Venturi flume

This is an example of a Venturi Flume application. The transducer is mounted 3.94 ft / 1.20 m above the zero of the flume, this is the Empty Distance. The Span is 1.97 ft / 0.60 m and the Blanking Distance is 1.97 ft / 0.60 m. The transducer must be fitted 3 x maximum head upstream. There is an external counter connected to the relay counter. The water flow must not dam up and cause a build-up inside the flume.

Please Note! The Empty Distance is to the zero of the flume and not the bottom of the flume.

| | |
|-----------------------|--------------------------|
| SECURITY CODE | 5159 |
| MODE | FLOW |
| EMPTY DISTANCE | 3.94 ft / 1.20 m |
| SPAN | 1.97 ft / 0.60 m |
| BLANKING | 1.97 ft / 0.60 m |
| RATE OF CHANGE | 3.28 ft/min / 1.00 m/min |
| FAIL TIMER | 300 |
| FAIL SAFE | HOLD |
| FLOW UNITS | Lt/sec |
| MAXIMUM FLOW | 1435 |
| FLOW CURVE | Venturi |
| SETUP RELAYS | YES |
| RELAY 1 | Counter |
| RELAY 1 COUNTER VALUE | 1000 |
| RELAY 2 | HI |
| RELAY 2 SET | 1.64 ft / 0.50 m |
| RELAY 2 RESET | 1.61 ft / 0.49 m |
| TOTALISER RESET | NO |
| ZERO OFFSET | 0 |

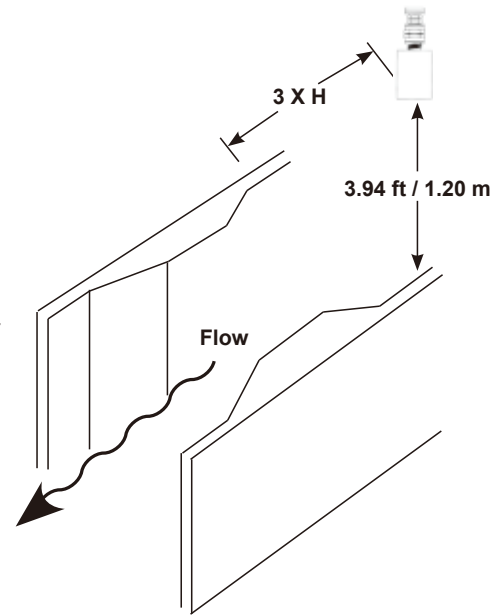

Shown to the right is what LST400 will display on the above application. The relay will drive the counter for every 1000 Lt/s and 1m³ of flow. The analogue output should be approximately 14.39 mA. Relay 2 would set at above 1.64 ft / 0.50 m and reset at below 1.61 ft / 0.49 m. TIP: Set the relay set and reset point further apart to avoid the relays from chattering.

| | | |
|--------------|----------------|---|
| Flow: | 932.17Lt/s |  |
| T: | 00001513408 Lt | |
| Head: | 1.48ft. | |
| mA Output: | 14.39 mA | |
| Instant: | 2.46 ft. | |
| Temperature: | 20°C | |
| Percentage: | 64.95% | |

8.7 V-Notch

This is an example of a V-Notch application. The transducer is mounted 6.56 ft / 2.00 m above the Notch in the V, this is the Empty Distance. The Span is 4.92 ft / 1.50 m and the Blanking Distance is 1.64 ft / 0.50 m. The transducer must be fitted 3 x maximum head upstream. There is an external counter connected to the relay counter. The water flow must not dam up and cause a build-up behind the weir.

Please Note! The Empty Distance is to the bottom of the V-Notch and not the bottom of the weir.

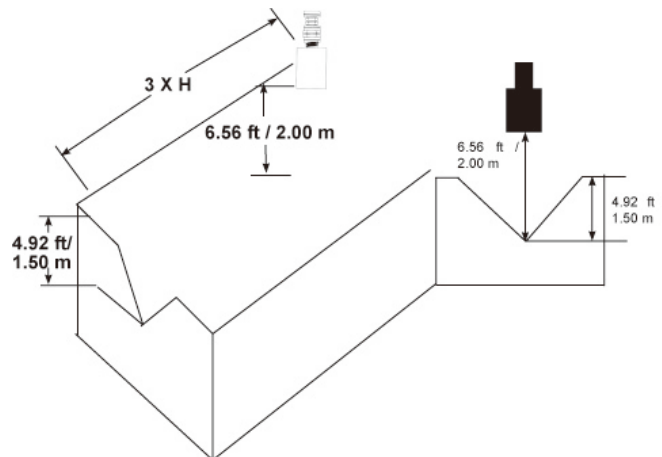

TIP: Set the relay set and reset point further apart to avoid the relays from chattering.

Below is what LST400 will display on the above application. The relay will drive the counter for every 1000 counts. The analogue output should be approximately 9.82 mA. Relay 2 will set above 4.76 ft / 1.45 m and reset below 4.43 ft / 1.35 m.

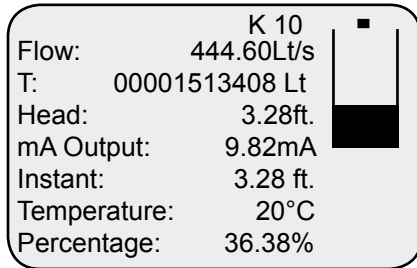

| | |
|-----------------|--------------------------|
| SECURITY CODE | 5159 |
| MODE | FLOW |
| EMPTY DISTANCE | 6.56 ft / 2.00 m |
| SPAN | 4.92 ft / 1.50 m |
| BLANKING | 1.64 ft / 0.50 m |
| RATE OF CHANGE | 3.28 ft/min / 1.00 m/min |
| FAIL TIMER | 300 |
| FAIL SAFE | HOLD |
| FLOW UNITS | Lt/sec |
| MAXIMUM FLOW | 1222 |
| FLOW CURVE | V-NOTCH |
| SETUP RELAYS | YES |
| RELAY 1 | Counter |
| RELAY 1 COUNTER | 1000 |
| RELAY 2 | HI |
| RELAY 2 SET | 4.76 ft / 1.45 m |
| RELAY 2 RESET | 4.43 ft / 1.35 m |
| TOTALISER RESET | NO |
| ZERO OFFSET | 0 |

8.8 Working with the Simulator

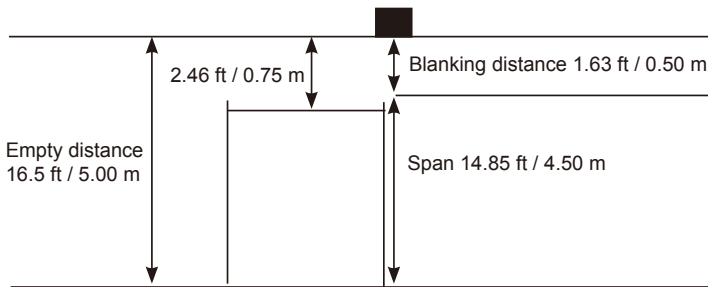

| | |
|----------------|--------------------------|
| SECURITY CODE | 5159 |
| MODE | LEVEL |
| EMPTY DISTANCE | 16.5 ft / 5.00 m |
| SPAN | 14.85 ft / 4.50 m |
| BLANKING | 1.63 ft / 0.50 m |
| RATE OF CHANGE | 3.28 ft/min / 1.00 m/min |
| SETUP RELAYS | YES |
| RELAY 1 | HI |
| RELAY 1 SET | 13.2 ft / 4.00 m |
| RELAY 1 RESET | 11.55 ft / 3.50 m |
| RELAY 2 | LO |
| RELAY 2 SET | 3.28 ft / 1.00 m |
| RELAY 2 RESET | 4.95 ft / 1.50 m |

TIP: Set the relay set and reset point further apart to avoid the relays from chattering.

In order to activate the simulator proceed with the following:

1. Scroll through the menus with either the **SCROLL** or **ENTER** until the option Simulate appears.
2. Use to select YES and then press **ENTER**
3. Press **RUN** to exit the menu.
4. Press or to start the simulator to increase or decrease the level at the rate of change.

Relay 1 will set above 13.3 ft / 4.00 m and reset below 11.55 ft / 3.50 m
Relay 2 will set below 3.28 / 1.00 m and reset above 4.95 ft / 1.50 m.

5. Press **RUN** to stop or start the simulator.

NOTE: In order for the instrument to go back to normal measurement mode, go back to the menus and select NO for the Simulate option or reset the power to the instrument.

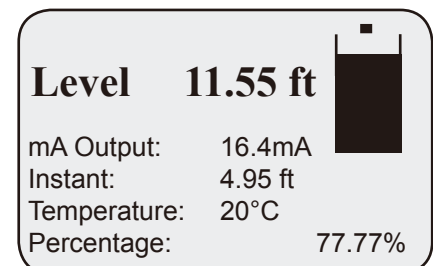

8.9 FIFO (First In First Out) Pump cycling

| | |
|----------------|--------------------------|
| SECURITY CODE | 5159 |
| MODE | LEVEL |
| EMPTY DISTANCE | 16.5 ft / 5.00 m |
| SPAN | 14.85 ft / 4.50 m |
| BLANKING | 1.63 ft / 0.50 m |
| RATE OF CHANGE | 3.28 ft/min / 1.00 m/min |
| SETUP RELAYS | YES |
| RELAY 1 | HI |
| RELAY 1 SET | 4.95 ft / 1.50 m |
| RELAY 1 RESET | 3.28 ft / 1.00 m |
| PUMP CYCLING | FIFO |
| RELAY 2 | HI |
| RELAY 2 SET | 11.55 ft / 3.50 m |
| RELAY 2 RESET | 8.20 / 2.50 m |
| PUMP CYCLING | FIFO |
| RELAY 3 | HI |
| RELAY 3 SET | 13.2 ft / 4.00 m |
| RELAY 3 RESET | 9.84 ft / 3.00 m |
| PUMP CYCLING | FIFO |

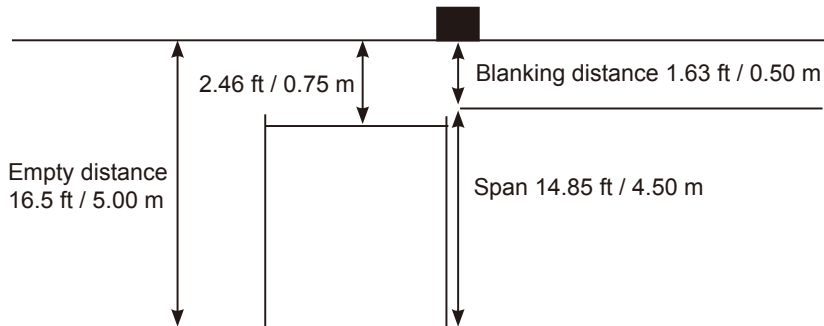

TIP: Set the relay set and reset point further apart to avoid the relays from chattering.

The following will occur in the FIFO pump cycling routine:

| Relay | Status | Time on in hrs |
|---------------------------|--------|----------------|
| Sequence 1 Level 4.27 ft | | |
| Relay 1 | OFF | 0 |
| Relay 2 | OFF | 0 |
| Relay 3 | OFF | 0 |
| Sequence 2 Level 7.22 ft | | |
| Relay 1 | ON | 1 |
| Relay 2 | OFF | 0 |
| Relay 3 | OFF | 0 |
| Sequence 3 Level 11.81 ft | | |
| Relay 1 | ON | 2 |
| Relay 2 | ON | 1 |
| Relay 3 | OFF | 0 |
| Sequence 4 Level 14.11 ft | | |
| Relay 1 | ON | 3 |
| Relay 2 | ON | 2 |
| Relay 3 | ON | 1 |
| Sequence 5 Level 9.19 ft | | |
| Relay 1 | OFF | 4 |
| Relay 2 | ON | 3 |
| Relay 3 | ON | 2 |

| Relay | Status | Time on in hrs |
|---------------------------|--------|----------------|
| Sequence 6 Level 7.22 ft | | |
| Relay 1 | OFF | 4 |
| Relay 2 | OFF | 4 |
| Relay 3 | ON | 3 |
| Sequence 7 Level 2.63 ft | | |
| Relay 1 | OFF | 4 |
| Relay 2 | OFF | 4 |
| Relay 3 | OFF | 4 |
| Sequence 8 Level 5.91 ft | | |
| Relay 1 | ON | 5 |
| Relay 2 | OFF | 4 |
| Relay 3 | OFF | 4 |
| Sequence 9 Level 2.63 ft | | |
| Relay 1 | OFF | 6 |
| Relay 2 | OFF | 4 |
| Relay 3 | OFF | 4 |
| Sequence 10 Level 5.91 ft | | |
| Relay 1 | OFF | 6 |
| Relay 2 | ON | 5 |
| Relay 3 | OFF | 4 |

8.10 Rotate Pump Cycling

| | |
|----------------|-------------------------|
| SECURITY CODE | 5159 |
| MODE | LEVEL |
| EMPTY DISTANCE | 16.5 ft / 5.00 m |
| SPAN | 14.85 ft / 4.50 m |
| BLANKING | 1.63 ft / 0.50 m |
| RATE OF CHANGE | 3.28 ft/in / 1.00 m/min |
| SETUP RELAYS | YES |
| RELAY 1 | HI |
| RELAY 1 SET | 4.95 ft / 1.50 m |
| RELAY 1 RESET | 3.28 ft / 1.00 m |
| PUMP CYCLING | ROTATE |
| RELAY 2 | HI |
| RELAY 2 SET | 11.55 ft / 3.50 m |
| RELAY 2 RESET | 8.2 ft / 2.50 m |
| PUMP CYCLING | ROTATE |
| RELAY 3 | HI |
| RELAY 3 SET | 13.2 ft / 4.00 m |
| RELAY 3 RESET | 9.84 ft / 3.00 m |
| PUMP CYCLING | ROTATE |

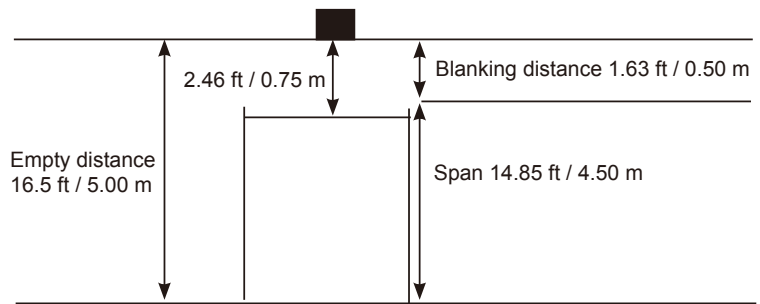

TIP: Set the relay set and reset point further apart to avoid the relays from chattering.

The following will occur in the Rotate pump cycling routine:

| Relay | Status | Time on in hrs |
|---------------------------|--------|----------------|
| Sequence 1 Level 4.27 ft | | |
| Relay 1 | OFF | 0 |
| Relay 2 | OFF | 0 |
| Relay 3 | OFF | 0 |
| Sequence 2 Level 7.22 ft | | |
| Relay 1 | ON | 1 |
| Relay 2 | OFF | 0 |
| Relay 3 | OFF | 0 |
| Sequence 3 Level 11.81 ft | | |
| Relay 1 | ON | 2 |
| Relay 2 | ON | 1 |
| Relay 3 | OFF | 0 |
| Sequence 4 Level 14.11 ft | | |
| Relay 1 | ON | 3 |
| Relay 2 | ON | 2 |
| Relay 3 | ON | 1 |
| Sequence 5 Level 9.19 ft | | |
| Relay 1 | ON | 4 |
| Relay 2 | ON | 3 |
| Relay 3 | OFF | 2 |

| Relay | Status | Time on in hrs |
|--------------------------|--------|----------------|
| Sequence 6 Level 7.22 ft | | |
| Relay 1 | ON | 5 |
| Relay 2 | OFF | 4 |
| Relay 3 | OFF | 2 |
| Sequence 7 Level 2.63 ft | | |
| Relay 1 | OFF | 6 |
| Relay 2 | OFF | 4 |
| Relay 3 | OFF | 2 |
| Sequence 8 Level 5.91 ft | | |
| Relay 1 | OFF | 6 |
| Relay 2 | ON | 5 |
| Relay 3 | OFF | 2 |
| Sequence 9 Level 2.63 ft | | |
| Relay 1 | OFF | 6 |
| Relay 2 | OFF | 6 |
| Relay 3 | OFF | 2 |
| Sequence 8 Level 5.91 ft | | |
| Relay 1 | OFF | 6 |
| Relay 2 | OFF | 6 |
| Relay 3 | ON | 3 |

9.0 FAULT FINDING

There are three categories of possible faults: the malfunction of the instrument, loss of echo, and wrong reading. The biggest problem is to identify the malfunction. If the instrument is not working satisfactorily then remove the transmitter and transducer to the workshop. Connect the power and the transducer directly, not using any extension cable. Aim the transducer to a wall about 4.95 ft / 1.5 m away, making sure that it is perpendicular to the wall. Now reset the instrument by the Factory Reset prompt. The Instrument should now read Distance 4.95 ft / 1.50 m. If it does not read the above then there is a malfunction with the instrument and it should be returned for repair. If the above works and it still does not work in the field then there are many possible problems. A list of possible problems follow.

If the above works and it still does not work in the field then there are many possible problems, which is listed below.

Loss of echo.

- Check all transducer cable connections and that the joints are soldered together.
- Check the specification of the transducers as agitated surfaces and solids do not reflect as powerful a signal as flat surfaces.
- Aim the transducer straight down if used on liquids and perpendicular if used on solids.
- Check if the transducer face is dirty.

Wrong reading, always reading close to Transducer

- Check to see if the isolation kit has been used correctly and is only hand tight.
- Do not reduce blanking distance below 1.63 ft / 0.5 m unless consultation has been made with ABB.
- Electrical noise can cause this error. Remove noise.

Wrong reading, anywhere in weir/channel

- Check to see if there is a reflection from the wall. Please Note! A piece of wire across a tank can cause a big enough echo to be accepted.
- Are the parameters correct? Reset to factory default and check that LST400 reads correctly. If the factory settings are OK then your parameters need to be changed. Re-check these parameters with a tape measure.

Wrong reading, erratic.

- Reduce Rate of Change. Not many levels move faster than 3.28 foot/minute / 1 meter/minute.
- Make sure the application is set up correctly. On liquid applications it is very important that the liquid application is selected. Solid applications are only used for objects or substances being measured, which are in a solid form.

Wrong reading, slow

- Increase Rate of Change.

10.0 Terminal connections

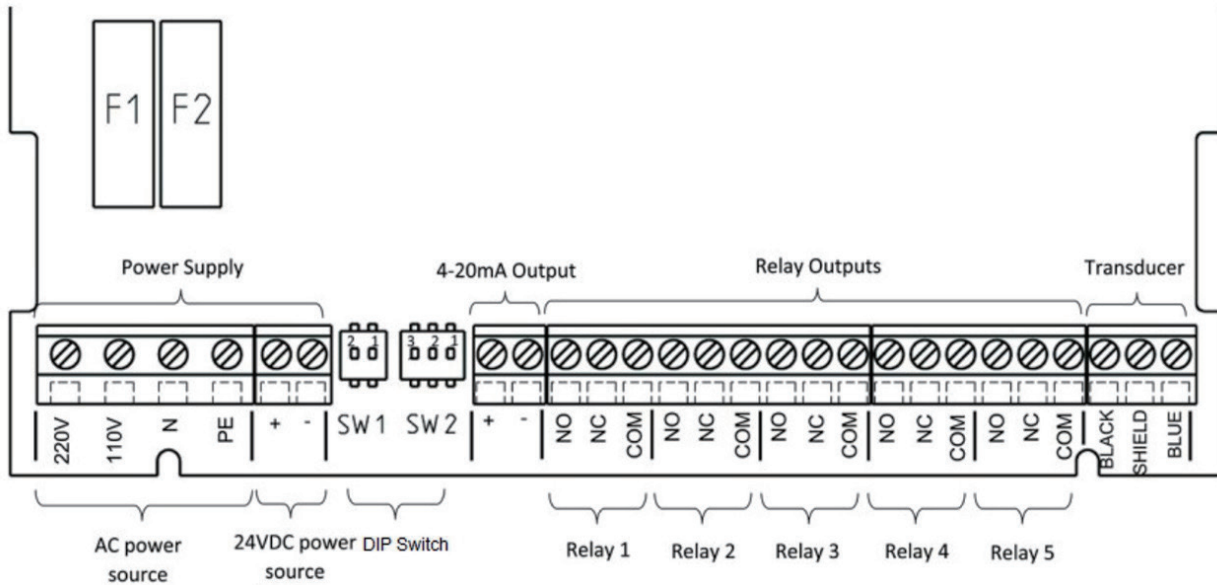

DIP Switch (SW1 & SW2)

DIP SW1

- AC Power Source (220VAC/110VAC) : SW1 CH1&2 OFF;
- DC Power Source (24VDC) : SW1 CH1&2 ON;

DIP SW2

- Active Current Output Mode(do not need external power supply): SW2 CH 1&2 ON, CH3 OFF;
- Passive Current Output Mode(need external power supply): SW2 CH 1&2 OFF, CH3 ON ;

Power supply (PWR Supply)

Note: Do not connect more than one power supplies at the same time.

LST400 can be powered by 220VAC, 110VAC or 24VDC. Follow below connections for different powers.

- 220VAC Connection
Connect '220V' Terminal with LIVE, connect 'N' Terminal with NEUTRAL and connect 'PE' Terminal with Earth.
- 110VAC Connection
Connect '110V' Terminal with LIVE, connect 'N' Terminal with NEUTRAL and connect 'PE' Terminal with Earth.
- 24VDC Connection
Connect '24VDC + / -' Terminals with 24V DC, connect 'PE' Terminal with Earth.

4-20mA (including HART Communication)

Active Mode

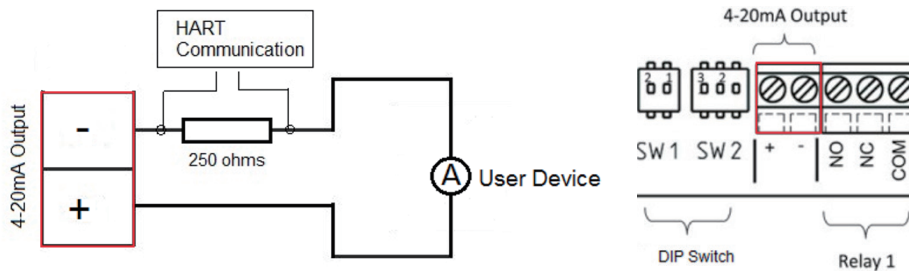

Passive Mode

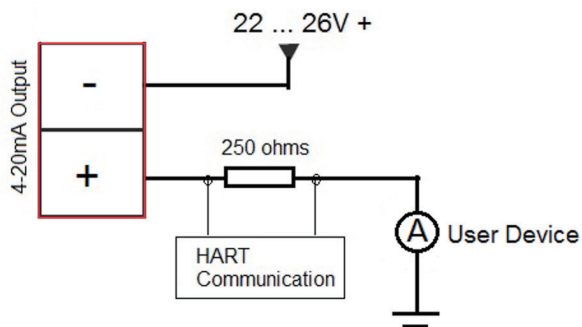

Note: If SW2 is set as Passive Mode, the polarity is opposite as shown in figure above.

Relays (Relay Output)

- Max. 5 relays can be set for LST400 (Relay 1 – 5)
- Type: 1 Form C (Changeover)
- Rating: 12A@250VAC
- Functions: pump control output, alarms, etc.

Transducer (Transducer)

- Connect 'BLACK' with the black wire, which is for temperature signal.
- Connect 'SHIELD' with shield, which is for common ground of both signal wires.
- Connect 'BLUE' with blue wire, which is for measurement signal.

Fuses (F1 & F2)

Fuses can only be replaced by a trained electrical technician if broken.

Fuse specifications:

- F1: 250VAC 50mA time lag
- F2: 250VAC 80mA time lag

11.0 DIMENSIONS

Transmitter

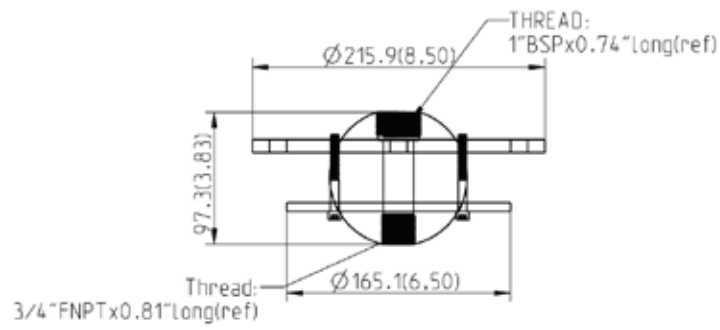

Mounting Kit

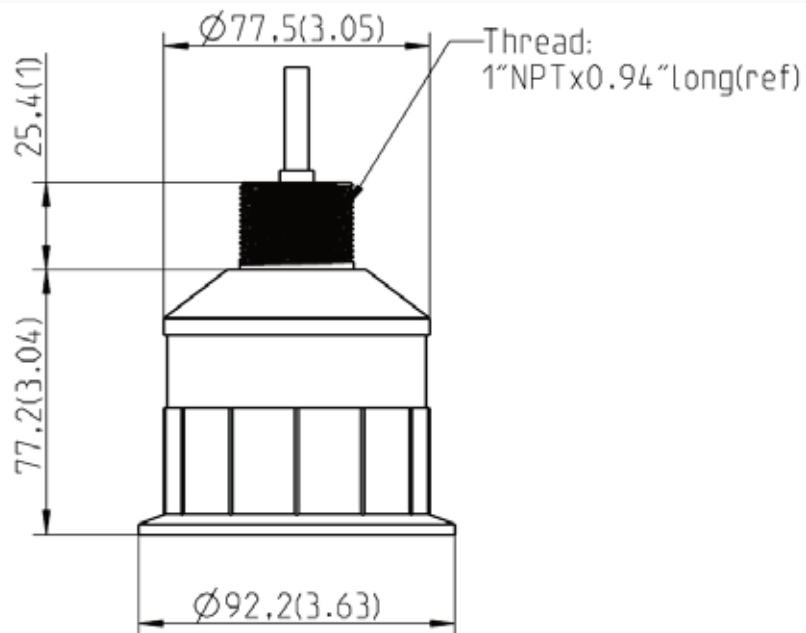

General Purpose 15m Sensor

- Maximum Measuring Length (ML) 50 ft. / 15 m
- Application: general use non-corrosive liquid

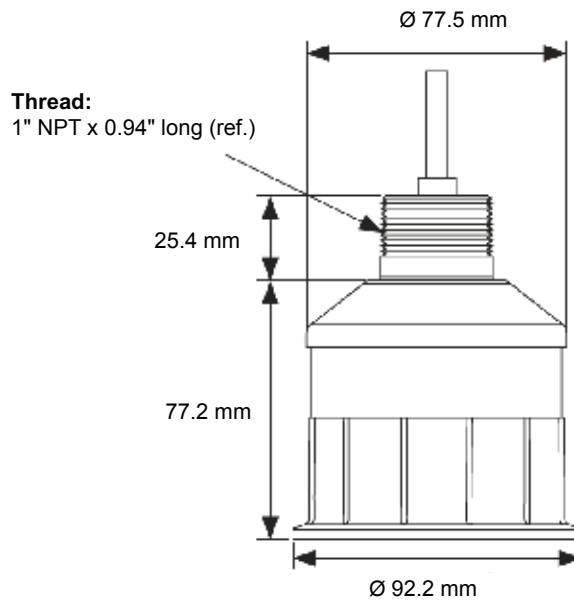

Foam Face 15m Sensor

- Maximum measuring length 50fy / 15m.
- Application: General use in solid materials.





EC-DECLARATION OF CONFORMITY

EMC Directive 2004/108/EC
& LV Directive 2006/95/EC

Manufacturer's Name:

ABB Engineering (Shanghai) Ltd.

Manufacturer's Address:

No.5, Lane 369, ChuangYe Road
KangQiao Town, PuDong New District
Shanghai, 201319, P.R. China

Declares under our sole responsibility that the product:

LST400 Ultrasonic Level Transmitter
Type Designators: LST400

to which this declaration relates is in conformity with the following standards:

| | |
|-----------------------|--|
| EN 61000-4-2 | ESD |
| EN 61000-4-3+A1 :2008 | Radiated RF Immunity |
| EN 61000-4-4 | Electrical Fast Transients/Bursts |
| EN 61000-4-5 | Voltage Surges |
| EN 61000-4-6 | Conducted RF fields |
| EN 61000-4-8 | Rated power frequency magnetic field |
| EN 61000-4-11 | Voltage Dips and Interruptions |
| EN 61010-1 :2001 | Safety Requirements for Electrical Equipment for Measurement and Laboratory use |

when installed and operated according to the supplied instructions.

Shanghai, China

Rock-Rendong li 2013-02-01

ABB Engineering (Shanghai) Ltd.

13.0 Warranty

5 YEAR WARRANTY FOR:

KM26 Magnetic Liquid Level Gauges; MagWave Dual Chamber System; LS Series Mechanical Level Switches (LS500, LS550, LS600, LS700, LS800 & LS900); EC External Chambers, STW Stilling Wells and ST95 Seal Pots.

3 YEAR WARRANTY FOR:

KCAP300 & KCAP400 capacitance switches. BETA Pressure and Temperature Switches have a limited factory guarantee, excluding wetted parts & consumables.

2 YEAR WARRANTY FOR:

AT100, AT100S and AT200 series transmitters; RS80 and RS85 liquid vibrating fork switches; RLT100 and RLT200 reed switch level transmitters; TX, TS, TQ, IX and IM thermal dispersion switches; IR10 and PP10 External Relays; MT2000, MT5000, MT5100 and MT5200 radar level transmitters; RI100 Repeat Indicators; KP paddle switches; A02, A75 & A77 RF capacitance level switches and A38 RF capacitance level transmitters; Buoyancy Level Switches (MS50, MS10, MS8D & MS8F); Magnetic Level Switches (MS30, MS40, MS41, PS35 & PS45).

1 YEAR WARRANTY FOR:

KM50 gauging device; AT500 and AT600 series transmitters; LaserMeter and SureShot series laser transmitters; LPM200 digital indicator; DPM100 digital indicators; APM100 analog indicators; KVIEW series digital indicators and controllers; SF50 and SF60 vibrating fork switches, KB Electro-Mechanical Continuous Measuring Devices, KMicro and LST ultrasonic level transmitters, transmitters & transducers, ChuteMaster Microwave Transmitter / Receiver and TiltMaster Switches.

SPECIAL WARRANTY CONSIDERATIONS:

ABB does not honor OEM warranties for items not manufactured by ABB (i.e. Palm Pilots). These claims should be handled directly with the OEM.

ABB will repair or replace, at ABB's election, defective items which are returned to ABB by the original purchaser within the period specified above from the shipment date of the item and which is found, upon examination by ABB, to its satisfaction, to contain defects in materials or workmanship which arose only under normal use and service and which were not the result of either alterations, misuse, abuse, improper or inadequate adjustments, applications or servicing of the product. ABB's warranty does not include onsite repair or services. Field service rates can be supplied on request.

If a product is believed to be defective, the original purchaser shall notify ABB and request a Returned Material Authorization before returning the material to ABB, with transportation prepaid by the purchaser. (To expedite all returns/repairs from outside of the United States, consult ABB's customer service team (service@ktekcorp.com) to determine an optimal solution for shipping method and turnaround time.) The product, with repaired or replaced parts, shall be returned to the purchaser at any point in the world with transportation prepaid by ABB for best-way transportation only. ABB is not responsible for expedited shipping charges. If the product is shipped to ABB freight collect, then it will be returned to the customer freight collect.

If inspection by ABB does not disclose any defects in material or workmanship, ABB's normal charges for repair and shipment shall apply (minimum 250.00 USD).

The materials of construction for all ABB products are clearly specified and it is the responsibility of the purchaser to determine the compatibility of the materials for the application.

THE FOREGOING WARRANTY IS ABB'S SOLE WARRANTY AND ALL OTHER WARRANTIES EXPRESSED, IMPLIED, OR STATUTORY, INCLUDING ANY IMPLIED WARRANTY OF MERCHANTABILITY OF FITNESS FOR A PARTICULAR PURPOSE, ARE EXCLUDED AND NEGATED TO THE MAXIMUM EXTENT PERMITTED BY LAW. NO PERSON OR REPRESENTATIVE IS AUTHORIZED TO EXTEND ANY OTHER WARRANTY OR CREATE FOR ABB ANY OTHER LIABILITY IN CONNECTION WITH THE SALE OF ABB'S PRODUCTS. THE REMEDIES SET FORTH IN THIS WARRANTY ARE EXCLUSIVE OF ALL OTHER REMEDIES AGAINST ABB. ABB SHALL NOT BE LIABLE FOR ANY CONSEQUENTIAL, INCIDENTAL, OR SPECIAL DAMAGES OF ANY KIND. ABB'S SOLE OBLIGATION SHALL BE TO REPAIR OR REPLACE PARTS (FOUND TO BE DEFECTIVE IN MATERIALS OR WORKMANSHIP) WHICH ARE RETURNED BY THE PURCHASER TO ABB.

14.0 Customer Support

ABB Engineering (Shanghai) Ltd.
No. 4528, Kangxin Highway
Pudong District, Shanghai
201319, P.R. China
Phone: 4008209696
Fax: +86 21 61056677
Email: instrumentsservice.abbchina@cn.abb.com

14.1 ABB RMA Form



ABB Engineering (Shanghai) Ltd.
 No. 4528, Kangxin Highway
 Pudong District, Shanghai
 201319, P.R. China
 Phone: 4008209696
 Fax: +86 21 61056677
 Email: instrumentservice.abbchina@cn.abb.com
 www.abb.com/level

***** IMPORTANT CUSTOMER NOTICE: PLEASE READ PRIOR TO RETURNING PRODUCTS TO ABB*****

Be sure to include the Return Authorization (RA) number on the shipping label or package to the attention: Customer Service. A copy of this document should also be included with the packing list. ABB wants to maintain a safe work environment for its employees. In the event, the returned product or material has been in contact with a potentially hazardous chemical, per federal regulations, the customer must provide evidence of decontamination and the related chemical composition and characteristics. In order to expedite your return, please include the applicable Material Safety Data Sheets (MSDS) and decontamination tags by affixing these documents in close proximity to the shipment label for identification purposes. (January 18, 2006)

Return Authorization Form

| | |
|----------------|--------------|
| Customer: | Date: |
| Contact Name: | Product: |
| Contact Email: | Serial No: |
| Contact Phone: | Job No: |
| Contact Fax: | Service Rep: |

Completed by Customer

Reason:

Problem Found: None

Action None

Requested:

Is expedited return shipping requested? Yes

*If yes, please provide a purchase order or your shipper's account number (ex FedEx or UPS).
 ABB pays return transport via standard ground shipments only.*

Account #:

If purchase order is issued, a copy of purchase order must be included with return authorization documentation.

Is ABB authorized to repair items determined to be non-warranty? Yes

If yes, a copy of purchase order must be included with return authorization documentation.

| | | | |
|---------------|--|-------|--|
| Customer PO#: | <input style="width: 90%;" type="text"/> | Date: | <input style="width: 90%;" type="text"/> |
|---------------|--|-------|--|

Has product been in contact with any potentially hazardous chemical? Yes

If yes, documentation product and forward MSDS to ABB. "ATTN: Customer Service"

Return Repaired Product to Address

| | |
|-------------------|--|
| Shipping Address: | Billing Address: |
| | |
| | Ship Via: <input style="width: 80%;" type="text"/> |

Contact us

ABB Engineering (Shanghai) Ltd.
No. 4528, Kangxin Highway
Pudong District, Shanghai
201319, P.R. China
Phone: 4008209696
Fax: +86 21 61056677
Email: instrumentservice.abbchina@cn.abb.com

www.abb.com/level

ABB Inc.

Process Automation

125 E. County Line Rd
Warminster PA 18974-4995, USA
Tel: +1 215 674 6000
Fax: +1 215 674 7183

ABB Limited

Process Automation

Howard Road
St. Neots
Cambridgeshire PE19 8EU
UK
Tel: +44 (0)1480 475321
Fax: +44 (0)1480 217948

www.abb.com/level

Note

We reserve the right to make technical changes or modify the contents of this document without prior notice. With regard to purchase orders, the agreed particulars shall prevail. ABB does not accept any responsibility whatsoever for potential errors or possible lack of information in this document.

We reserve all rights in this document and in the subject matter and illustrations contained therein. Any reproduction, disclosure to third parties or utilization of its contents - in whole or in parts - is forbidden without prior written consent of ABB.

Copyright© 2016 ABB
All rights reserved