

**RS85**

## Vibrating fork level switch

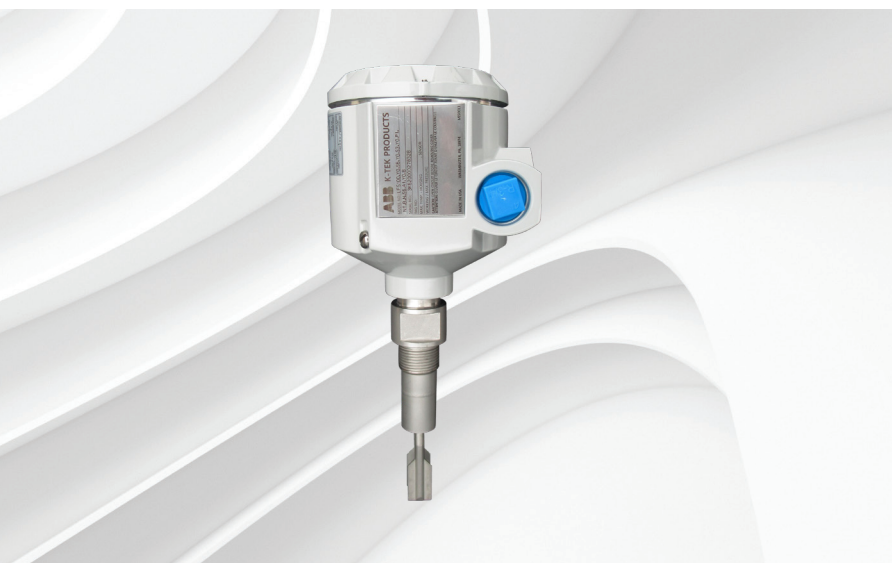

K-TEK Level products

**Measurement made easy****Introduction**

This operating instruction manual provides the following information:

- installation
- setup
- time delay
- troubleshooting

## Contents

<b>1</b>	<b>Description .....</b>	<b>3</b>
<b>2</b>	<b>Installation .....</b>	<b>5</b>
<b>3</b>	<b>Setup .....</b>	<b>10</b>
<b>4</b>	<b>Time delay .....</b>	<b>13</b>
<b>5</b>	<b>Troubleshooting .....</b>	<b>14</b>
<b>6</b>	<b>Warranty statement .....</b>	<b>15</b>
<b>7</b>	<b>ABB RMA form .....</b>	<b>16</b>

# 1 Description

## Introduction

The RS85 switch is a vibrating fork switch designed for liquid level detection. The robust sensor design and built-in temperature compensation ensure reliable response even in the presence of very extreme process conditions. The LED indicators of the RS85 modular electronics allow for simple set-up and status detection. Configuration is via pushbuttons or a provided magnet. The rugged construction allows it to withstand the rigors of just about any industrial environment.

## Theory of operation

The RS85 vibrating switch utilizes a piezoelectric driven tuning fork that exhibits a change in resonant frequency when the forks are immersed in any liquid. 'Smart' microprocessor-based electronics keep the sensor in a resonant state as it changes from dry to wet or wet to dry. The resonant frequency is continuously monitored for changes created by a wet or dry sensor and an alarm (change in LED) is provided along with a DPDT relay. An important feature of this device is that its resonant frequency is not significantly affected by coating on the fork unless the space between the forks is bridged. The RS85 ability to identify true liquid level in viscous, coating or aerated liquid is unparalleled. The self-test option continuously checks for fault conditions such as a damaged sensor and under fault conditions displays a blinking red LED visible through the glass cover. Applications include high/low liquid level detection and are unaffected by parameters such as specific gravity, dielectric constant or mounting position of the sensor.

## Specification

For detailed specifications consult the RS85 data sheet (DS/RS85-EN).

## Dimensions

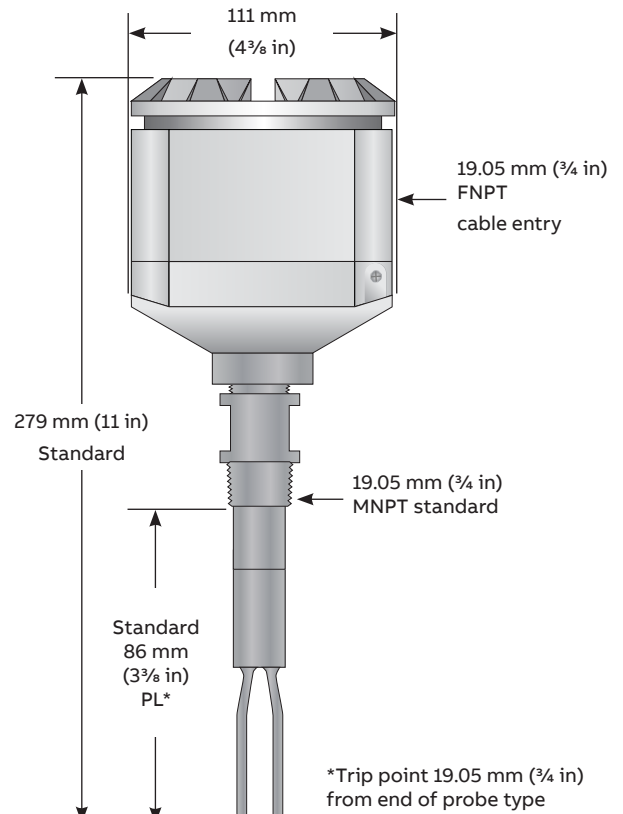

Figure 1

# ... 1 Description

## Sample applications

The RS85 can be used for level detection in tanks, vessels or piping containing all types of hot or cold liquids and is suitable for high/low level detection applications in hazardous areas. The RS85 can be mounted in any orientation. In vertical applications where room allows, the unit can be extended into the vessel (up to 84 in) with an extension tube. The RS85 is also available with Teflon coatings or alloy wetted parts for use in corrosive fluid and sticky applications.

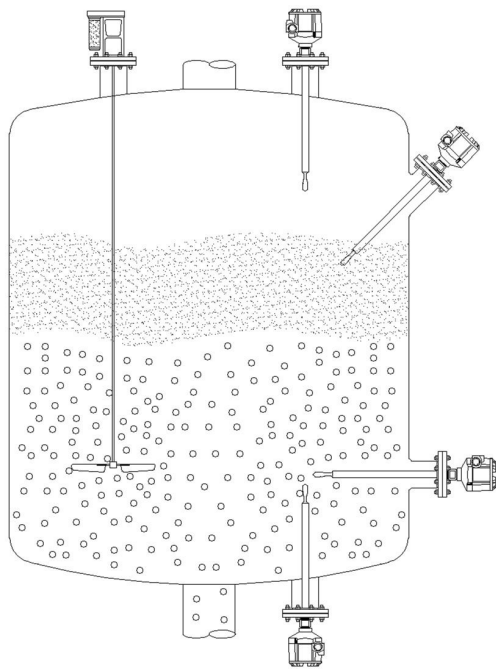

Figure 2

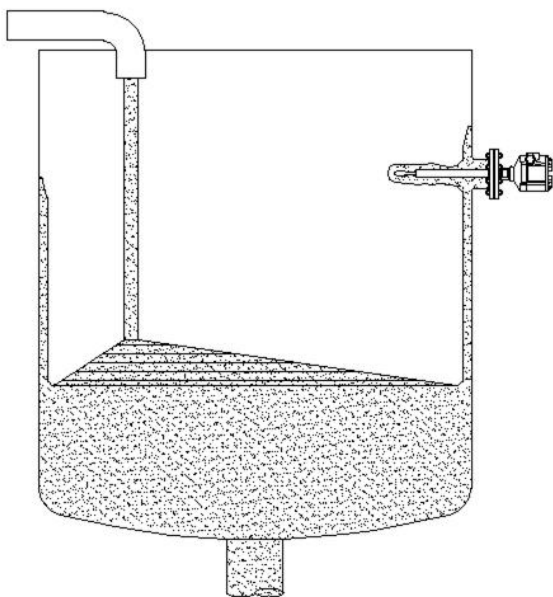

Figure 3

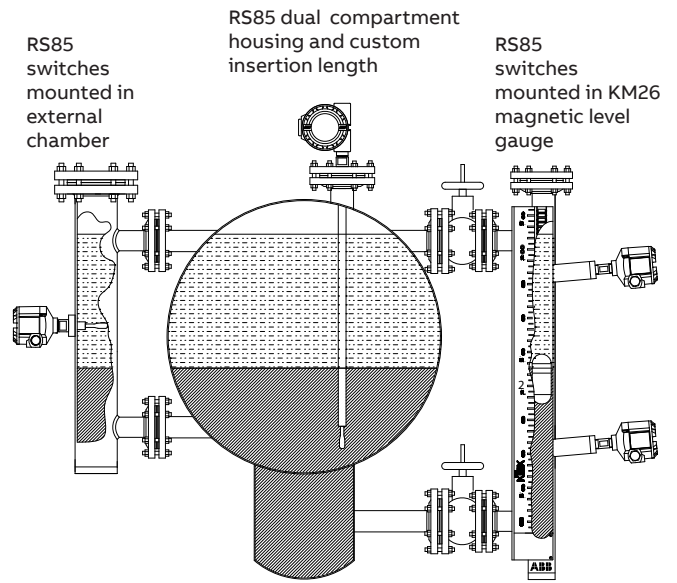
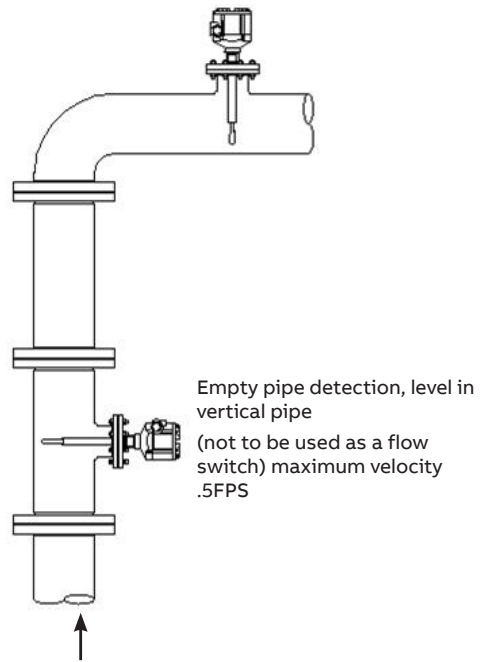

Figure 4



Empty pipe detection, level in vertical pipe  
(not to be used as a flow switch) maximum velocity .5FPS

Figure 5

## 2 Installation

### Mounting

After unpacking the unit, inspect it for any evidence of shipping damage. Inspect the fork tines to insure that they are not bent. Forks should be parallel to each other. Any claims for damage due to shipping must be filed with the carrier who handled the package (s).

- Select a mounting location for the switch and the sensor probe. Your unit may be an integral mounting option or the remote mounting option. The integral mounting unit consists of a single enclosure that includes the electronic module and the sensor probe. The remote mounting unit consists of two enclosures, one containing the electronic module and the other containing the sensor probe.
- Be sure that there is sufficient clearance around the mounting position to allow for the turning radius of the switch or remote sensor enclosure as the unit is screwed into place. Allow sufficient room above the vessel entry to be able to insert the probe into the opening of the vessel.
- The standard size of the threaded vessel coupling is  $\frac{3}{4}$  in NPT for most probes. Other size threaded connections or flanges are also available.
- Install and tighten threaded process connection switches with a spanner wrench on the wrench flats of the threaded connection.

### **i** NOTE

**Do not rotate switch housing on process connection. Switch performance may be affected.**

- The information included on the enclosure label should be visible. If necessary clean the label using a cloth soaked with either water or isopropyl alcohol.

### Tank mounting

The RS85 can be mounted for high or low level detection using a flange or the standard  $\frac{3}{4}$  in NPT connection.

### Switch point and mounting position

Switch points on the sensor depend on the mounting position. The switch point is determined by the position of the tuning fork.

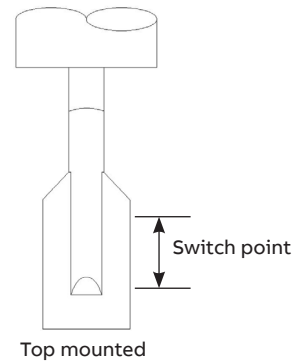

Figure 6

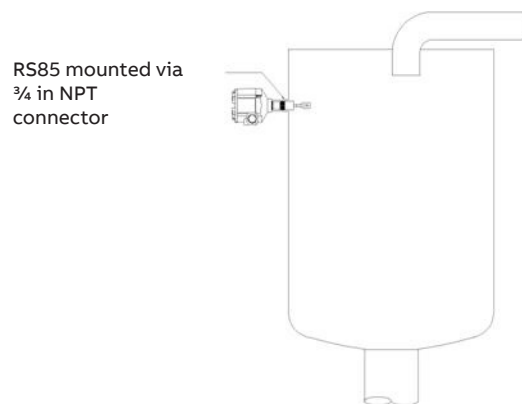

Figure 7

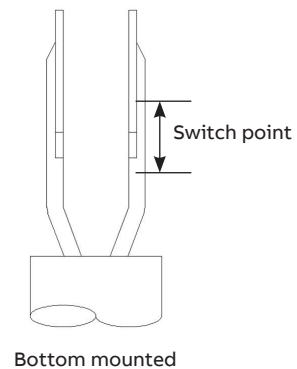

Figure 8

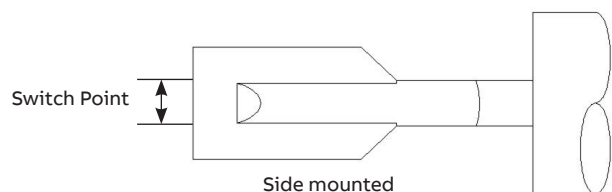

Figure 9

## 2 ...Installation

### Mounting for vessel wall build-up

If there is a potential for build-up on the vessel wall, mount the RS85 with sufficient distance between the wall and the fork assembly to prevent bridging.

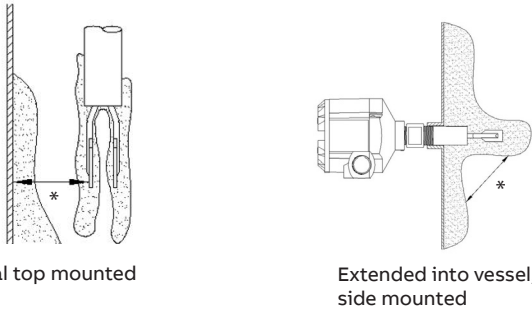

Figure 10

\*Ensure that there is sufficient distance between the build-up expected on the tank and the forks.

### Extended Probe Lengths (PL)

The sensor length 'PL' for the RS85 will differ based on the process connection. A threaded sensor PL is measured from the bottom process thread to the tip of the fork tine. A flanged sensor PL is measured from the face of the flange to the tip of the fork tine.

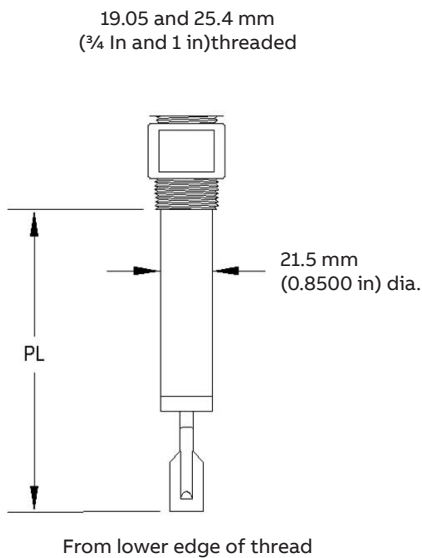

Figure 11

### Mounting position with extension tubes

If ordering the RS85 with an extended probe length, ensure there is adequate space between outside walls or ceilings and the vessel mounting point

A short extended probe length (up to 20 in) can be mounted in any orientation. An RS85 with an extended probe length over 20 in (up to 84 in) must be mounted vertically.

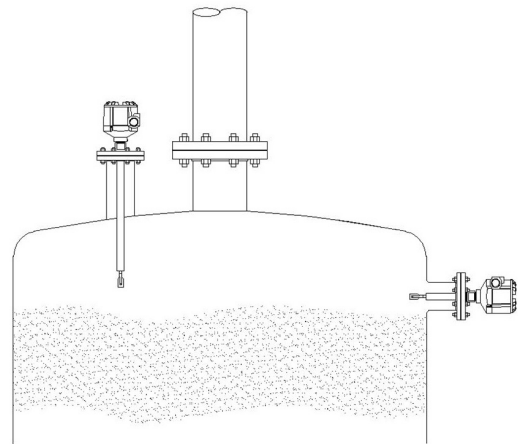

Figure 12

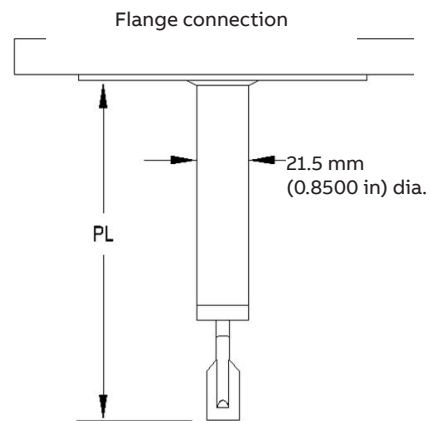

Figure 13

## 2 ...Installation

### Mounting for high viscosity liquids

High viscosity liquids require proper mounting to ensure accurate, repeatable service. With high viscosities, the optimum mounting is vertical from the vessel top or horizontal (flush mounted from the side).

Note: Horizontal mounting: Position the forks so that the narrow edge of the tines are vertical. This ensures that the liquid or gelatinous process can run off easily.

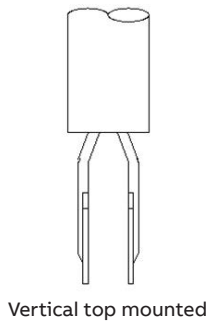

### Mounting for low viscosity liquids

Mounting positions for low viscosity liquids are shown below. If the RS85 fork is nozzle mounted with a flange and does not extend beyond the wall of the vessel, a minimum nozzle diameter of 2 in is required. If mounted into a threaded nozzle, forks should protrude past the wall of the vessel.

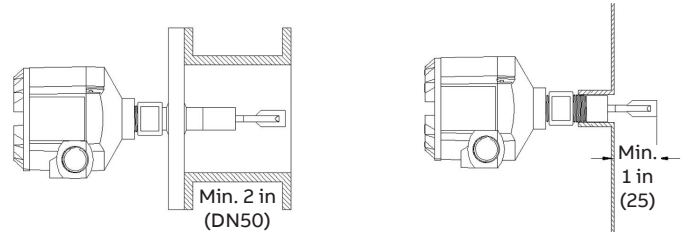

\* Deburr the nozzle surfaces

Figure 15

### Pipe mounting and empty pipe detection

The RS85 can be mounted into pipe lines of 2 in and larger diameters.

Note: To avoid blockage of the flowing material, ensure narrow edge of forks is parallel with pipe walls.

To maintain optimum performance in flow or no flow applications, the liquids should have low viscosities and low flow velocities. (less than .5 FPS)

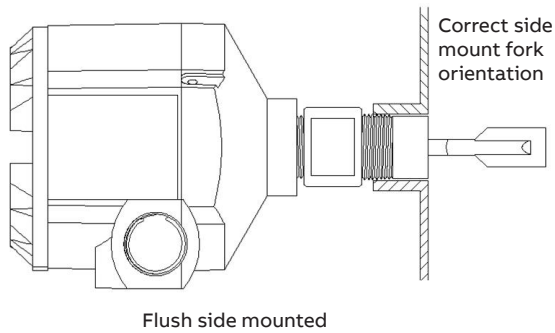

Figure 14

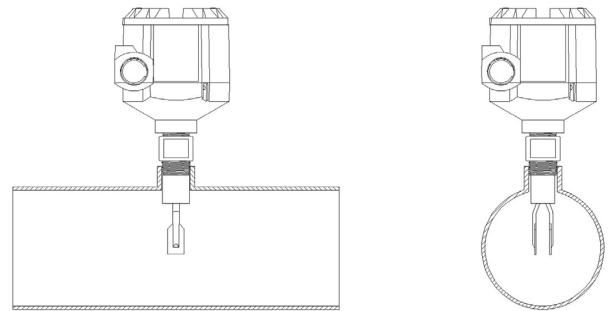

Figure 16

Empty pipe detection

## 2 ...Installation

### ⚠ CAUTION

When making the opening in the vessel, observe all safety requirements of the area in which the work is being done. Be especially careful when working with pressure vessels.

The Model RS80/RS85 unit may not work properly if:

- there is a conductive bridge between the paddles of the fork.
- the fork tines are not in vertical position.
- there is a high turbulence level
- probe is located near a material fill line.
- probe is mounted improperly.

The model RS80/RS85 unit may be damaged if:

- temperature in the housing exceeds appropriate limits.
- the process temperature exceeds probe's operating limits.
- the electronic module is subjected to excessive vibration or shock.
- vessel pressure exceeds process operating pressure rating of probe.
- probe is located near a material fill line.

If any of the above statements apply to your application, do not install the switch until you contact your local representative or the ABB factory for further instructions.

## Integral and remote units

### Integral units

- Install the switch into the vessel coupling and connect conduit between the switch and the power supply source as required.
- Be sure the conduit is suitable for the environment in which the units are to be used.

### Remote units

- Install the remote sensor probe into the vessel coupling. Select a suitable location for the instrument housing that allows convenient access for calibration and meets environmental conditions of the unit.
- Connect conduit between the remote sensor housing and the instrument housing.
- Connect the RG62 type coaxial cable assembly supplied with the unit from the remote probe to the instrument input.
- Connect conduit between the switch and the supply source as required (figure 17 and 19). Be sure the conduit is suitable for the environment in which the units are to be used.

### ⚠ CAUTION

Due to the extremely wide range of control and/or alarm applications in which the unit may be used, it is not possible to show all conceivable wiring diagrams. Consult your representative or factory if further assistance is needed.

## Caution

Be sure that all wiring and conduit conforms to the requirements of the National Electrical Code and any enforcing authorities or agencies having jurisdiction over the installation. Be sure that any special conditions, such as hazardous area locations, are given full consideration.

- After installation and wiring, it is necessary to set-up the unit to the particular vessel and material that will be measured, using the standard calibration procedure.
- The Resonator Vibrating Switch is designed to monitor levels of liquid products with a viscosity not greater than 1000 cp.

### i NOTE

A) All field wiring connected to the RS85 switch must comply with applicable National Electric Code or applicable guidelines.

B) Do not use the switch on vessels with operating temperatures above 200 °F without having the high temperature option (all Teflon insulation).

C) Any conduit or fittings in close proximity to a magnetically activated switch should be aluminum or some other non-magnetic material. This is necessary to avoid interference with the operation of the magnetically activated reed switches.

D) Unit is designed for installation in an overvoltage category 1, pollution degree 2, as outlined by section 6 of the IEC 1010 standard.

E) The maximum altitude of operation is 6560 ft (2000 m).

F) Protective grounding: The level switch is equipped with grounding screw locations, both internal and external of the housing.

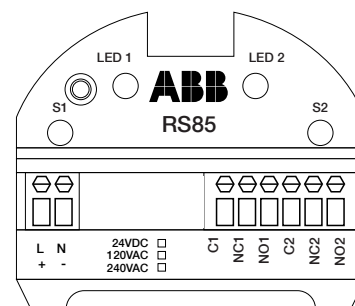

Figure 17



## 2 ...Installation

### Installation requirements (Ex d):

The RS85 is intended for mounting in the boundary of a zone 0 and zone 1 hazardous area

When the HT6 – High temperature extension option is used both the enclosure and the HT6 adapter must be entirely located in zone 1.

The RS85 must be installed in accordance with an appropriate code of practice such as EN/ IEC 60079–14.

Flameproof joints are not intended to be repaired.

Cable entry temperatures may reach 80 °C. Use field wires suitable for this temperature.

Cable or conduit entries must be fitted with a suitably certified cable entry device with or without the use of a suitably approved thread adaptor, where conduit is used a suitably approved stopping box shall be provided immediately on the entrance of the enclosure.

Unused cable entry holes shall be closed by a suitably approved Ex d blanking plug.

Temperature classes are based on the following table in relation to the maximum process temperature:

Table 1	
Maximum process temperature	Temperature class
≤ 50°C	T6
≤ 66°C	T5

### Markings

ABB K-TEK PRODUCTS	
MODEL NO:	
SERIAL NO:	
TAG NO:	
MAX TEMP - HOUSING: 158°F; SENSOR:	
WORKING / MAX PRESSURE:	
<b>CAUTION: DO NOT OPEN WHEN EXPLOSIVE ATMOSPHERE IS PRESENT</b>	
 APPROVED NEMA 4X MADE IN USA	CL I, DIV 1, GRPS A,B,C,D CL II, DIV 1, GRPS E,F,G. CL III, T6 AT 70°C AMBIENT CONDUIT SEAL NOT REQUIRED SEE MANUAL WARMINSTER PA 18974
	SINGLE SEAL TAG0121

Figure 18

### 3 Setup (Configuring Switch)

#### Accessing setup adjustments



Figure 19

Setup of the RS85 may be achieved using a (1) magnet (provided with switch) positioned on the housing or (2) by means of the pushbuttons on the module. In the following operations, pushbuttons (Figure 19) will correspond to magnet positions (Figure 20) as follows:

- S1 position = S1 button only
- S2 position = S2 button only
- X position = S1 and S2 simultaneously

During normal operation, LED1 will light either RED or GREEN based on the settings of the switch.

#### Initial setup instructions:

##### Step 1: RS85 (resets to factory defaults)

Power up the electronic module with it disconnected from the fork assembly (Figure 21). Press S1 and S2 buttons of the electronic module and hold for several Seconds while a sequence of red and green lights display ending with LED1 RED (Figure 21). The RS85 electronic module is now set to factory defaults. Re-install the electronic module in the fork assembly.



RS85 magnet position label

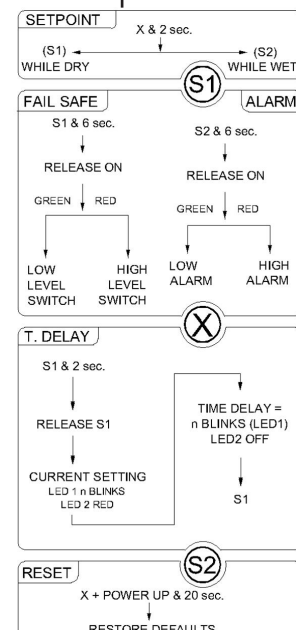

Figure 20

### 3 ...Setup (configuring switch)

#### Factory default settings/reset

Each RS85 will be supplied with the following factory default settings:

Fail safe mode = high  
Time delay = instant  
Set points = factory defaults

#### **i** NOTE

To restore the default settings, always remove the electronic module from the fork assembly. Then with power connected to the electronic module Press S1 and S2 buttons of the electronic module (figure 21) and hold for several seconds while a sequence of red and green lights display ending with LED1 RED. Re-install the electronic module in the fork assembly.



Figure 21

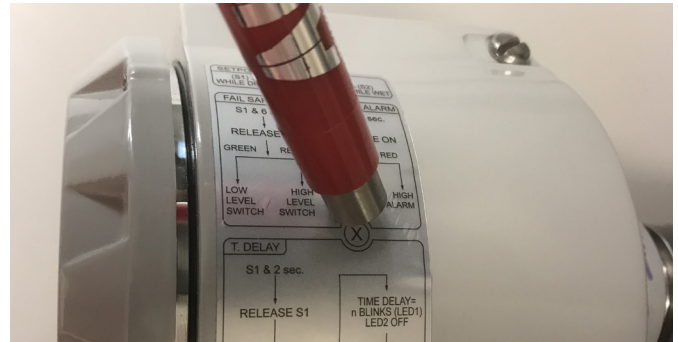

Figure 22



Figure 23

On Initial installation it is recommended that the RS85 be calibrated to the process conditions/connection. The purpose is to establish a dry frequency threshold value reference.

#### **Step 2:** Calibrating to the process conditions/connections

With the vibrating fork installed (via. the process connection) and under dry fork condition power up the unit. Press S1 and S2 buttons of the electronic module simultaneously (Figure 23) or hold magnet on 'X' of the magnet position label (Figure 22) for several Seconds. A sequence of red and green lights will display ending with LED1 GREEN. The RS85 vibrating fork switch is now configured to operate under process conditions.

#### **i** NOTE

The module should be reset to factory defaults (step 1) always before the module is calibrated to process conditions.

### 3 ...Setup (configuring switch)



Figure 24

Fail safe	Relay state (led)	
	Dry fork	Wet fork
Low level switch (fail safe low)	Off (red)	On (green)
High level switch (fail safe high)	On (green)	Off (red)
Default setting		

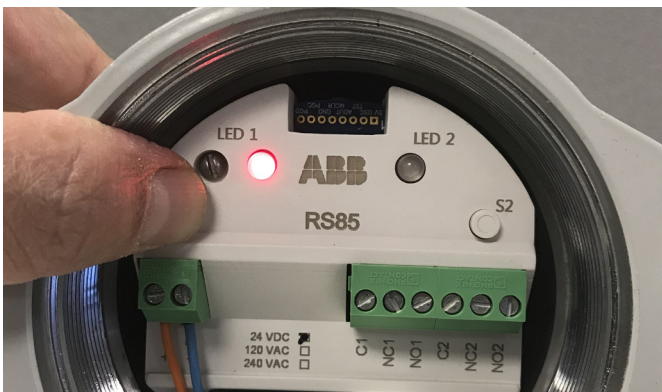

Figure 25

### Fail safe/relay operation

A fail safe relay operation is used to energize the relay when the switch is in normal condition. This will indicate that the switch has power. Therefore in a fail safe high application, the relays will be energized when the level is below the switch (dry fork) and de-energized when the level is above the switch (wet fork). Likewise, setting the switch Fail Safe to Low will cause the relays to be energized when the level is above the switch (wet fork) and de-energize when the level is below switch (dry fork). The default setting for the fail safe or relay operation of the resonator is high. To change the fail safe operation for the relays, place the magnet in the S1 position (Figure 24) or press pushbutton S1 (Figure 25) for 5 seconds. LED1 will change back and forth from red to green. Removing magnet on red will change fail safe to green (fail safe high). Removing magnet on green will change fail safe to red (fail safe low). Should power be lost, the relay will de-energize.



## 4 Time delay

The RS85 time delay option allows changing the time response of the relay output, which is very useful in applications with severe turbulence or agitation.

In typical applications, the RS85 in default settings will activate the relays instantaneously when the switch point has been reached. In certain applications it may be necessary to delay the action of the relays in the switch. If this is desired, a time delay for the relays can be set. To enter the time delay setup mode, place the magnet on 'S1' (figure 26) or press pushbutton S1 (figure 27) for more than 1 second but less than 6 seconds. The following sequence of LED's will be observed:

**Table 3 – Time delay adjustment**

OPERATION	LED 1	LED 2
Normal	Green or red	Off
S1 for 1 – 6 sec	Off	Off
Displaying current time delay	'Green'	Red
	Off	Off
S1 PER table 4	'Green'	Off

'.' - indicates a blinking LED

**Table 4 – Time delay setting**

LED1 Blinks	1	2	3	4	5	6	7	8
	0	5	10	15	20	25	30	35

While LED2 is lit RED, LED1 will blink the current time delay setting per table 4.

After LED2 turns 'off', LED1 will blink in correspondence to the different time delay settings per table 4. When the desired time delay is reached, place the magnet on the 'S1' position (see figure 26). The time delay will be set and the RS85 will return to normal operation. If a time delay is not selected, the RS85 will return to its current operating mode without changing the current time delay setting. During normal operation of the switch, if a time delay is selected, LED1 will change color when the switch point has been reached. The relays will respond after the elapsed time delay on both energized and de-energized actions.

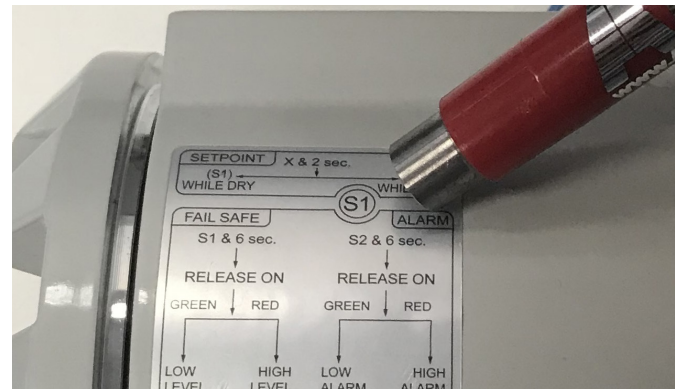

Figure 26



Figure 27

## 5 Troubleshooting

### Fault mode

If a fault is detected, either electrical or mechanical, LED 2 will blink in RED and the normal ON relay is de-energized. This LED is integral to the modular electronics and can only be seen through the glass viewing cover.

**Table 5 – Fault mode**

Fault	Reason	Remedy
Does not switch	No Power	Check power
	Faulty wiring	Check wiring
	Faulty electronic Module	Replace module
	Density of liquid too low	Confirm that density is above .5 SG
	Fork encrusted with too much buildup	Clean fork
Switches incorrectly	Fork corroded or bent	Exchange fork and process connection (requires sending to factory)
	Contacts welded together (after short-circuit)	Replace module; put fuse in contact circuit
	Fail-safe mode set wrong	Set correct mode at electronic module
Sporadic faulty switching	Relay switches on & off while in dry fork conditions	Recalibrate switch in process connection
	Thick heavy foam, very turbulent conditions, foaming liquid	Set time delay
	Extreme RFI	Use shielded cable
	Water in housing	Remove water, screw cover and cable gland tight
	Output overloaded	Reduce load: (cable) capacitance

### Standard single compartment dimensions

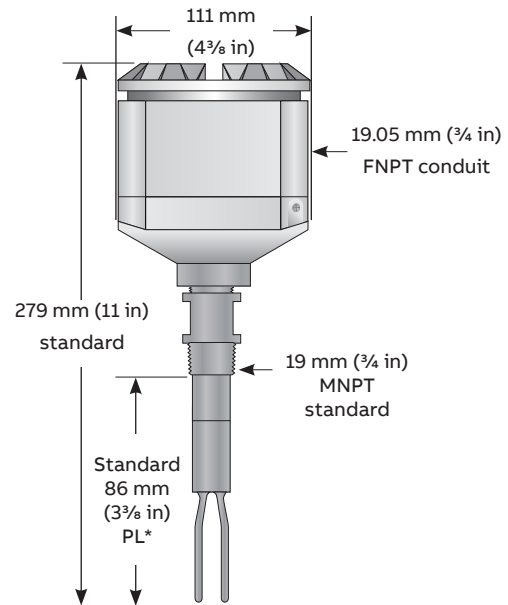

Figure 28

### Resonator sample applications

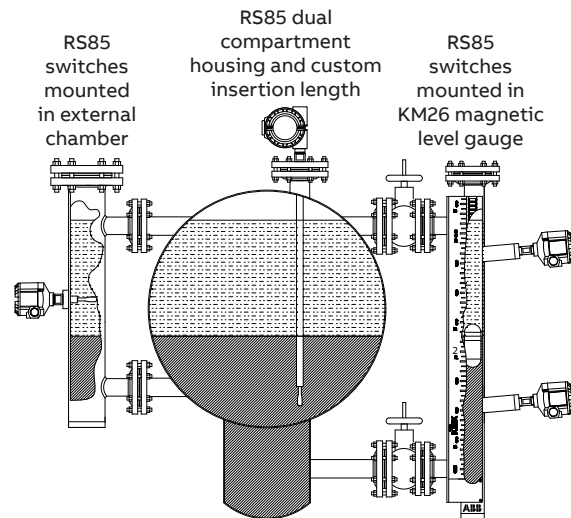

Figure 29

## 6 Warranty statement

### 5 YEAR WARRANTY FOR:

KM26 Magnetic Liquid Level Gauges; MagWave Dual Chamber System; LS Series Mechanical Level Switches (LS500, LS550, LS600, LS700, LS800 & LS900) (does NOT include switching mechanisms, ie. MS30, MS40, MS41, PS35 & PS45); EC External Chambers, STW Stilling Wells and ST95 Seal Pots.

### 2 YEAR WARRANTY FOR:

AT100, AT100S and AT200 series transmitters; RS85 liquid vibrating fork switches; TX & TS, thermal dispersion switches; IR10 and PP10 External Relays; MT2000, MT5000, MT5100 and MT5200 radar level transmitters; RI100 Repeat Indicators; KP paddle switches; A02 & A75 RF capacitance level switches; Buoyancy Level Switches (MS50, MS10, MS8D & MS8F); Magnetic Level Switches (MS30, MS40, MS41, PS35, PS45 and LMS100).

### 1 YEAR WARRANTY FOR:

AT500 and AT600 series transmitters; LaserMeter and SureShot series laser transmitters; LPM200 digital indicator; DPM100 digital indicators; APM100 analog indicators; KVIEW series digital indicators and controllers; GRANUPOINT and SLUDGEPOINT vibrating fork switches, SOLITRAK Electro-Mechanical Continuous Measuring Devices, KSONIK ultrasonic level switches, transmitters & transducers, ChuteMaster Microwave Transmitter / Receiver and TiltMaster Switches.

### SPECIAL WARRANTY CONSIDERATIONS:

ABB Inc, K-TEK Products, does not honor OEM warranties for items not manufactured by ABB Inc, K-TEK Products, (i.e. Palm Pilots). These claims should be handled directly with the OEM.

ABB Inc, K-TEK Products, will repair or replace, at ABB Inc, K-TEK Product's, election, defective items which are returned to ABB Inc, K-TEK Products, by the original purchaser within the period specified above from the shipment date of the item and which is found, upon examination by ABB Inc, K-TEK Products, to its satisfaction, to contain defects in materials or workmanship which arose only under normal use and service and which were not the result of either alterations, misuse, abuse, improper or inadequate adjustments, applications or servicing of the product. ABB Inc, K-TEK Products's, warranty does not cover the repair or replacement of units that fail from the effects of excessive vibration unless the units are originally designed for vibration application. In addition, ABB Inc, K-TEK Products's warranty does not include on-site repair or services. Field service rates can be supplied on request.

If a product is believed to be defective, the original purchaser shall notify ABB Inc, K-TEK Products, and request a Returned Material Authorization before returning the material to ABB Inc, K-TEK Products, with transportation prepaid by the purchaser. (To expedite all returns/repairs from outside of the United States, consult ABB Inc, K-TEK Product's customer service team (service@ktekcorp.com) to determine an optimal solution for shipping method and turnaround time.) The product, with repaired or replaced parts, shall be returned to the purchaser at any point in the world with transportation prepaid by ABB Inc, K-TEK Products, for best-way transportation only. ABB Inc, K-TEK Products, is not responsible for expedited shipping charges. If the product is shipped to ABB Inc, K-TEK Products, freight collect, then it will be returned to the customer freight collect.

If inspection by ABB Inc, K-TEK Products, does not disclose any defects in material or workmanship, ABB Inc, K-TEK Product's, normal charges for repair and shipment shall apply (minimum 250.00 USD).

The materials of construction for all ABB Inc, K-TEK products, are clearly specified and it is the responsibility of the purchaser to determine the compatibility of the materials for the application.

THE FOREGOING WARRANTY IS ABB INC, K-TEK PRODUCT'S, SOLE WARRANTY AND ALL OTHER WARRANTIES EXPRESSED, IMPLIED, OR STATUTORY, INCLUDING ANY IMPLIED WARRANTY OF MERCHANTABILITY OF FITNESS FOR A PARTICULAR PURPOSE, ARE EXCLUDED AND NEGATED TO THE MAXIMUM EXTENT PERMITTED BY LAW. NO PERSON OR REPRESENTATIVE IS AUTHORIZED TO EXTEND ANY OTHER WARRANTY OR CREATE FOR ABB INC, K-TEK PRODUCTS, ANY OTHER LIABILITY IN CONNECTION WITH THE SALE OF ABB INC, K-TEK'S PRODUCTS. THE REMEDIES SET FORTH IN THIS WARRANTY ARE EXCLUSIVE OF ALL OTHER REMEDIES AGAINST ABB INC, K-TEK PRODUCTS. ABB INC, K-TEK PRODUCTS, SHALL NOT BE LIABLE FOR ANY CONSEQUENTIAL, INCIDENTAL, OR SPECIAL DAMAGES OF ANY KIND. ABB INC, K-TEK PRODUCT'S, SOLE OBLIGATION SHALL BE TO REPAIR OR REPLACE PARTS (FOUND TO BE DEFECTIVE IN MATERIALS OR WORKMANSHIP) WHICH ARE RETURNED BY THE PURCHASER TO ABB INC, K-TEK PRODUCTS.

## 7 ABB RMA Form



ABB Inc.  
 K-TEK Products  
 125 E. County Line Road  
 Warminster PA 18974-4995, USA  
 Tel: +1 215 674 6000  
 Fax: +1 215 674 7183  
 Email: ktek-service@us.abb.com

\*\*\* IMPORTANT CUSTOMER NOTICE: PLEASE READ PRIOR TO RETURNING PRODUCTS TO ABB\*\*\*

Be sure to include the Return Authorization (RA) number on the shipping label or package to the attention: Customer Service. A copy of this document should also be included with the packing list. ABB wants to maintain a safe work environment for its employees. In the event, the returned product or material has been in contact with a potentially hazardous chemical, per federal regulations, the customer must provide evidence of decontamination and the related chemical composition and characteristics. In order to expedite your return, please include the applicable Material Safety Data Sheets (MSDS) and decontamination tags by affixing these documents in close proximity to the shipment label for identification purposes.

Return Authorization Form	
Customer:	Date:
Contact Name:	Product:
Contact Email:	Serial No:
Contact Phone:	Job No:
Contact Fax:	Service Rep:

Completed by Customer	
Reason	
Problem Found: None	
Action: None	
Requested:	
Is expedited return shipping requested? <input type="checkbox"/> Yes	
If yes, please provide a purchase order or your shipper's account number (ex. FedEx or UPS). ABB pays return transport via standard ground shipments only.	
If purchase order is issued, a copy of purchase order must be included with return documentation.	
Is ABB authorized to repair items determined to be non-warranty? <input type="checkbox"/> Yes	
If yes, a copy of purchase order must be included with return documentation.	
Customer PO:	Account #:
Date:	
Has product been in contact with any potentially hazardous chemical? <input type="checkbox"/> Yes	
If yes, documentation product and forward MSDS to ABB, "ATTN: Customer Service"	

Return Repaired Product to Address	
Shipping Address:	Billing Address:
	Ship Via:



## Notes

## Notes

## Notes

---

**ABB Inc.**

**Measurement & Analytics**

125 E. County Line Road  
Warminster PA 18974–4995, USA

Tel: +1 215 674 6000

Fax: +1 215 674 7183

**ABB Inc.**

8940 Bluebonnet Blvd. – Suite 100  
Baton Rouge, LA 70810 USA

Tel: +1-225-408-0800

**[abb.com/measurement](http://abb.com/measurement)**



We reserve the right to make technical changes or modify the contents of this document without prior notice. With regard to purchase orders, the agreed particulars shall prevail. ABB does not accept any responsibility whatsoever for potential errors or possible lack of information in this document.

We reserve all rights in this document and in the subject matter and illustrations contained therein. Any reproduction, disclosure to third parties or utilization of its contents – in whole or in parts – is forbidden without prior written consent of ABB.  
© 2018 ABB