

DELTA

Kamerasysteme

Furnace Probe Camera System with Camera B/C1317F

Application and Scope of Supply

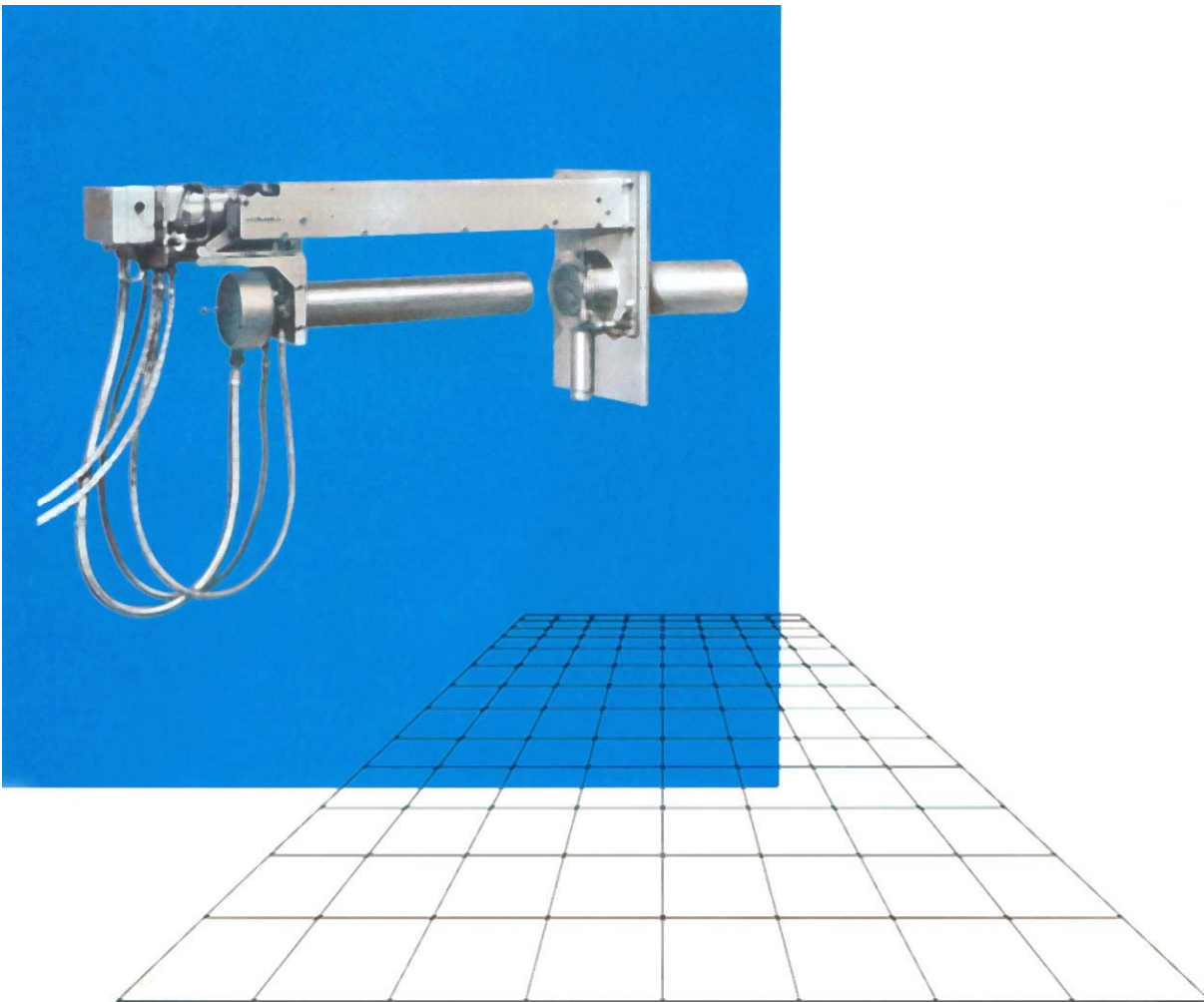

appl+scope-e



Contents

Contents

General

Application

- Furnace camera system for cement industry, rotary kiln and clinker cooler
- Furnace camera in power industry, burner, grate firing, slag run
- Furnace camera for waste combustion, grate firing, slag run
- Furnace camera in chemical industry, rotary kiln and secondary combustion chamber
- Furnace camera for glass industry, float glass line
- Furnace camera for heavy industry, melting process
- Plant surveillance, sample

Performance of camera systems

- Different methods, design and system performance for water cooled camera housings
- Different methods, design and system performance for air cooled camera housings
- Systems with camera retraction device, schematical diagram
- Systems without camera retraction device, schematical diagram
- Furnace camera systems with closed cooling water circuit (chiller)
- Installation options, camera with straight view
- Installation options, camera with elbow view

Data sheets

- Furnace probe camera C1317F
- CCD color camera C1317F
- Furnace probe lenses
- Probe camera housing, water cooled
- Probe camera housing, air cooled
- Accessories for fix installation of probe
 - Welding socket
 - Welding socket with cooling air supply
 - Transition piece
 - Mounting flange
 - Dummy flange
 - Air-barrier nozzle
 - Air-barrier valve
 - Tube and cable set
- Junction box
- Retraction device
- Control unit
- Cooling water unit
- Compressed air unit
- System accessories
 - Tube and cable set
 - Reversible flow filter
 - Cooling air switch
 - Compressed air switch
 - Thermometer with T-piece

Component list



General

The furnace probe cameras are used for the observation of furnaces and for monitoring annealing, combustion, melting, heating or sintering processes as well as material guidance in hot zones. The temperature at the probe tip is between 800°C and 2000°C in continuous operation; the pressure in the furnace may be between partial vacuum and an overpressure between 3 mbar and 100 mbar.

The furnace probe cameras consist of a CCD black-and-white or CCD color camera, a furnace probe lens and probe camera housing.

Two cameras are available:

- the CCD black-and-white camera B1317F with semiconductor image sensor, DC 12 V.
- the CCD color camera C1317F with semiconductor image sensor, DC 12 V power supply, automatic or manual white balancing on the camera.

The cameras can be equipped with:

- 1/3-inch probe lens with video-signal-controlled aperture, for the straight viewing direction with three different angles of view or for elbowed viewing direction, with replaceable filters for increasing the contrast and adaptation to the lighting conditions inside the furnace.

-Probe camera housing made of nickel-chromium steel or titanium, double-walled for cooling water and purging air, straight or elbowed view direction, temperature monitoring in the tip, with V-flange for accurate installation.

The furnace CCTV system are available in two different versions:

- System without a retraction device
- System with a retraction device for the furnace probe camera.

Systems with camera retraction device

For automatic retraction of the probe camera out of the furnace in the event of faults in the media supply; can be used for furnace pressures ranging from partial vacuum up to 10 mbar overpressure and temperatures up to 2000°C at the probe tip.

The following mounting accessories are available:

Hose and cable set, installation hose set, control unit or control unit/power supply unit, compressed air unit for working air and purging air, cooling water unit for the cooling water in the camera housing, reversible flow filter, thermometer with T-piece for water outlet temperature, cooling air switch for lock chamber or air nozzle version for use in overpressure furnaces.

Systems without camera retraction device

For fixed installation of the probe camera in the furnace wall; suitable for furnaces pressure ranging from partial vacuum up to 3 mbar overpressure and temperatures up to 800°C (in case of cooling air at a higher temperature in the camera cannot be removed in time).

The following mounting accessories are available:

Weld-in socket, cooling air switch, dummy flange, mounting flange, transition pipe; for over pressure furnaces: barrier air nozzle and valve, thermometer with T-piece, junction box with pressure monitor, hose- and cable set, cooling water unit, reversible flow filter, compressed air unit or compressed air switch to cooling dryer.

Note:

This document may not be duplicated nor its contents used or communicated to others without express authority.

Delivery to subject to availability; right of technical modifications reserved.



Application

Application

- Furnace camera system for cement industry, rotary kiln and clinker cooler
- Furnace camera in power industry, burner, grate firing, slag run
- Furnace camera for waste combustion, grate firing, slag run
- Furnace camera in chemical industry, rotary kiln and secondary combustion chamber
- Furnace camera for glass industry, float glass line
- Furnace camera for heavy industry, melting process
- Plant surveillance, sample

control room

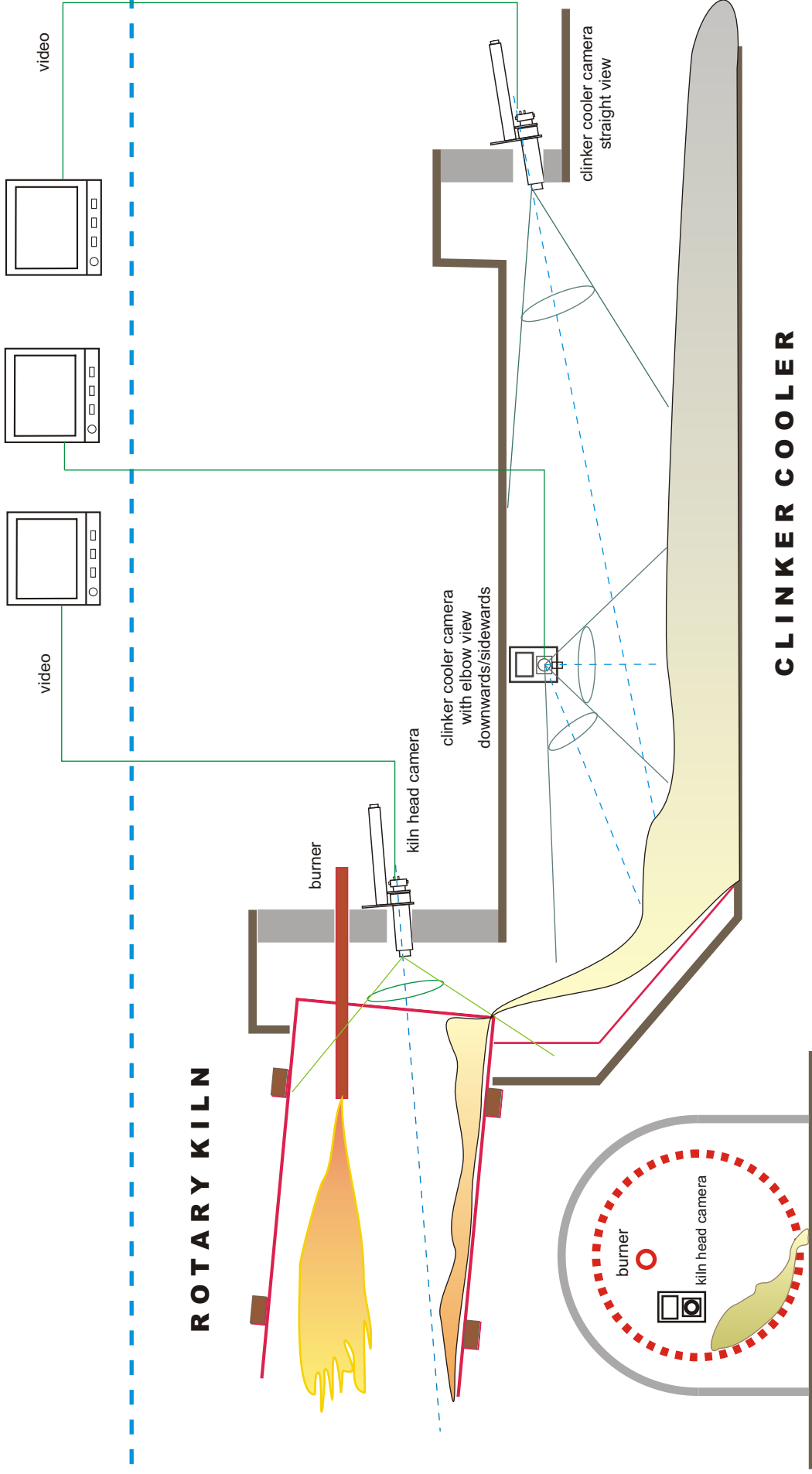

ROTARY KILN

CLINKER COOLER

view: rotary kiln, kiln head

Furnace Camera System for Cement Plant

Surveillance, Monitoring of Rotary Kiln and Clinker Cooler

Delta Kamerasysteme
Frankfurt / Main

BSP-CEM-01-E

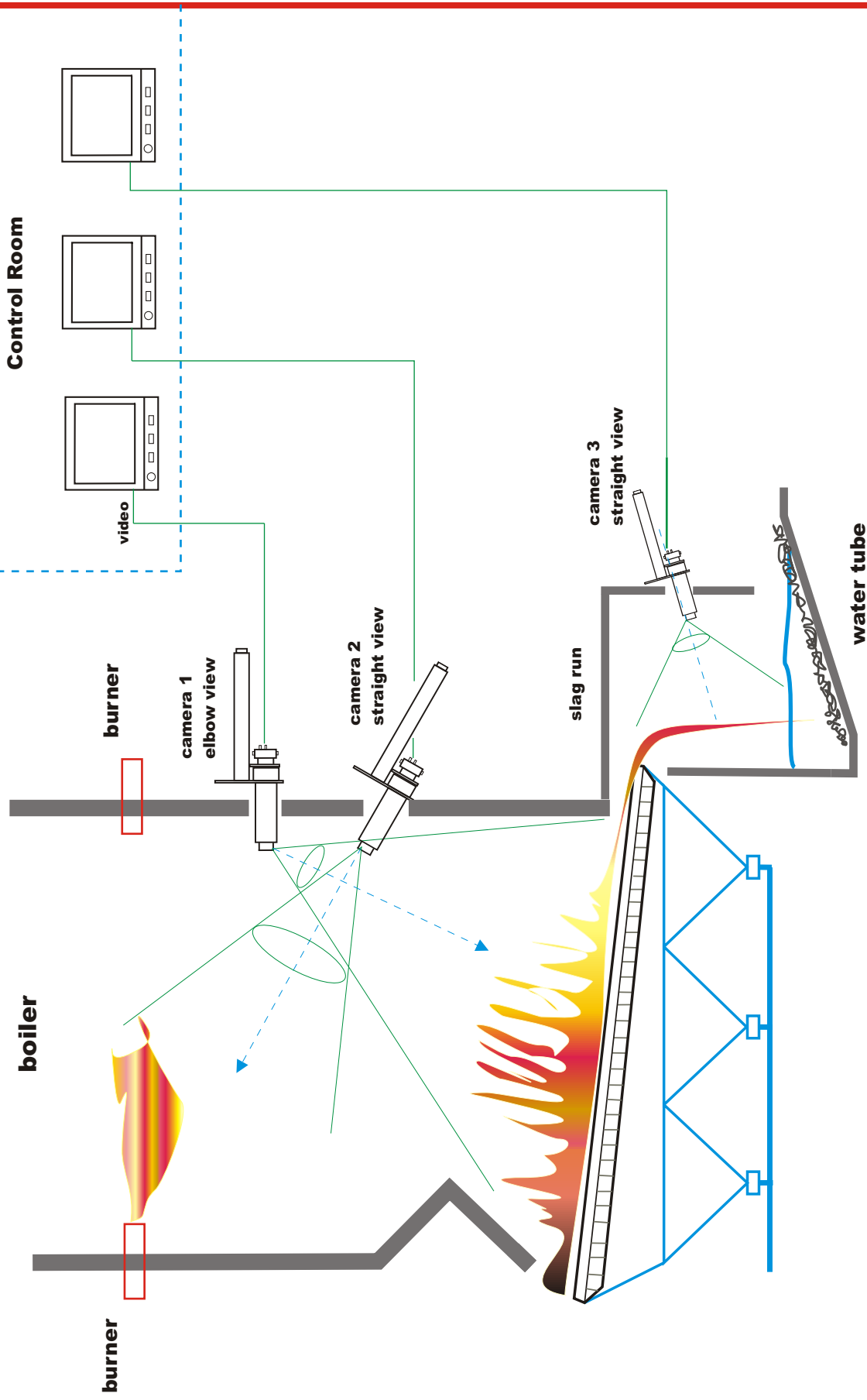

Furnace Camera System in Power Industry
Monitoring of Burner, Grate Firing and Slag Run

Delta Kamerasysteme
 Frankfurt / Main

BSP-KRA-01-E

control room

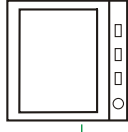

video

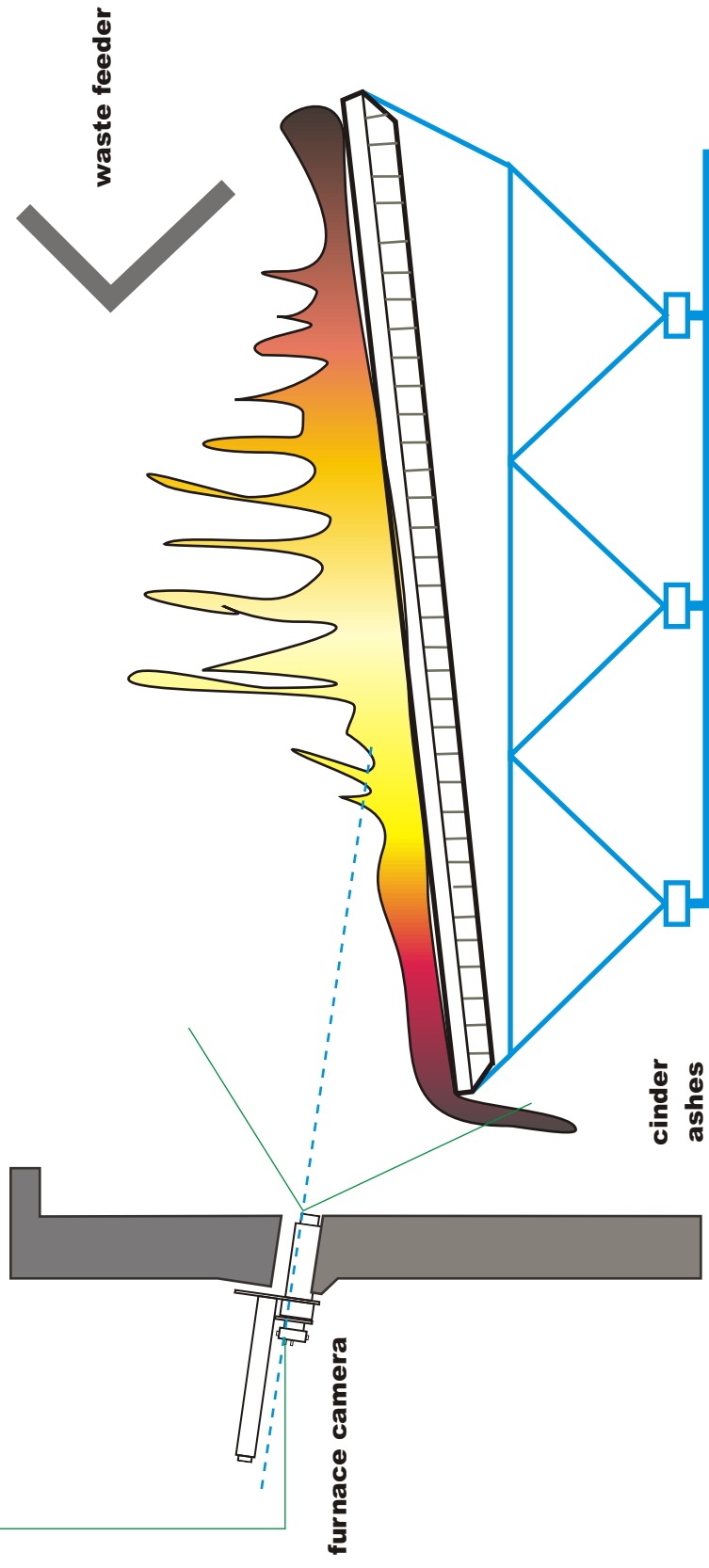

Furnace Camera System for Waste Combustion Process

Monitoring, Observation of Combustion Chamber

Delta Kamerasysteme

Frankfurt / Main

BSP-MVA-01-E

Control Room

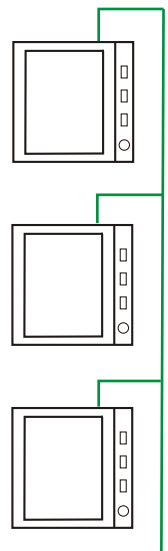

video

Front view

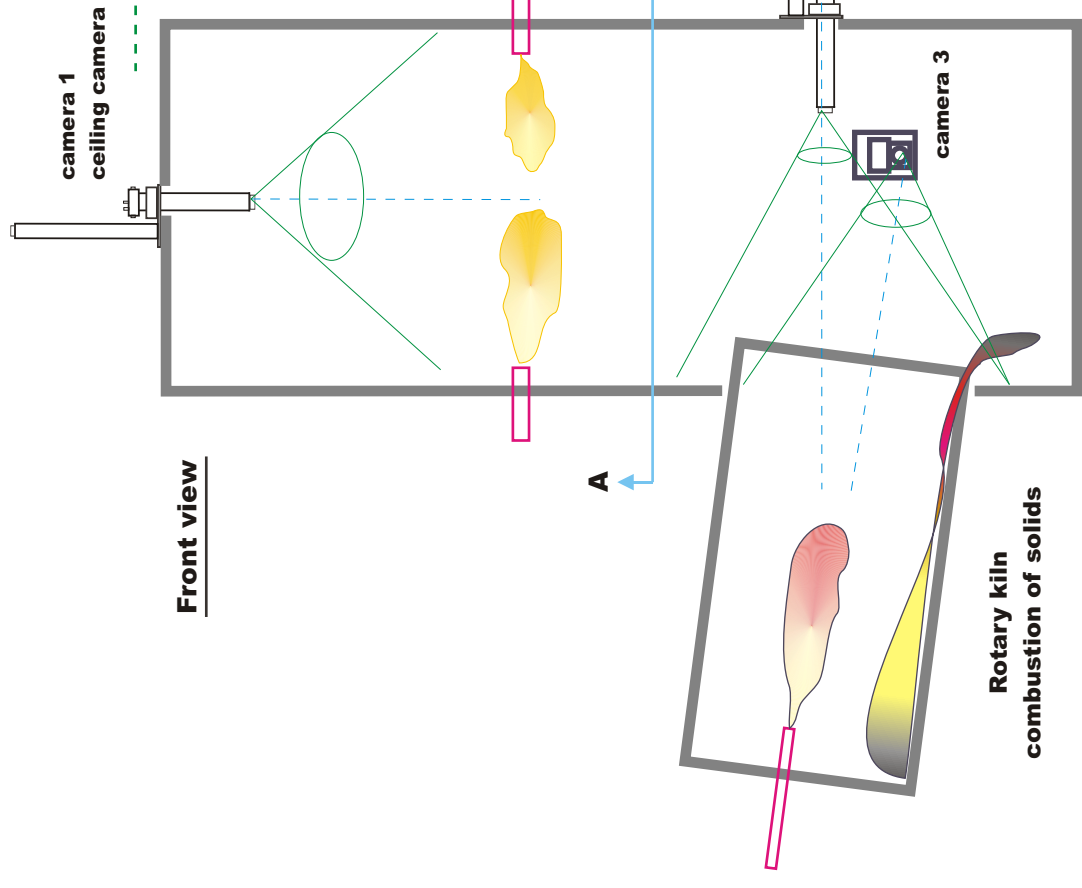

View from top, section A-A

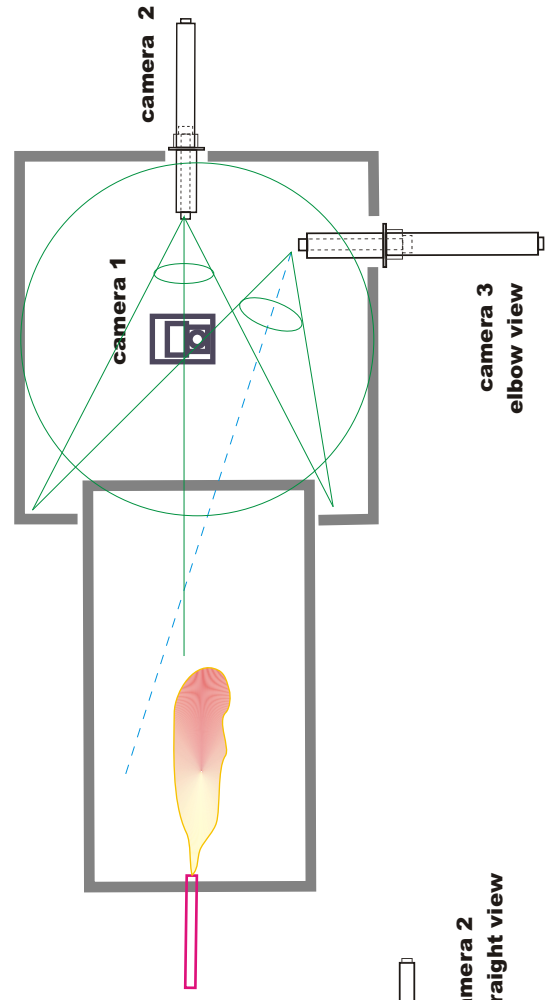

Vessel
combustion of liquids

Rotary kiln
combustion of solids

Furnace Camera System in chemical Industry

Monitoring, Observation of Combustion Processes of chemical Residuals

Delta Kamerasysteme
Frankfurt / Main

BSP-CHE-01-E

control room

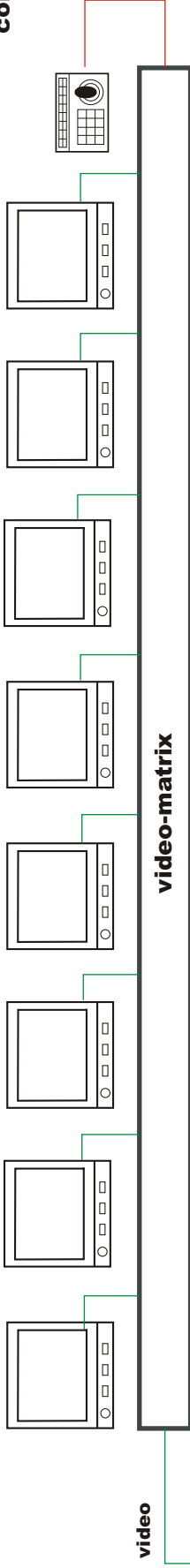

video

video-matrix

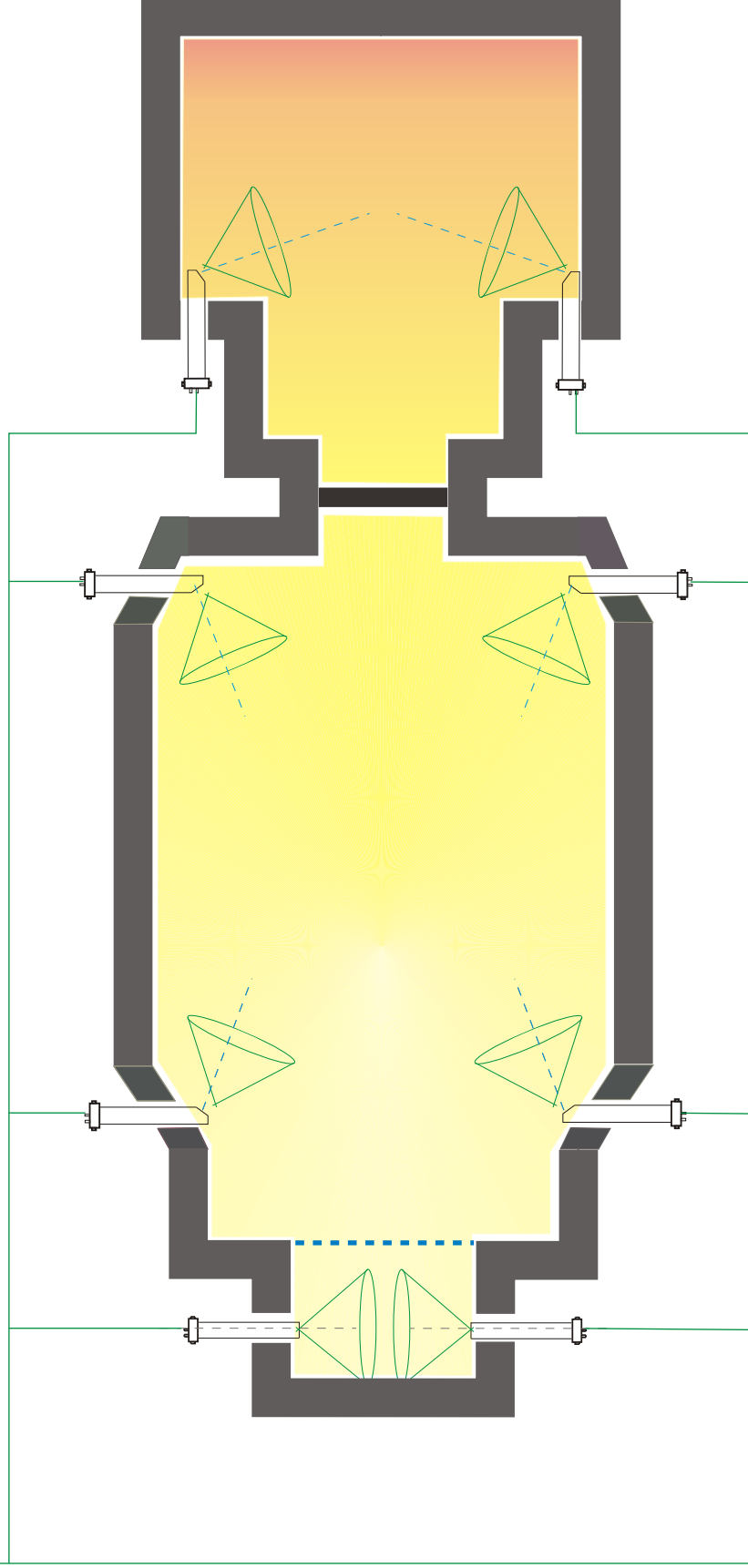

float-bath

oven

Monitoring, Observation of a Float Glass Line

Furnace Camera System in Glass Industry

BSP-GLA-01-E

Delta Kamerasysteme

Frankfurt / Main

control room

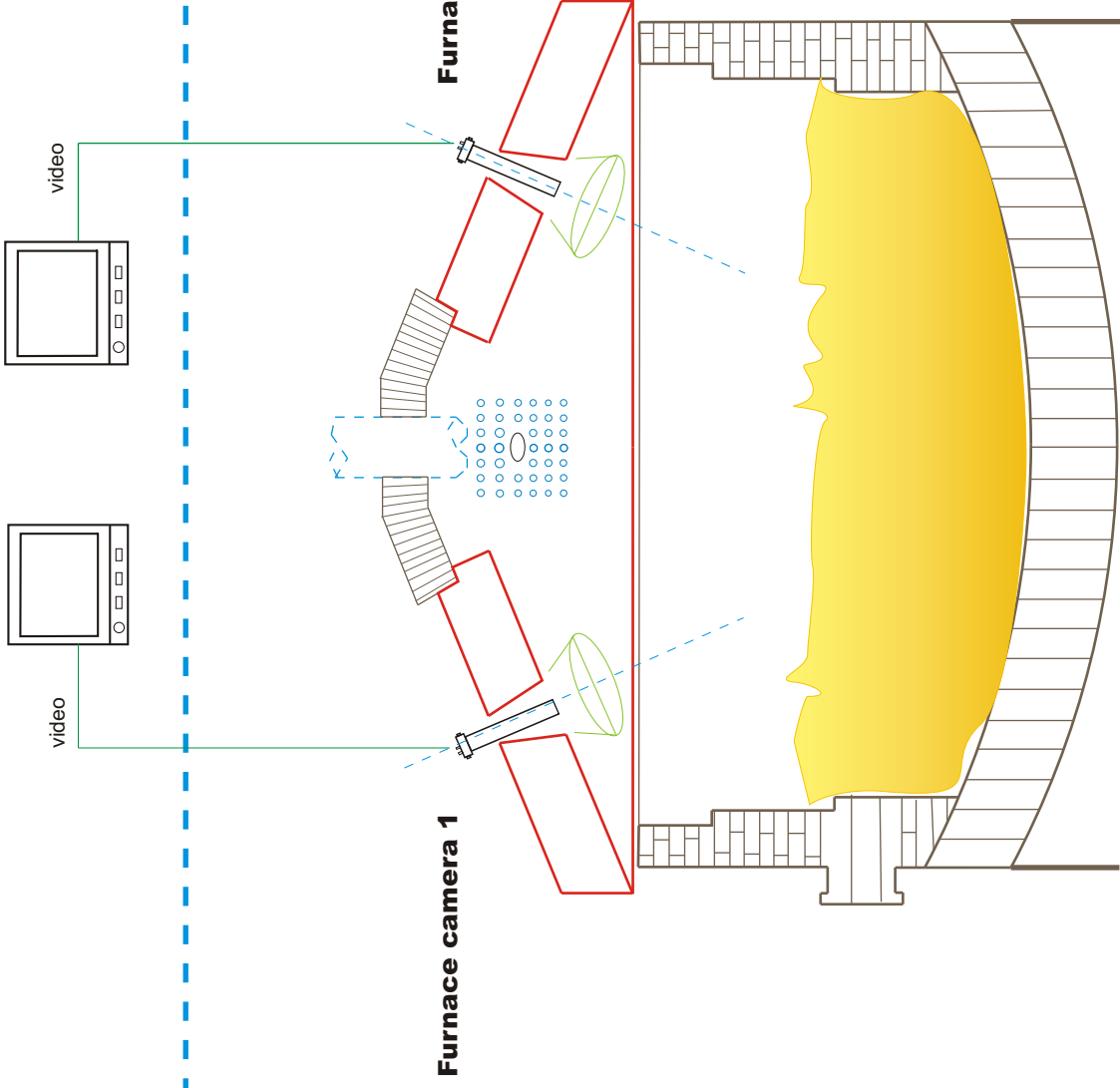

BSP-SME-01-E

Furnace Camera Systems in Heavy Industry
Monitoring, Observation of Melting Furnace

Delta Kamerasysteme
Frankfurt / Main

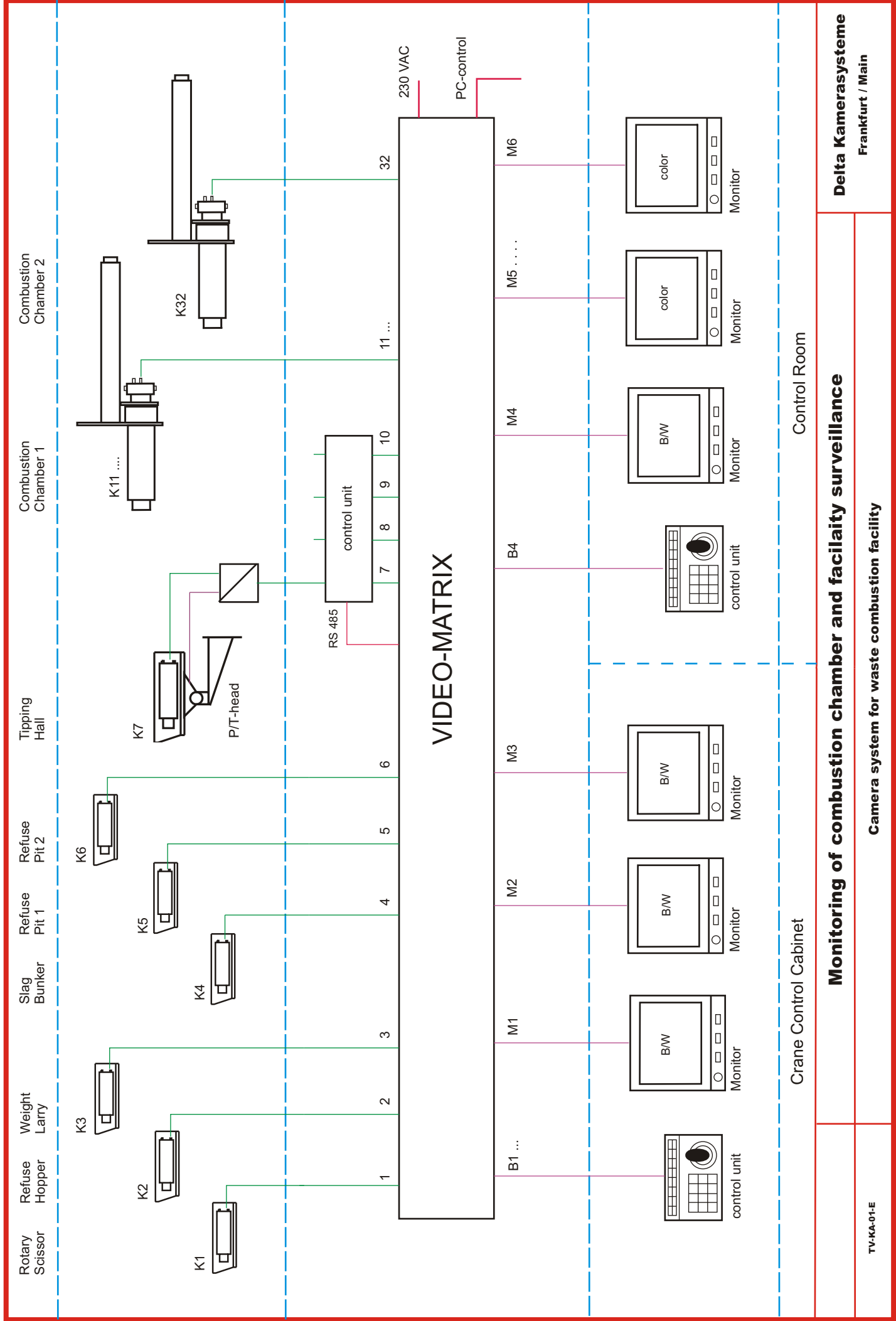

Monitoring of combustion chamber and facility surveillance

TV-KA-01-E

Camera system for waste combustion facility

Delta Kamerasysteme
Frankfurt / Main

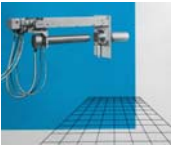

Performance of camera systems

Performance of camera systems

- Different methods, design and system performance for water cooled camera housings
- Different methods, design and system performance for air cooled camera housings
- Systems with camera retraction device, schematical diagram
- Systems without camera retraction device, schematical diagram
- Furnace camera system with closed cooling water circuit (chiller)
- Installation options, camera with straight view
- Installation options, camera with elbow view

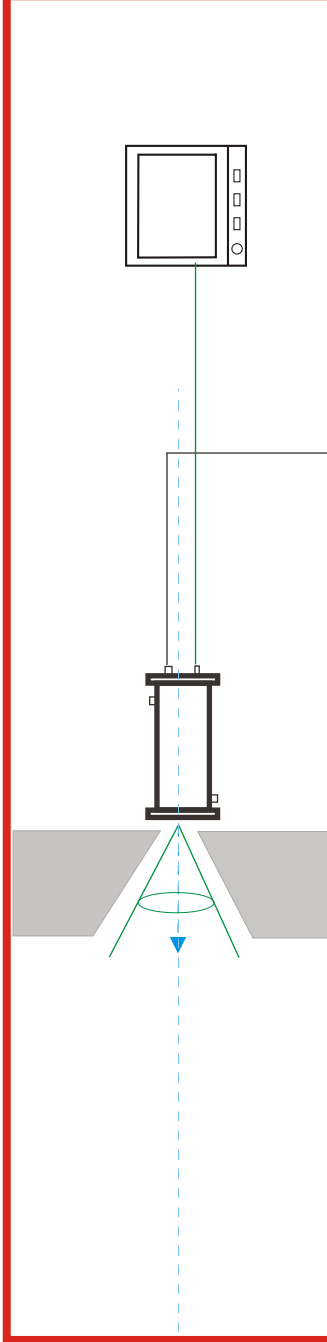
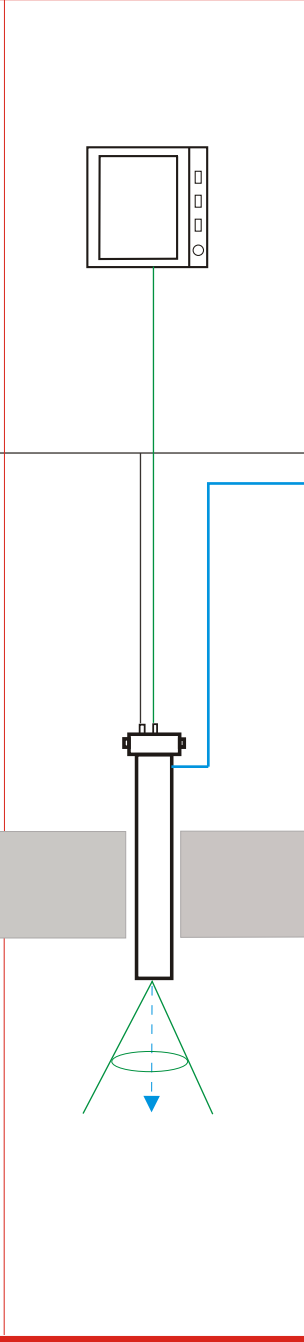
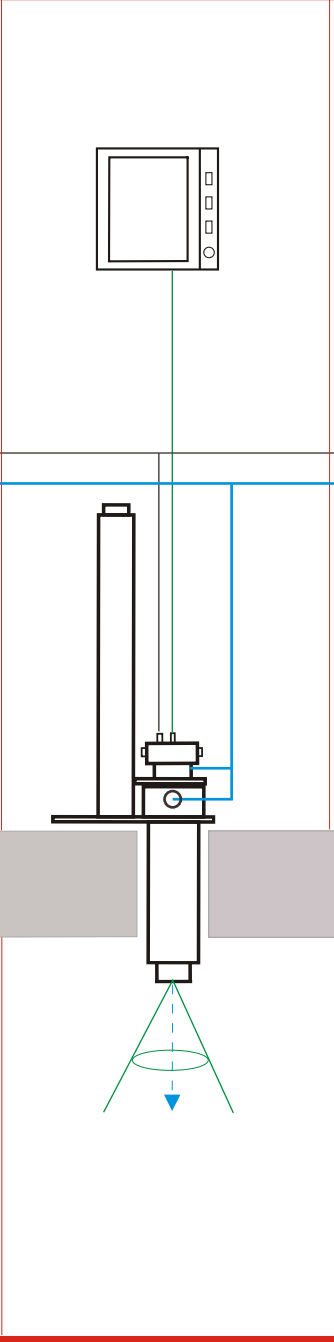
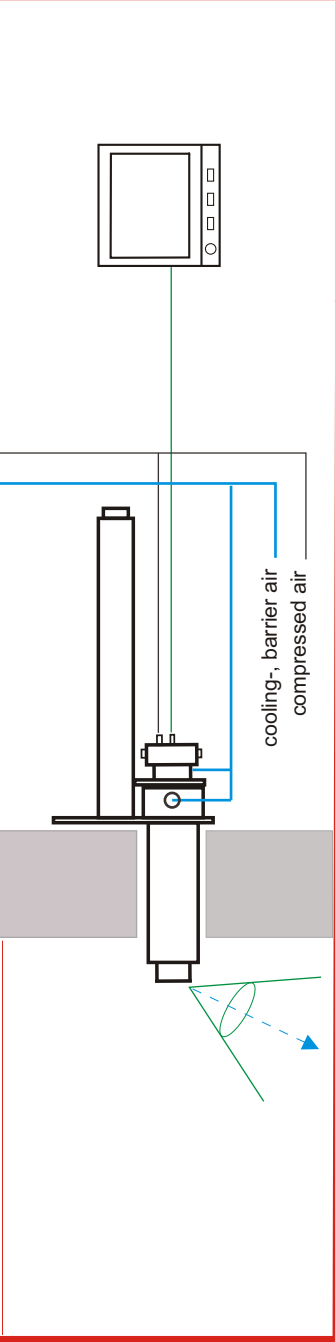
<p><u>Type: KG-LU-xx</u></p> <ul style="list-style-type: none"> - camera housing with air purged window - window made of temperature resistant temper-glass - color camera with e.g. zoom lens, special lens - temperature on tip -at widow- up-to e.g. 50 °C 	
<p><u>Type: SO-LU-G(A)-xx</u></p> <ul style="list-style-type: none"> - air cooled furnace probe camera with pin hole view - fix installation mode of probe camera - viewing aperture of probe appr. 2,5 mm diameter - color camera with special furnace lenses - various lenses with different angle of view - temperature inside furnace up-to appr. 600 °C 	
<p><u>Type: FKS-L-G-xx</u></p> <ul style="list-style-type: none"> - furnace camera system with air cooled probe camera, straight view - with retraction device for motion of the probe camera to furnace chamber - viewing aperture of probe appr. 2,5 mm diameter - color camera with special furnace lenses - various lenses with different angle of view available - temperature inside furnace up-to appr. 1400 °C 	
<p><u>Type:FKS-L-A-xx</u></p> <ul style="list-style-type: none"> - furnace camera system with water cooled probe camera with elbow view - with retraction device for motion of the probe camera to furnace chamber - viewing aperture of probe, appr. 2,5 mm diameter - color camera with special furnace lens - lens with 70° elbow view - temperature inside furnace up-to appr. 1000 °C 	

<p>Delta Kamerasysteme Frankfurt / Main</p>	<p>Furnace- and Combustion Surveillance</p>
<p>different methods, design of air cooled camera housings and system performance</p>	<p>ALG-L-01-E</p>

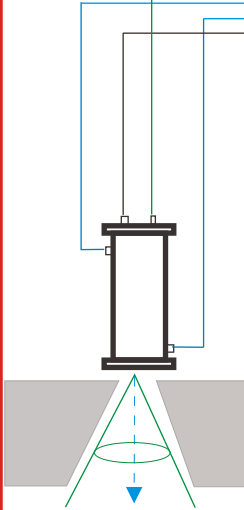
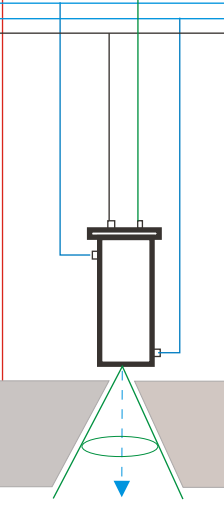
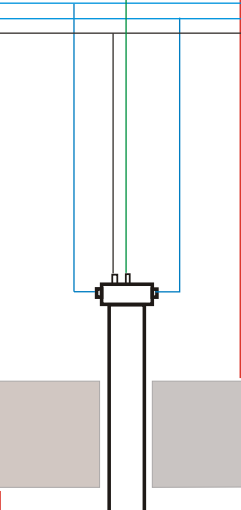
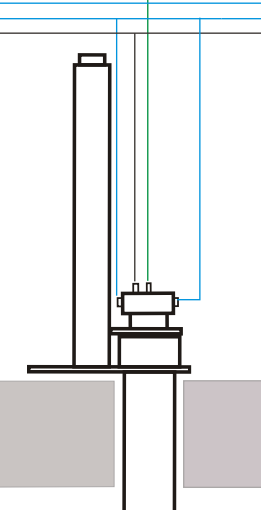
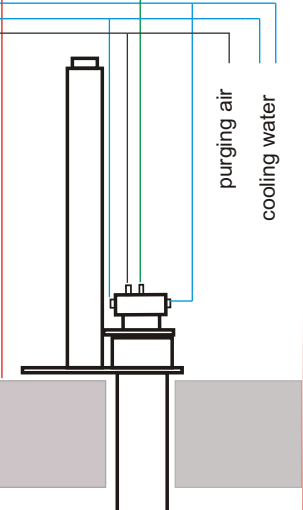
	<p><u>Type: KG-WS-xx</u></p> <ul style="list-style-type: none"> - water cooled camera housing with air purged window - window made of temperature resistant temper-glass - color camera with e.g. zoom lens, special lens - temperature on tip - at widow- up-to e.g. 200 °C
	<p><u>Type: KG-PH-xx</u></p> <ul style="list-style-type: none"> - water cooled camera housing with pin hole view - viewing aperure with diameter appr. 5 mm - color camera with pin hole lens (no optical zoom available) - temperature on tip - at viewing aperture- up-to appr. 600 °C
	<p><u>Type: Probe camera, fix installation</u></p> <ul style="list-style-type: none"> - water cooled furnace probe camera with pin hole view - fix installation mode of probe camera - viewing aperture of probe appr. 1,5 mm diameter - color camera with special furnace lenses - various lenses with different angle of view - temperature inside furnace up-to appr. 800 °C
	<p><u>Type: Camera system, straight view direction</u></p> <ul style="list-style-type: none"> - furnace camera system with water cooled probe camera, straight view - with retraction device for motion of the probe camera to furnace chamber - viewing aperure of probe appr. 1,5 mm diameter - color camera with special furnace lenses - various lenses with different angle of view available - temperature inside furnace up-to appr. 2000 °C
	<p><u>Type: Camera system, elbow vie direction</u></p> <ul style="list-style-type: none"> - furnace camera system with water cooled probe camera with elbow view - with retraction device for motion of the probe camera to furnace chamber - viewing aperure of probe, appr. 1,5 mm diameter - color camera with special furnace lens - lense with 70° elbow view - temperature inside furnace up-to appr. 2000 °C
<p>Furnace- and Combustion Surveillance</p>	
<p>ALG-W-01-E</p>	<p>Delta Kamerasysteme Frankfurt / Main</p>
<p>different methods, design of water cooled camera housings and system performance</p>	

to furnace

on site

control room

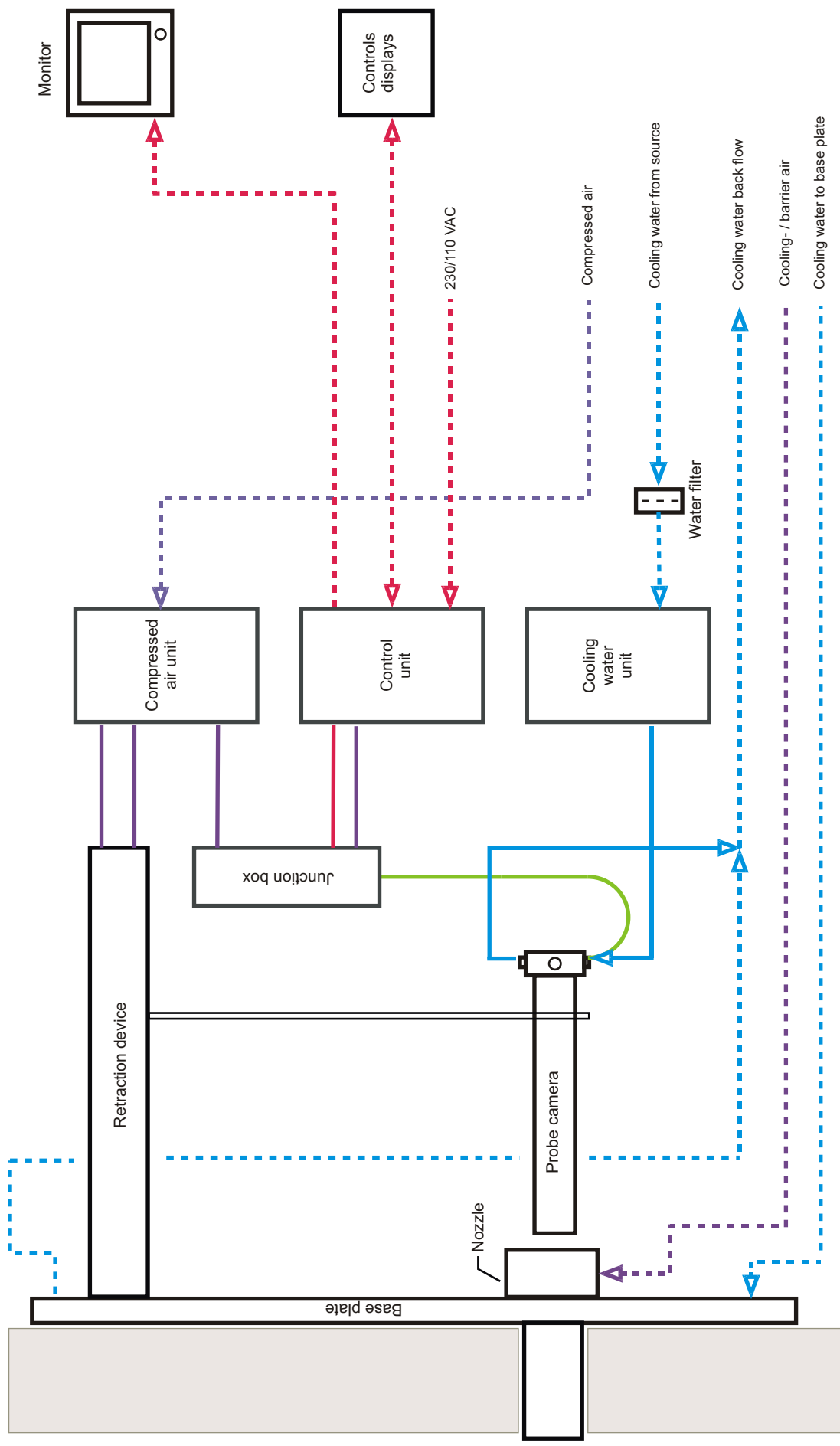

Furnace wall

Furnace camera system with retraction device

	system performance, components	Delta Kamerasysteme
SYS-RET-01-E	agents / system boundaries	Frankfurt / Main

--- supplied by customer

to furnace

on site

control room

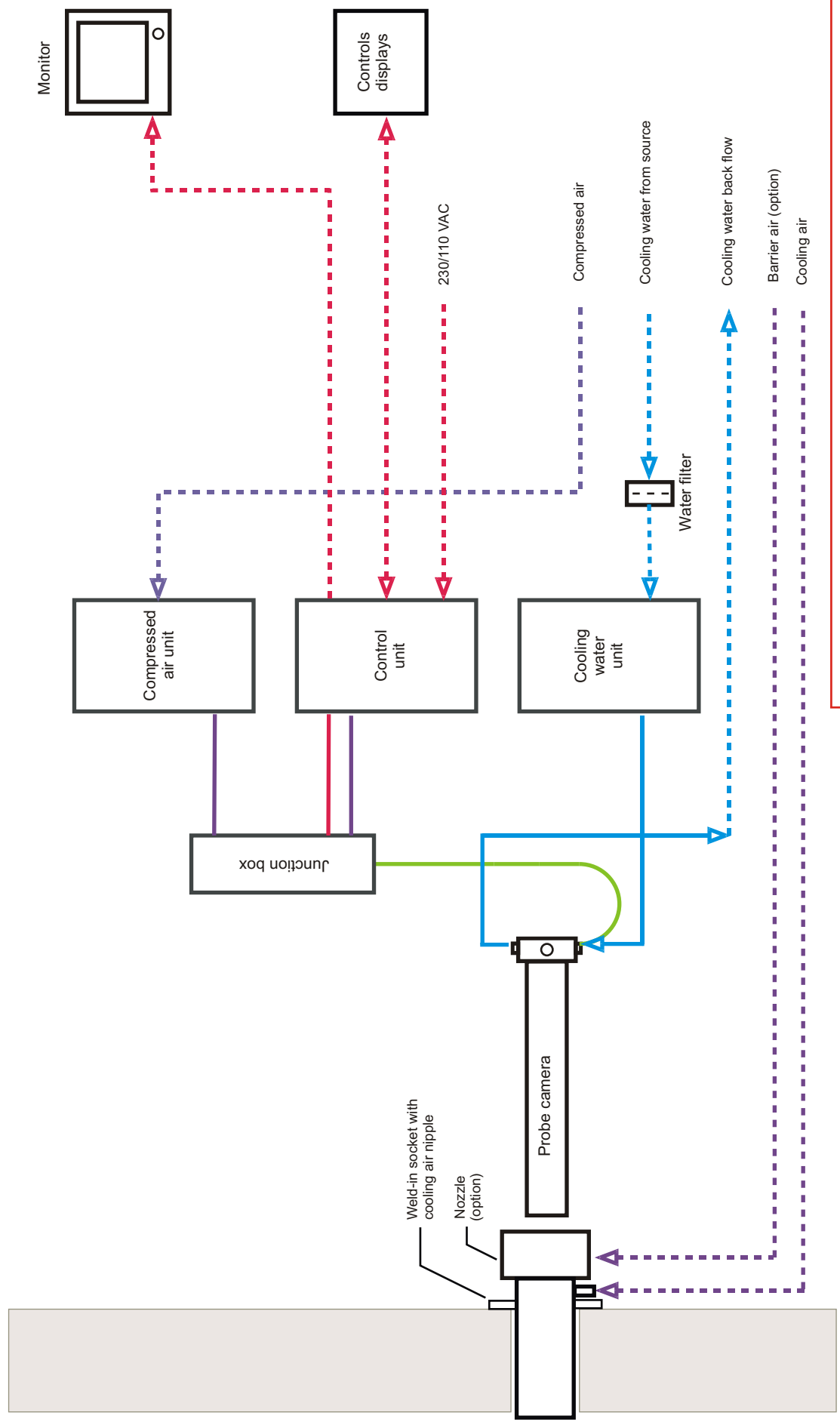

----- supplied by customer

Furnace camera system, fix installed

system performance, components

agents / system boundaries

Delta Kamerasysteme

Frankfurt / Main

SYS-FIX-01-E

on site

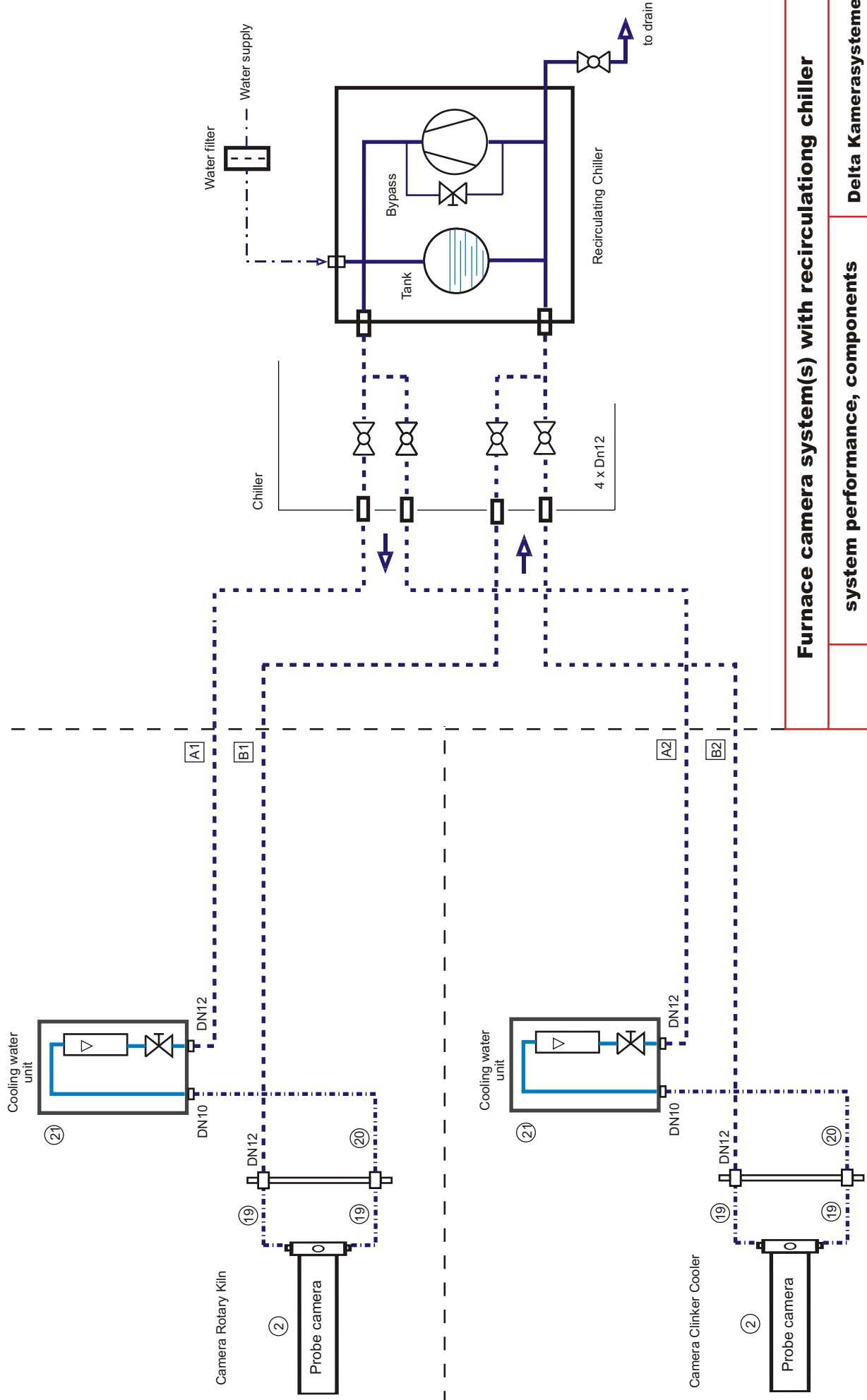

Furnace camera system(s) with recirculating chiller

system performance, components

sys-iks-01-E

Connections, piping

..... supplied by customer

Delta Kamerasysteme

Frankfurt / Main

viewing direction upwards

viewing downwards

viewing direction horizontal

Installation positions, probes with straight view

- horizontal (declination to probe tip appr. 3°)
- vertical position, view downwards
- up-tp appr. 45° declination upwards

note: with increasing decline in installation, length of probe has to be performed longer in case of constant furnace wall thickness.

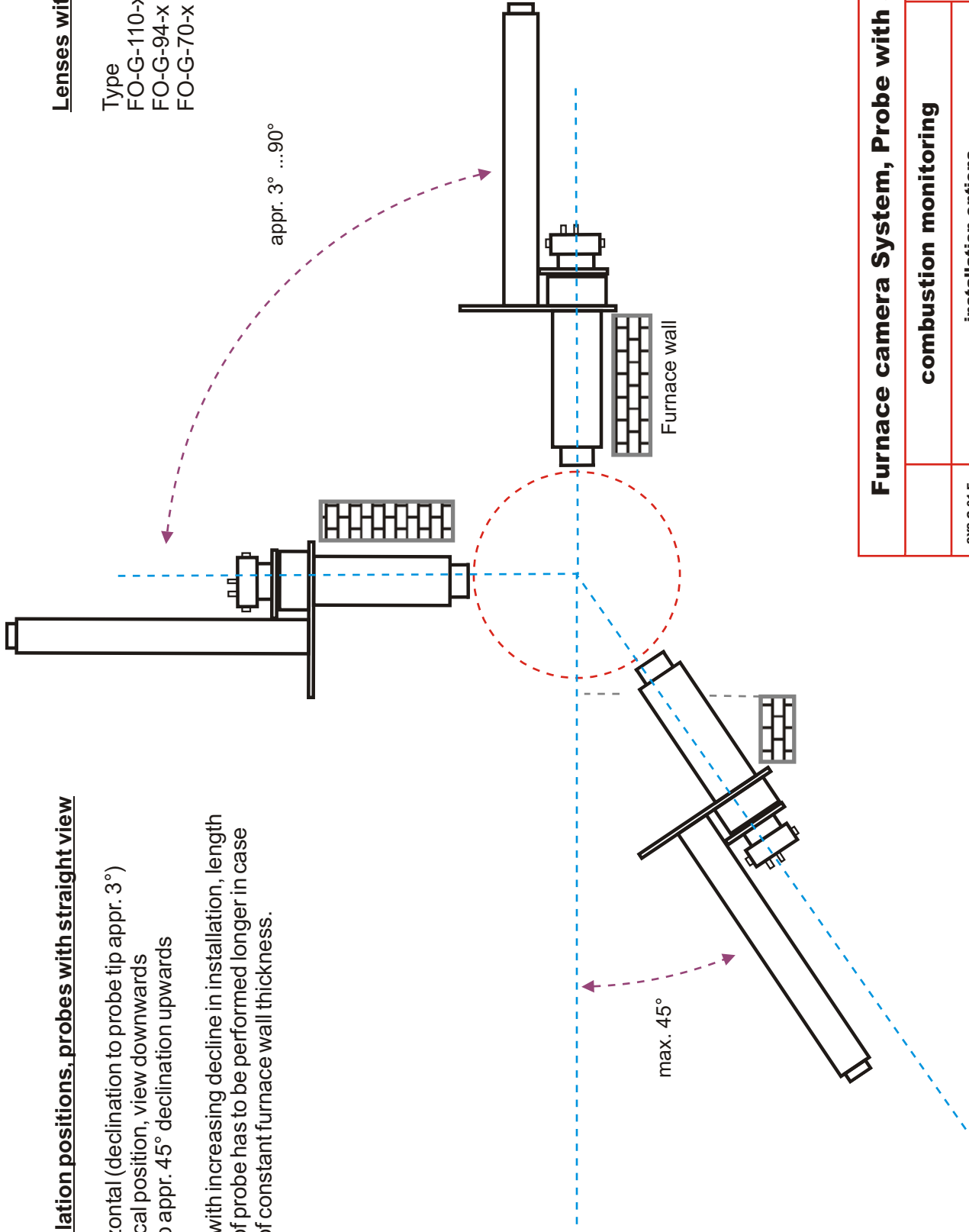

Furnace camera System, Probe with straight view

combustion monitoring

installation options

Delta Kamerasysteme

Frankfurt / Main

SYS-G-01-E

horizontal installation

vertical installation

horizontal installation

Installation position, probe with elbow view

- horizontal (3° declination to probe tip).
Possible viewing directions upwards, downwards left or right.
- Viewing direction and installation position have to be considered, when probe housing is manufactured.
- vertical, in case of difficult installation conditions
- aligned: due to elbow viewing direction, aligned installation position is not recommended.

lense with elbow view

Type angle of view
FO-A-70-x 70° x 56° x 42°

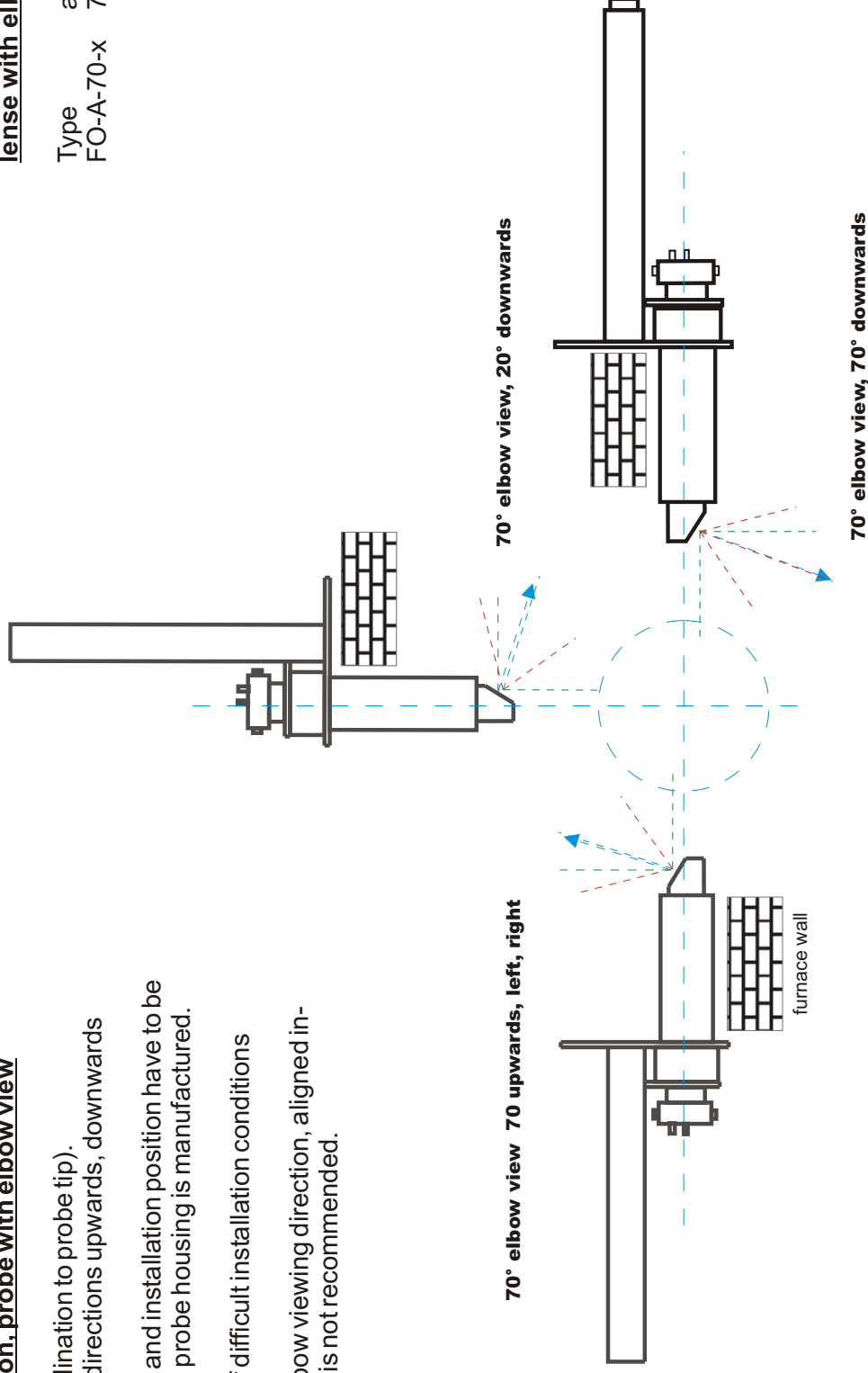

furnace camera system, probe with elbow view

combustion monitoring

installation options

SYS-A-01-E

Delta Kamerasysteme

Frankfurt / Main



Data sheets

Data sheets

- Furnace probe camera C1317F
- CCD color camera C1317F
- Furnace probe lenses
- Probe camera housing, water cooled
- Probe camera housing, air cooled
- Junction box
- Retraction device
- Accessories for fix installation of probe
 - Welding socket
 - Welding socket with cooling air supply
 - Transition piece
 - Mounting flange
 - Dummy flange
 - Air-barrier nozzle
 - Air-barrier valve
- Control unit
- Cooling water unit
- Compressed air unit
- System accessories
 - Tube and cable set
 - Reversible flow filter
 - Cooling air switch
 - Compressed air switch
 - Thermometer with T-piece



Furnace Probe Camera C1317F



Furnace probe camera CCBC1317F

Furnace probe camera consisting of CCD color camera C1317F, furnace probe lens and probe camera housing.

Probe housing

- Probe camera housing in 2 standard and long design
- Housing made of CrNi-steel or Titanium.
- Double walled housing for cooling water; with forced ventilation, temperature monitoring at the probe tip.
- Probe with straight viewing direction or 70° elbow view.
- Housing and viewing aperture air -purged for cooling purpose and keeping the viewing aperture clean.
- V-mounting flange for accurate centering of probe housing.

CCD-Camera

- High resolution color camera
- Interline transfer CCD image sensor with color raster filter
- Sensor size 1/3 inch.
- 625 lines, 50 fields/s according to CCIR (PAL)
- Without geometric distortions
- CCVS output $U_{pp} = 1\text{ V}$ into $75\ \Omega$
- resolution ≥ 450 TV lines, horizontal
- White balance automatic or manual
- Remote control parameterization possible via interface (TTL or RS485), thus enables full system integration
- Electronic zoom function (max 4 x)
- Electronic pan-and tilt function
- AGC adjustable from typical 0 dB to 24 dB (max 48 dB)
- Input voltage: 12V DC/ 24V AC

Lenses

- Furnace probe lens with viewing aperture 1,5 mm \varnothing
- Lenses with wide angle and wide depth of focus
- Lens with straight view, 70°, 94°, 110° diagonal view
- Lens with elbow view 70° and 70° diagonal view
- Auto-iris function, video controlled
- Camera adapter for 1/3", 1/2" and 2/3" image sensors
- With filter holder for 2 additional filters

Technical data

Camera

Type	CCD color camera
Temperature of use at tip of probe housing	$\leq 2000\ \text{°C}$
Degree of protection	IP 54 acc. To DIN 40050
Dimensions	as per data sheet probe housings
Connections	5 pole plug DC12C, CCVS signal

Cooling water

for probe camera housing

- Water	clean, filtered, chemically non-corros.
- Input overpressure	2 bar (max 4 bar)
- Inlet temperature	25 °C to 38 °C
- Outlet overpressure	0 bar, open to atmosphere max. 2 bar in closed circulation
- Outlet temperature	max. 40 °C
- Flow rate	2 to 20 l/min (20 l/min at ΔP of 4 bar; > 5 l/min with elbow viewing direction)

Volum of probe housing

appr. 2,5 dm³ in short version

Solids	< 10 mg/l
Carbonate hardness	< 1,8 mval/l (5° dH)
Non-carbonat hardness	< 1,8 mval/l (5° dH)
Total hardness	< 3,6 mval/l (10° dH)
pH value	6 to 7,5
Conductivity	< 0,5 mS/cm

Purging air

for viewing aperture of probe and front lens

Air condition	clean compressed air free of oil, water
Purity	99,999 % filtration referring to aerosoles of 0,01 μm diameter. Air supplied from compressed air unit.
Pressure	0,2 to 0,3 bar (max. 2,5 bar)
Temperature	< inlet temperature of cooling water or cold dried air with dew point < 0 °C
Consumption at 0,2 bar	appr. 2 m ³ /h



Furnace Probe Camera C1317F

Ordering data

Item	Order No.:
Furnace Probe Camera C1317F ¹⁾ CCD color camera with furnace probe lens And probe camera housing 450 TV-lines, 50 fields/s	2GF1181 - 6
Probe camera housing - Made of CrNi steel short design long design - Made of Titanium short design long design	 E G B D
Viewing direction ¹⁾ (probe camera housing) - Straight viewing direction - Straight viewing direction, upright format image - Elbow viewing direction 70° upwards upwards, upright format image downwards downwards, upright format image to the left to the left, upright format image to the right to the right, upright format image	 A 0 B 0 C 0 D 0 E 0 F 0 G 0 H 0 J 0 K 0
Furnace probe lens ²⁾ with furnace probe lens, lens with video-controlled auto iris incl. 2 cleat glass plates BK7, fitted - Lens with straight viewing direction: diagonal angle of view 70° diagonal angle of view 94° diagonal angle of view 110° - Lens with elbow viewing direction, diagonal angle of view 70° ²⁾	 1 2 3 4
Camera cable for camera CCFC1315 with camera connection plug, 2,8 m long, heat-resistant up to 180°C same as above but cable length 3,1 m	G23942-D0009-D020-1 G23942-D0009-D021-1

¹⁾ Elbow view is obtained, using an internal prism. Thus features a mirror image. On request, special CCD camera with electronic mirror image function may be supplied, which enable display of upright and true-sided video image.

²⁾ A straight viewing direction of the probe camera housing necessitates a straight viewing direction of the furnace lens and vice versa. The same applies to the elbowed viewing direction.



CCD Color Camera C1317F



CCD color camera C1317F

- Color camera with interline transfer CCD as image sensor 752 (H) x 582 (V) pixels
- Sensor size corresponding to a 1/3" image sensor
- 625 lines, 50 fields/s according to CCIR (PAL)
- Also available for NTSC standard
- No geometric distortions
- > 0,2 lx sensitivity image for good picture quality
- Sensitivity: appr. 9000 : 1 (ES 600 : 1, AGC 15 : 1)
- Electronical zoom (max. factor 4)
- Shutter speed 1/50 s.. flickerless ... 1/30000 s
- Automatic iris control signal, video signal controlled
- Gamma, typicly 0,45
- Immediately operable
- C-Mount thread for furnace lens
- RS232/RS485 for parameter setting via computer interface
- 12 VDC / 24VAC power supply
- Suitable for installation to probe housing 2GF1700-8-xx

Technical data

Standard	CCIR, 50 fields/s (PAL) alternatively EEIR, 60 fields (NTSC)
Image sensor	interline transfer, 1/3"
Resolution	> 450 lines horizontal
Sensitivity	
Object illumination	
70° angle of view	≥ 50 dc/m ² for good picture quality ≥ 10 dc/m ² for sufficient picture quality
94° angle of view	≥ 20 dc/m ² for good picture quality ≥ 05 dc/m ² for sufficient picture quality
110° angle of view	≥ 12 dc/m ² for good picture quality ≥ 02 dc/m ² for sufficient picture quality
Color temperature	range 3200 K to 9000 K
White balance	automatic / manual
Video amplifier	
- output signal	U _{pp} = 1 V into 75 Ω
- signal/noise rat.	≥ 46 dB, weighted, AGC off
Deflection	
- picture geometry	disortion-free
- synchronization	internal or external via color composite signal or H and V signal
Power supply	12 VDC or 24 VAC
max temperature	0°C to 45 °C, for compliance with the technical data



CCD Color Camera C1317F

Ordering data

Item	Order no.
CCD Color Camera C1317F 1)	2GF1181 - 5 A
CCD color camera for installation in probe camera housing 2GF1700-8-xxx	
Design for short probe camera housing with viewing direction:	
- upwards or downwards	A 1 1
- straight, upwards or downwards (upright format image)	A 1 2
- to the left or right (upright formate image)	A 1 3
- straight left or right	A 1 4
Design for long camera housing with viewing direction:	
- upwards or downwards	B 1 1
- straight, upwards or downwards (upright format image)	B 1 2
- to the left or right (upright formate image)	B 1 3
- straight, left or right	B 1 4
Camera cable for camera CCFC1315	G23942-D0009-D020-1
with camera connection plug, cable 2,8 m long cable heat resistant up to 180 °C	
same as above, but cable 3,1 m long	G23942-D0009-D021-1

- 1) Elbow view is obtained, using an internal prism. Thus features a mirror image. On request, special CCD camera with electronic mirror image function may be supplied, which enable display of upright and true-sided video image.



Furnace Probe Lenses



1 = straight view, 70°
 2 = straight view, 94°
 3 = straight view, 110°
 4 = elbow view, 70°

Furnace probe lenses

- Probe lenses with various angles of view, straight viewing direction or 70° elbowed viewing direction via prism.
- Aperture control manually via remote control or automatically by means of video signal control, with ND filter.
- Wide angle lens with fixed focal length, high resolution and wide depth of focus.
- To protect the lens from thermal radiation, the viewing in front of the lens passes through a opening of Ø 1,5 mm, only.
- Lens with filter holder for two filter units.
- Filters for matching of image to required spectral range and contrast of video signal.
- Lense with camera adapters for 1/3", 1/2" and 2/3" image sensor size.

Filters

Glass thickness	2 mm
Transmission to light ¹⁾	
- Blue filter BG12 (dark)	72 % at 400 nm
slight permeability to red	< 1 % at 500 nm
- Blue filter BG23 (medium)	83 % at 450 nm
average permeability to red	< 1 % at 600 nm
- Green filter VG9	54 % at 520 nm
slight permeability to read	< 1 % at 440 nm > 640 nm
- Orange filter OG530	90 % at 600 nm
	< 1 % at 520 nm
- Neutral grey filter NG4	30 %
- Clear glass plate BK7	95 %

Technical data

Image areas	for 1/3", 1/2" or 2/3" format
Ratio of lens	1 : 5,6 (70° lens) 1 : 3,5 (94° lens) 1 : 2,8 (110° lens)
Depth of focus	1 m to ∞
Mounting thread	C-mount
Viewing pupil	appr: 1,5 mm diameter
Degree of protection	IP 60 to DIN 40050
Dimensions	max. diameter 63 mm appr. length: 315 mm (as per lens)
Weight	appr. 1,5 kg

Performance

Viewing direction	Angle of view		
	diagonal	horizontal	vertical
straight	70°	58°	45°
straight	94°	81°	65°
straight	110°	97°	81°
70° elbow	70°	58°	45°

¹⁾ Optical filters, color glass filters, are classified by means of its spectral transmission capability.



Furnace Probe Lenses

Ordering data

Item	Order No.
Furnace Probe lenses	2GF1670 - 8 <input type="checkbox"/> <input type="checkbox"/>
With video-signal controlled auto iris function incl. 2 pc. clear glass plates BK7, fitted suitable for camera with 1/3", 1/2" or 2/3" image sensor	
camera adapter for 2/3" image sensor	C
camera adapter for 1/2" image sensor	D
camera adapter for 1/3" image sensor	E
Straight viewing direction	
- 70° diagonal view (G70A)	A
- 94° diagonal view (G94A)	B
- 110° diagonal view (110 A)	C
Elbow viewing direction 70°	
- 70° diagonal view (A 70 A)	D
Filter plates	
- clear glass BK7	2GF1693-8BA
- neutral grey filter NG4	2GF1693-8BB
- blue filter BG12, dark	2GF1693-8BC
- blue filter BG23, medium	2GF1693-8BD
- green filter VG9	2GF1693-8BE
- orange filter OG530	2GF1693-8BF



Probe Camera Housing, Water cooled

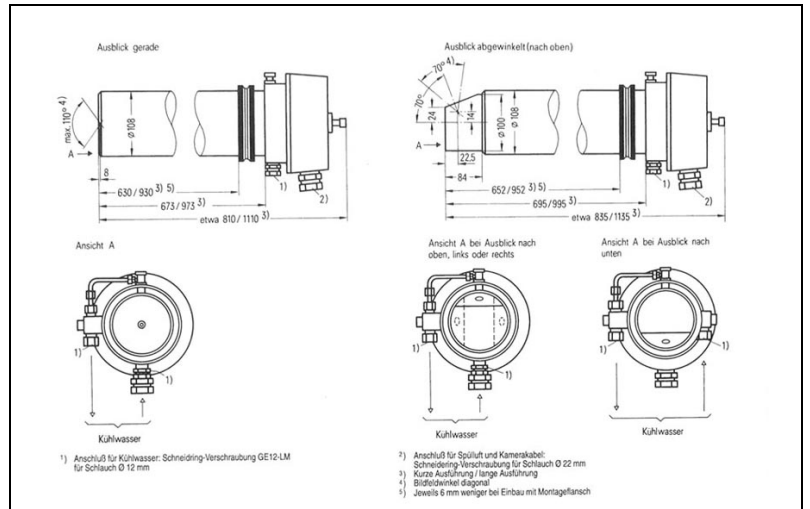

Ordering data

Item	Order no.
Probe camera housing, water cooled	2GF1700 - 8 <input type="checkbox"/> <input type="checkbox"/>
With V-flange, flange distance from tip of camera housing: 630 mm oder 930 mm (straight viewing direction) or 625 mm oder 925 mm (elbowed viewing direction)	
Design	
- Made of CrNi steel 1.4571	
Short design	M
Long design	N
- Made of Titan	
Short design	D
Long design	H
Viewing direction	
- straight	A
- upwards	B
- downwards	C
- to the left	D
- to the right	E



Probe Camera Housing, Air cooled

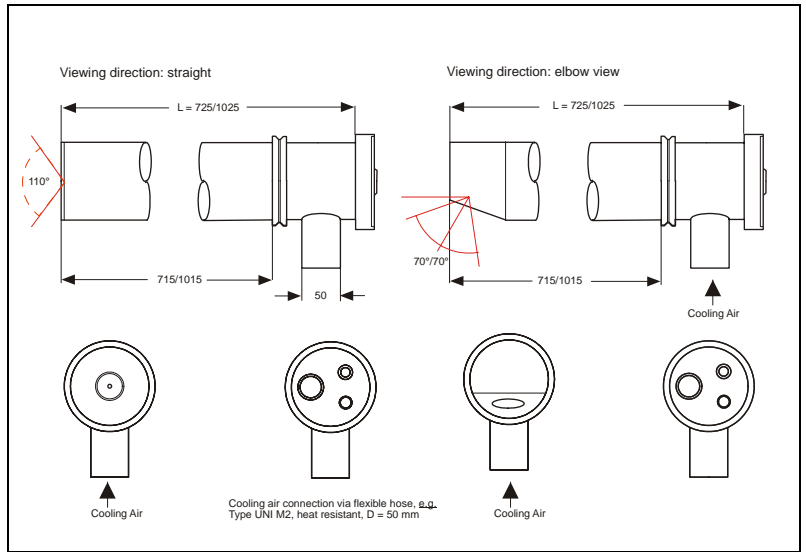

Ordering data

Item	Order no.
Probe camera housing, air cooled	2DK1000 - 1 <input type="checkbox"/> <input type="checkbox"/>
With adjustable V-flange, flange distance from tip of camera housing 715 mm or 1015 mm (straight viewing direction) or 715 mm or 1015 mm (elbowed viewing direction)	
Design	
- Made of CrNi steel 1.4571	
Short design	A
Long design	B
Viewing direction	
- straight	A
- upwards	B
- downwards	C
- to the left	D
- to the right	E



Accessories for fix installation of probe camera

Welding socket

Welding socket for rigid installation of a furnace probe camera if the design of the furnace allows manual retraction of the camera in case of failures. It is suitable between any partial vacuum and the overpressure up to 30 mbar in the furnace (only with air nozzle) as well as furnace temperatures up to 300 °C respectively 800 °C with the air barrier nozzle. The socket is welded into the boiler- or into the furnace wall and surrounded by walls.

The probe camera is fastened with screws. Without cooling air supply it is suitable for furnace temperatures up to 300 °C under the condition of non-corrosive furnace atmospheres. Welding sockets with 4 different lengths are available for different wall thickness.

Ordering data

Item	Order no.:	Weight (kg)
Welding socket (St 35)		
furnace temperature \leq 300 °C		
- 300 mm long	2GF1701-8AA	11,3
- 400 mm long	2GF1701-8AB	14,5
- 500 mm long	2GF1701-8AC	17,7
- 600 mm long	2GF1700-8AD	20,9

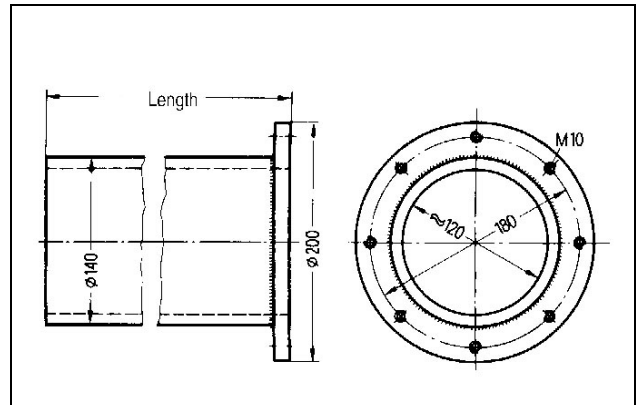

Welding socket with cooling air supply

Technical data

Cooling air	necessary in case furnace is heated \geq 300 °C
Pressure	10 mbar to 200 mbar at least double the furnace pressure
Consumption	0,2 m ³ /min to 1,6 m ³ /min
Temperature	30 °C to 50 °C
Connection	male thread R1"

Ordering data

Item	Order no.:	Weight (kg)
Welding socket (St 35)		
furnace temperature \leq 800 °C		
- 300 mm long	2GF1701-8AE	11,8
- 400 mm long	2GF1701-8AF	15,0
- 500 mm long	2GF1701-8AG	18,2
- 600 mm long	2GF1700-8AH	21,4

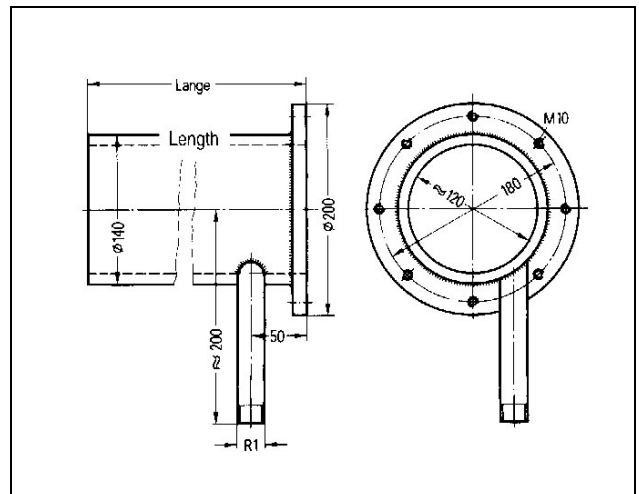

Transition pipe

Transition piece for of probe camera to furnace with lower wall thickness.

Ordering data

Item	Order no.:	Weight (kg)
Transition pipe (St 35)		
with fastening screws		
- 200 mm long	2GF1701-8BC	11,8
- 300 mm long	2GF1701-8BD	15,0

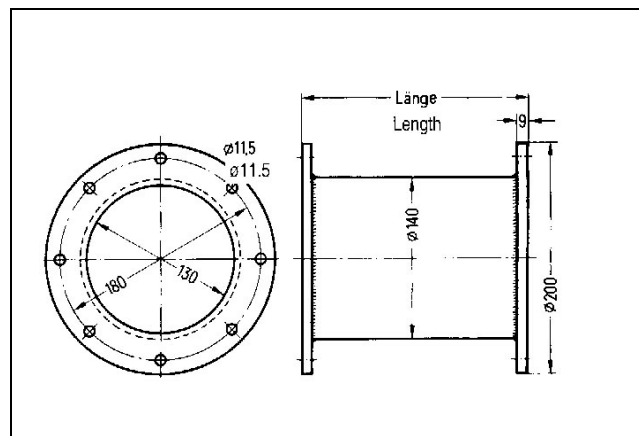



Accessories for fix installation of probe camera

Mounting flange

Mounting flange as a adapter ring for fastening the probe camera housing (with V-flange) to the welding socket; the mounting depth of the probe camera housing is reduced by 6 mm.

Ordering data

Item	Order no.:	Weight (kg)
Mounting flange (St 35) with installation material	2GF1701-8EA	2,5

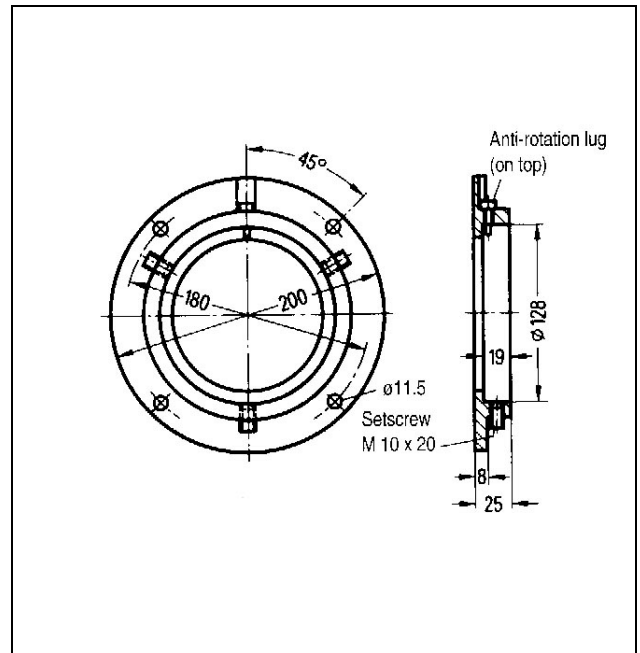
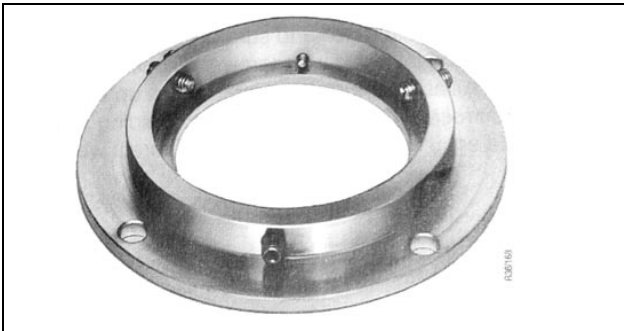

Dummy flange

Dummy flange for closing the furnace gap after removing the Probe camera

Ordering data

Item	Order no.:	Weight (kg)
Dummy flange (St 35) with installation material	2GF1701-8CA	2,0

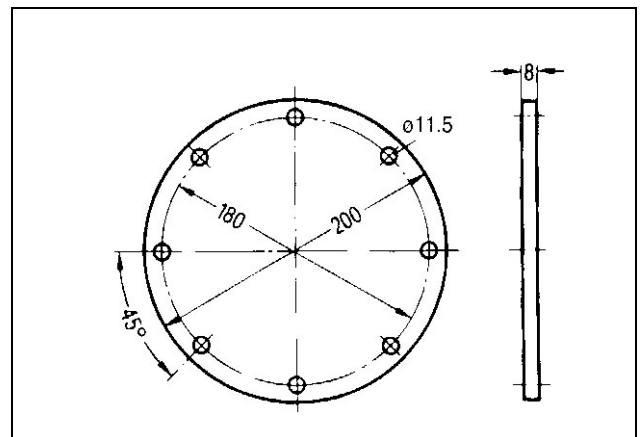

Barrier-air nozzle

The barrier-air nozzle is necessary in the case of overpressure furnaces. It is installed between the flange of the welding socket and the mounting flange. The compressed air from this annular nozzle stops flames from bursting through during installation and removal of the probe camera.

The nozzle is designed for a max. furnace pressure of 30 mbar. Pressure of compressed air 1 bar to 7 bar, depending of furnace pressure. Consumption 2 m³/min to 9 m³/min. Connection via R1" female thread.

Ordering data

Item	Order no.:	Weight (kg)
Barrier-air nozzle (St 35) with installation material	2GF1701-8DA	2,0

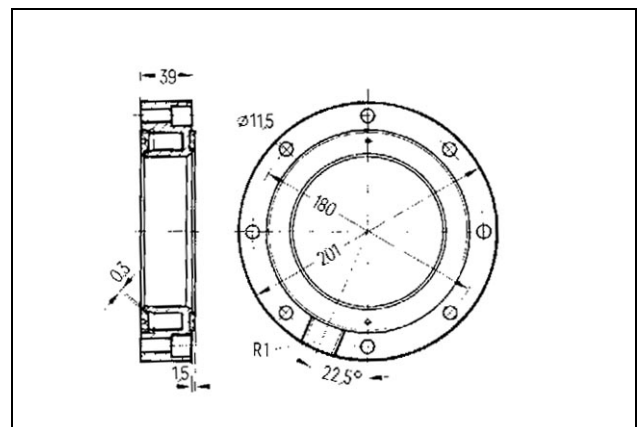



Accessories for fix installation of probe camera

Barrier-air valve

Barrier-air valve for regulating the supply of the barrier-air nozzle; manually controlled valve with manometer, scaled 1 – 6 bar.

Ordering data

Item	Order no.:	Weight (kg)
Barrier-air valve	2GF1703-8JA	2,0

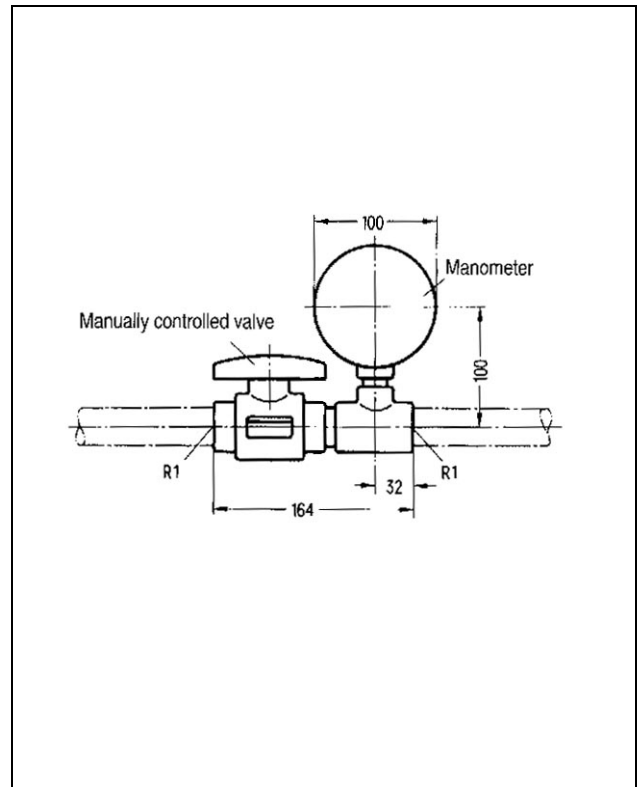

Tube and cable set

Tube and cable set for connection of the probe camera to the junction box and the cooling water supply.

Ordering data

Item	Order no.:	Weight (kg)
Tube and cable set for probe camera housing	2GF1810-8FF	2,0

Technical data

Tube and cable set D22	for furnace probe cameras B1317F / C1317F
Purging air tube	2 m long, 22 mm diameter
2 water tubes	2 m long, 12 mm diameter connect. For ferrule screw glands
thermal control cable	2,8 m long, 2 signal conductors



Junction box

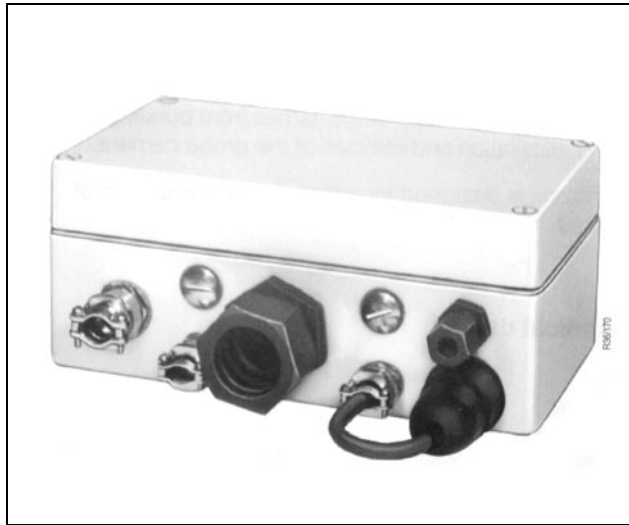

Junction box

- Junction box for connecting the furnace probe cameras B1315F and C1315F to the subsequent units via a tubing and cable arrangement
- Junction box with pressure monitor for the purging air pressure; box hermetically sealed lid and terminal strip (12-pin)

For the cameras B1315F and C1315F, the coaxial cable of the video signal, the thermal cable, the power supply and the purging air supply are connected to the junction box.

The cables are shielded properly up to an ambient temperature of 70 °C at the junction box itself. For temperatures between 70°C to 120 °C, the cables from the junction box are led away from the hot ambient in an additional air-cooled protection tube (hose) to a second casing. This case is then supplied with purging air; the pressure shall be increased from appr. 0,2 bar to appr. 0,3 to 0,5 bar overpressure.

The casing is performed with a looping-through facility for the cable, which means the cables are not interrupted.

Technical data

Junction box 9/12	for furnace probe cameras
Degree of protection	IP 65 to DIN 40050
Terminals for cable	12
Screwed glands	5 x M16 (cable diam. 6 to 9 mm)
Purging air inlet	Screwed gland for 8 mm tube
Purging air outlet	Ferrule screwed gland GE22-LM For tube with 22 mm diameter
Additional tube	28 mm diam.
Dimensions	220 x 90 x 120 mm without fittings
Attachment	4 tapped holes for M6 (204 x 84 mm)

Ordering data

Item

Order no.:

Junction box 9/12

- for ≤ 70 °C ambient temperature
- for ≥ 70 °C ≤ 120 °C ambient temperature with additional casing and 4 m hose (other length on request)

2GF1801 -

8	E					
		A				
		C				

 -

--



Retraction Device

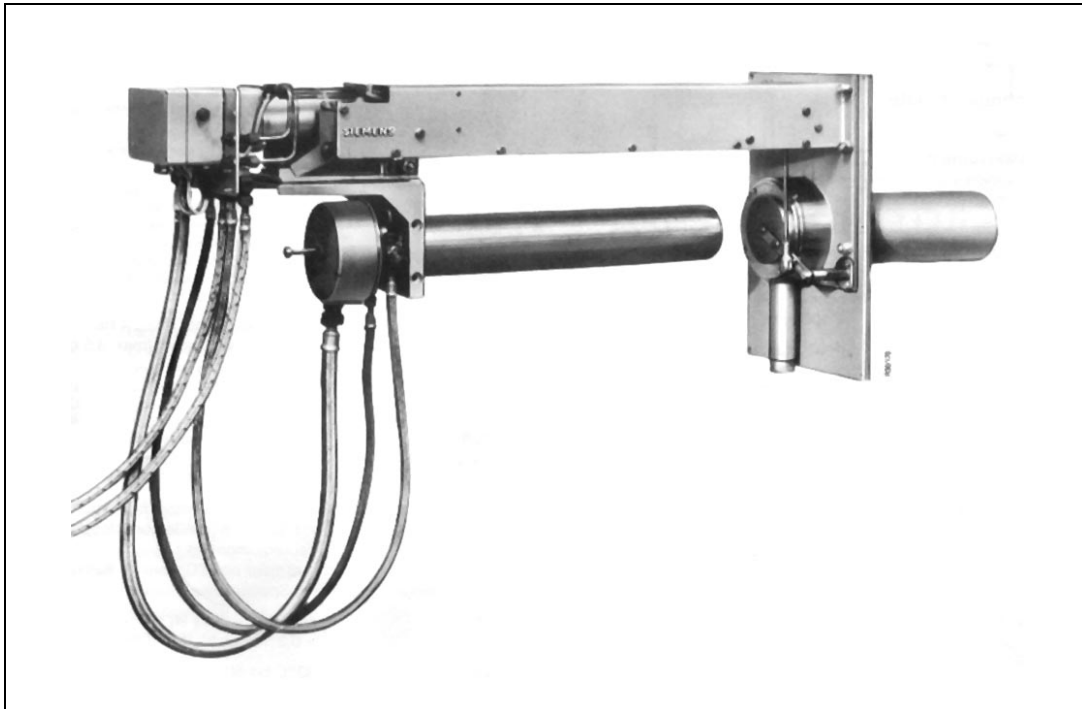

Retraction device

- Electro-pneumatically controlled retraction device for fully automatic retraction of a furnace probe camera out of the furnace in the case of failure of the cooling water supply, compressed air or mains supply. Damage to the camera or lens is thus prevented.
- Remote-controlled retraction is possible from the control room. Manual insertion and retraction is possible with a separate control unit 2GF1801-8AB.
- The device is driven with compressed air via solenoid valves in a separate compressed air unit.
- Designed for furnace pressures up to 3 mbar overpressure (with or without air nozzle for damming up the flue gases and prolonging the hold-up time of the probe camera housing in the furnace with or without shutter), or for furnace overpressure up to 100 mbar with lock chamber, shutter for furnace and air nozzle.
- Stroke length 750 or 1050 mm; automatic shutter locking when camera is retracted.
- Mounting position: viewing angle up to 90° downwards (above 3° with automatic insertion stop) or up to 45° upwards.
- Base plate for mounting on furnace wall, with or without water cooling; retraction device is mounted onto base plate using screws.
- Exact centering and securing of probe camera without additional adjustment.

- Minimum space and servicing requirements due to a special stroke cylinder with permanent lubrication for ambient temperatures up to 80 °C or up to 120 °C (e.g. for use on glass smelting furnaces).
- Swing-out probe camera, degree of protection IP 03, dust- insensitive.
- Connections for working air (insertion and retraction), cooling air, cooling water and electric connections to the probe camera.
- The conditions for installation in glass troughs have been considered.
- Junction box with pressure monitor for purging air pressure, air-cooled set of tubes and cables

Other features

- Each one of the 6 conditions mentioned below will effect automatic retraction of the probe camera:
 1. Exceeding of the cooling water temperature (e.g. 40 °C) set on the thermostat in the probe camera housing.
 2. Drop of the air pressure below the value (e.g. 4 bar) set on the compressed air unit.
 3. Drop of the purging air pressure below the value (e.g. 0.2 bar) set on the compressed air unit.
 4. Power supply failure.
 5. Interruption of a control line for air, water or temperature monitoring.
 6. Retraction command from the control room or the control unit.



Retraction Device

- The insertion or retraction process is initiated either automatically or manually via a control unit with a compressed air unit. The retraction process can be initiated directly from the control room with an additional key.
- With a 750 mm stroke the overall length from the base plate is only 1.3 m including the junction box.
- Oil in the compressed air is unnecessary due to special permanent lubrication.
- The insertion depth (length of the probe camera housing from the base plate) of the short probe is 528 mm with straight viewing and 550 mm with elbowed viewing. The insertion depth is extended by 86 mm without an air nozzle.
- Swivelling mechanism of the retracted probe camera housing: After unscrewing 2 hexagon nuts, the probe camera housing can be swivelled to the right or to the left by max. 90° for servicing or for the installation or removal of the camera. No additional space beyond the original length is required for the installation.
- The permissible ambient temperature for the stroke cylinder is either up to 80 °C or up to 120 °C with special gaskets. For ambient temperatures over 70 °C an additional air-cooled protection tube (up to 10 m long) with a casing is available in addition to a junction box with a set of tubes and cables.
- A switching-off facility for the purging air supply (with retracted camera) via a limit switch, combined with an additional purging air valve in the compressed air unit 2GF1703-... is also available.
- The version without a lock chamber contains a shutter of heat resisting steel which is operated mechanically with levers by the stroke movement of the probe camera and closes the furnace gap with the probe camera extracted. This mechanism is insensitive to dust and sediments from the furnace. The shutter is pneumatically controlled via a cylinder in the version with a lock chamber: this version is always fitted with an air nozzle.
- The air nozzle is required for cooling the shutter, for ventilating the probe camera housing (prolonging of hold-up time) and for damming up the flue gas with a slight overpressure and/or corrosive flue gas or furnace wall sediments. The air nozzle operates with a minimum overpressure (approx. double the furnace overpressure), so that compressed air is not required.
- The purging air pressure is monitored in an air-tight junction box with connection facilities at the bottom and with push buttons and terminal board (12-pin) so that the probe camera can be retracted in order to protect the camera lens if the probe camera lid has been fastened incorrectly or loosely for example
- Different base plates made of St37 with a connection sleeve (internal diam. 120 mm) are available; they are mounted or welded onto the outer wall of the boiler or furnace - initially separately from the retraction device. Base plates without water cooling (up to 60 °C wall temperature) or with water cooling and connection sleeve made of St35 or of a heat-resisting steel alloy are available in 2 different lengths or any length on request.
- The permissible installation inclination with straight viewing is up to 90° downwards or up to 45° upwards. If a 3° inclination downwards is exceeded, the pneumatically operated insertion stop is required to avoid insertion in case of air failure.

Technical data

Retraction device

Installation positions, referring to horizontal cylinder axis	+3° to +45° or -3° to -90°
Material of base plate/ connection sleeve	St37/St35 or X15CrNiSi2520 (heat-resistant steel)
Version for furnace overpressure	< 3 mbar (partial vacuum design) or < 100 mbar (over pressure design)
Degree of protection (DIN 40050)	IP03, dust-intensive
Temperature of use	
- Partial vacuum design	-20 °C to + 80 °C or -20 °C to + 120 °C
- Over pressure design	-20 °C to + 80 °C
Probe speed	appr. 0,1 m/s
Time for one stroke (insertion / retraction)	appr. 10 s to 15 s with short camera housing
Weight (2GF1712-...)	appr. 90 kg
Working air (compressed air from air unit 2GF1703-...)	dry, free of oil and dust, filtered 5 µm filter

Pressure	4 bar to 8 bar angle of camera installation 3° to 15° 6 bar to 8 bar angle of camera installation: > 15°
Length of the cable to the compressed air unit	max. 10 m
Cooling water for version with water-cooled base plate	
Pressure	
- Inlet	0,3 bar to 0,5 bar (max. 4 bar)
- Outlet	0 bar, open outlet (max. 3,5 bar)
Consumption	up to 10 l/min
Outlet water temperature	< 50 °C
Cooling air For version with air nozzle and lock chamber	
Pressure	10 mbar to 200 mbar for version with lock chamber (at least double furnace pressure) 100 mbar to 800 mbar for version with air nozzle
Consumption	appr. 112 m ³ /min to 120 m ³ /h = 0,2 m ³ /min to 2,0 m ³ /min
Temperature	30 °C to 50 °C



Retraction Device

Ordering data

Item	Order no.						
Retraction device For furnace pressure < 3 mbar overpressure, (> 0 mbar overpressure: air nozzle required)	2GF1712 - <input type="checkbox"/> <input type="checkbox"/> <input type="checkbox"/> <input type="checkbox"/> <input type="checkbox"/> <input type="checkbox"/> - <input type="checkbox"/> <input type="checkbox"/>						
Chassis							
- With 750 mm stroke							
< 80 °C ambient temperature	1						
< 120 °C ambient temperature	2						
- With 1050 mm stroke (long probe camera housing necessary)							
< 80 °C ambient temperature	3						
< 120 °C Umgebungstemperatur	4						
Base plate							
- Without base plate		A					
- With base plate (furnace wall temperature < 60 °C)							
St35-sleeve, 520 mm long (with 750 mm stroke)		B					
St35-sleeve, 820 mm long (with 1050 mm stroke)		C					
- With water-cooled base plate							
St35-sleeve 520 mm long (with 750 mm stroke)		E					
St35-sleeve 820 mm long (with 1050 mm stroke)		F					
X15-sleeve 520 mm long (with 750 mm stroke)		H					
X15-sleeve 820 mm long (with 1050 mm stroke)		J					
- With base plate in spezial design ¹⁾		Z					
Junction box							
- without junction box		A					
- with junction box 9/12							
for ≤ 70 °C ambient temperature		B					
For > 70 °C ambient temperature with 4 m protection tube		D					
and additional casing							
- With junction box 9/12 for > 70 °C ambient temperature							
4 to 10 m protection tube and additional casing on request							
Furnace locking							
- Without shutter			1				
With air nozzle			0				
With air nozzle for St35 or X15 sleeve			1				
- With shutter				2			
without air nozzle				3			
With air nozzle for St35 or X15 sleeve				4			
With air nozzle for ceramic sleeve							
Insertion stop							
- Without insertion stop				0			
- With insertion stop				1			
(necessary from 3° inclination downwards)							
Limit switch for purging air stop							
- Without limit switch				-	0		
- With limit switch				-	1		
(max. 80 °C amb. Temperature, purging valve							
in compressed air unit 2GD1703-... necessary)							
Tubes and cables							
- Without tubes and cables				-		A	
- With tube- and cable set D22 ²⁾				-		F	
(without installation tube set)				-			
- With installation tube set ³⁾				-		G	

¹⁾ On request (for example ceramic sleeve)

²⁾ Tube and cable set D22 consisting of: 1 purging air tube D22 (M28), length 2 m, 2 cooling water tubes (12 mm diam, / 2m)
1 signal cable, thermo cable for temperature monitoring inside probe, length: 2,8 m.

³⁾ Installation tube set 2GF1801-8FC, consisting of : 3 air tubes (8 mm diam./2 m, for working air 'insertion', working air 'retraction' and purging air inlet), 2 cooling water tubes (12 mm diam./2 m, cooling water inlet and outlet for probe camera housing) and also two screwed glands, R 1/2".

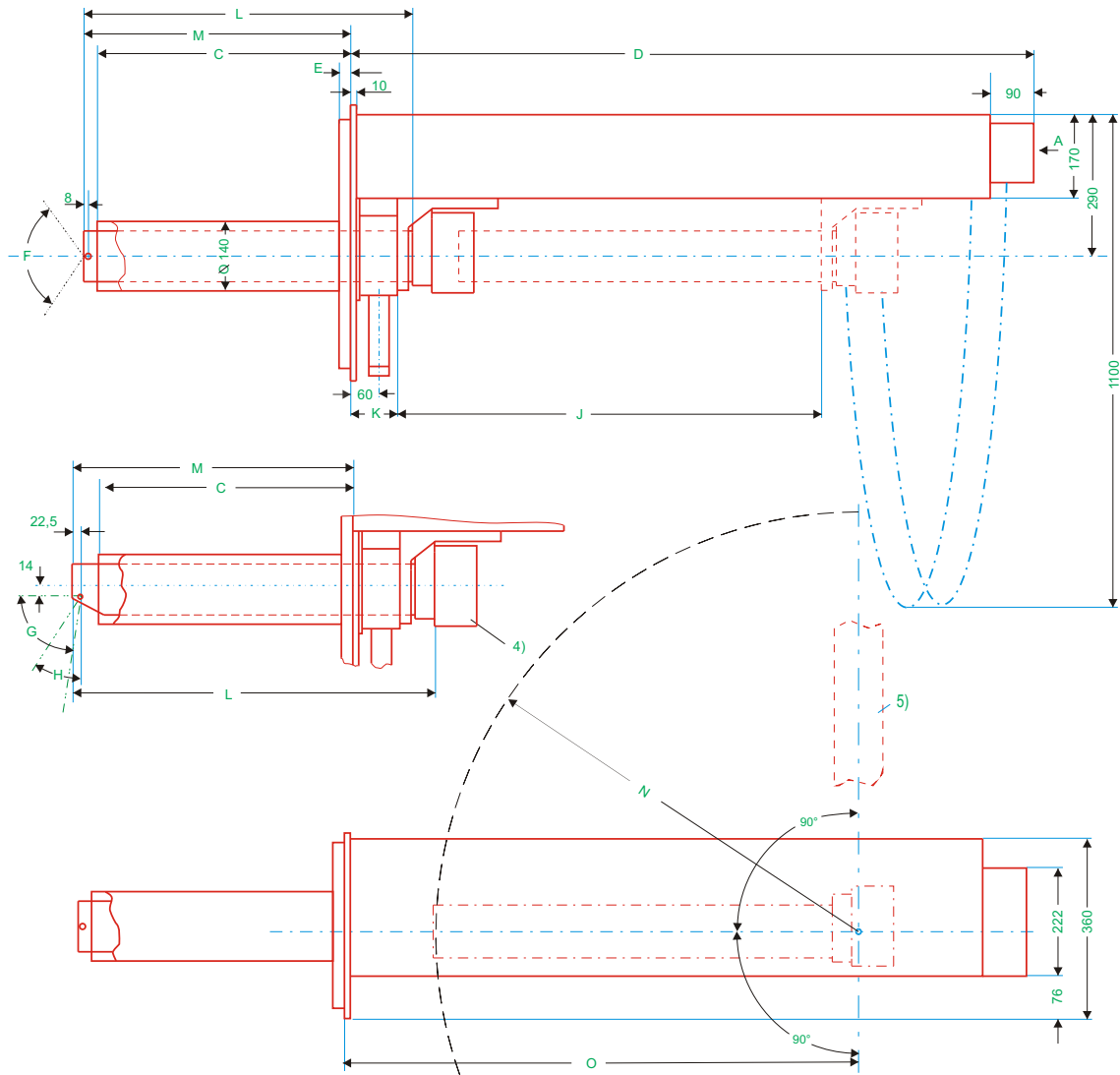

Dimensions (mm) or angle	Explanation	Short probe camera housing		Long probe camera housing	
		viewing direction straight	elbow	viewing direction straight	elbow
C	Length of sleeve	< 520	< 520	< 820	< 820
D	Total length from base plate	1300	1300	1600	1600
E	With water cooled base plate	23	23	23	23
F	Diagonal angle of view	< 110°	-	< 110°	-
G	Viewing direction angle	-	70°	-	70°
H	Vertical angle of view (horizontal = 58°)	-	45°	-	45°
J	Stroke length	750	750	1050	1050
K	With air nozzle (otherwise: 10)	96	96	96	96
L	Length from stop	673	695	973	995
M	Insertion depth from base plate	528	550	828	850
N	Pivoting radius	700	725	1000	1025
O	-	952	952	1252	1252
P	Viewing direction straight, upwards, right or left	167	167	167	167
P	Viewing direction downwards	-	92	-	92

- 1) Cooling water inlet for base plate 1/2" female thread
- 2) Cooling water outlet for base plate 3/4" female thread
- 3) Probe camera housing with straight view direction
- 4) Probe camera housing with elbow view direction
- 5) Service position of the camera housing (90° to the left or right)

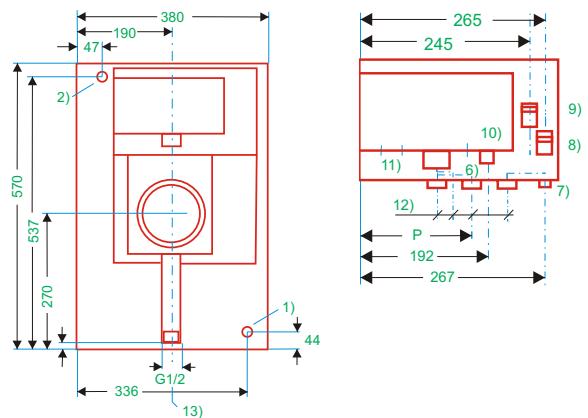

- 6) Cooling water inlet for probe camera housing (ferrule screw gland for 12 mm outer diameter).
- 7) Cooling water outlet for probe camera housing (ferrule screw gland for 12 mm outer diameter)
- 8) Working air for retraction process (screwed gland for tube with 8 mm outer diameter)
- 9) Working air for probe's insertion (screwed gland for tube with 8 mm outer diameter)
- 10) Purging air inlet (screwed gland for tube with 8 mm outer diameter)
- 11) Screwed glands for cable diameter 6 - 9 mm or 12 - 14 mm
- 12) Connections for cooling water and purging air to probe camera housing
- 13) Cooling air connection of the nozzle R 1 1/2", male thread



Control Unit G24N



Control unit G24N

The control unit automatically controls the movement of the retraction device in the case of failure of the compressed air supply, violation of the cooling water temperature limit or power supply failure by means of the compressed air unit. Moreover it is possible to retract and insert the probe camera manually via the control unit for purpose as cleaning, checking and servicing. The unit should therefore always be installed in direct line of sight to the camera. Insertion is only possible, actuation the 'insertion' key.

The control unit contains 2 keys for insertion and retraction, a control voltage pilot lamp (mains) and 2 lamps for the operation media water and air. It is prepared for looping-in further control contacts; switching off the purging air is possible.

The valves of the compressed air unit are powered via the control unit. Remote controlled retraction and display is possible.

Units may be supplied in various performance, e.g. standard, with key switch, with 2-wire transmitter, remote control unit a.s.o.

Technical data

Power supply	240/220/110 VAC -10 % to + 10 %, ≤ 50 VA
Degree of protection	IP 54 to DIN 40050
Mounting position	any
Temperature of use	-10 °C to + 50 °C
Attachment	4 holes of 9 mm diam. for direct wall installation or 4 mounting brackets for M8 screws
Cable inlets	screwed glands for cable diam. 6-9 mm
Dimensions	400 x 300 x 155 mm
Weight	appr. 8 kg

Ordering data

Item	Order no.:
Control unit G24N	2GF1801 - <input type="checkbox"/> 8 <input type="checkbox"/> A <input type="checkbox"/> F <input type="checkbox"/> <input type="checkbox"/> - <input type="checkbox"/>
Standard design of control unit	
without key switch	0
with key switch	1
without 2-wire transmitter	0
with 2-wire transmitter	1
without remote control access to camera	- 0
with remote control access to camera (RS232)	- 1



Cooling water unit

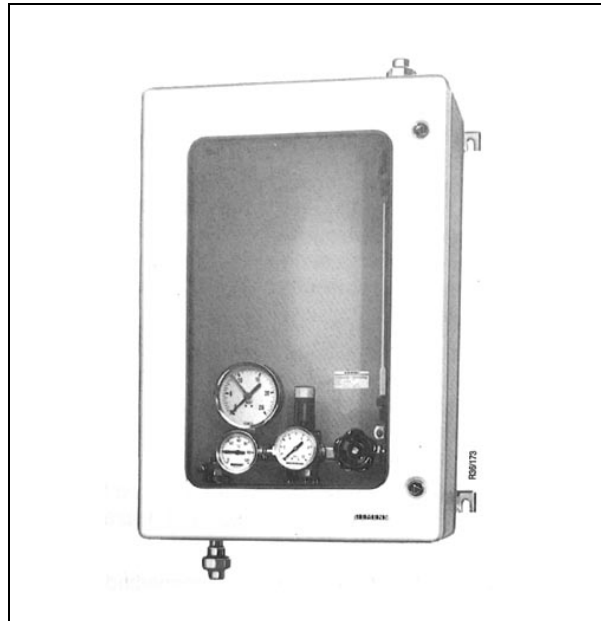

Cooling water unit

Cooling water unit for supply, monitoring, control and adjustment of the cooling water for the probe camera housing.

The main components are the shut-off valve, input manometer, thermometer, control valve for the stabilization of the water supply pressure. Pressure regulator with dirt filter (width of mesh appr. 0,16 mm), needle valve for the flow regulation and the flow meter, graduated from 120 to appr. 1020 l/h = 2 to 17 l/min.

Technical data

Inlet

Cooling water	clean filtered, chemically non corrosive water
Required input	4 bar to 16 bar overpressure
- Flow rate	2 l/min to 20 l/min
- Temperature	25 °C to 38 °C
- Conductivity	≤ 0,5 mS/cm
- pH value	6 to 7,5
- suspended matter	≤ 10 mg/l
- total hardness	≤ 3,6 mval/l (10 °dH)
- outlet pressure	max. 4 bar (2 bar preadjusted)

Installation	vertical ± 2°
Degree of protection	IP 00 (on mounting plate), DIN 40050 IP 54 (in wall housing), DIN 40050
Temperature of use	+5 °C to +50°C
Weight:	appr. 20 kg (for in-wall housing)
Distance to the retraction device	max. 10 m
Performance	
- Cabinet	closed cabinet with door door with window
- Attachment	4 holes, Ø 9 mm for direct mounting 4 mounting brackets for M8 screws
- Double section	Mounting plate with tapped holes for installation for cooling water units and compressed air unit.
- Dimensions	600 x 400 x 200 mm

Ordering data

Item	Order no.:
Cooling water unit	2GF1704 - 8 A <input type="checkbox"/> <input type="checkbox"/> <input type="checkbox"/> - <input type="checkbox"/>
Complete with tubes	
- on mounting plate	A
- in wall housing	B
Set of cooling water parts	2FG1704 - 8 A E
Consistion of thermometer, control valve, needle valve for installation into ½" pipeline (available on site)	



Compressed air unit

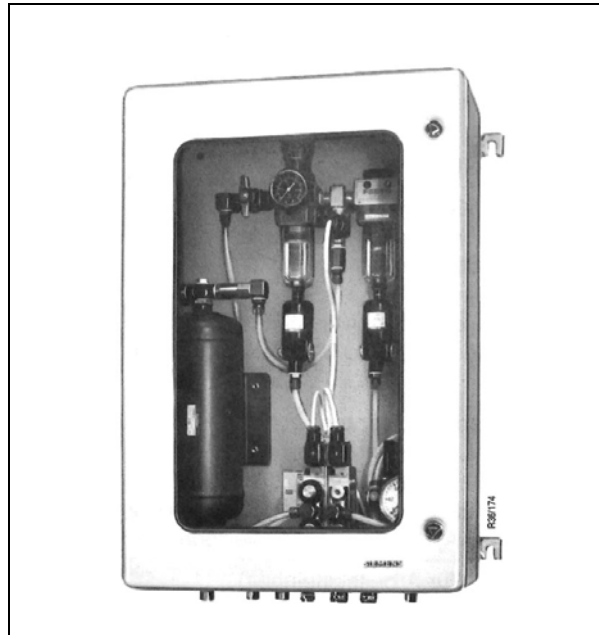

Compressed air unit

Compressed air unit for monitoring, processing and controlling the compressed air for the working air of the stroke cylinder in the retraction device and for the purging air to the probe camera housing, for storage of working air and for reversing and controlling the speed of the stroke cylinder. The basic model comprises all units for controlling and filtering the compressed air. It consists of working and purging air units.

The working air unit contains a working air valve with 2 throttle valves for separate adjustment of the insertion and retraction speeds.

The standby air reservoir (2 dm³) with check valve ensures safe extraction of the probe camera even upon failure of the compressed air supply.

The purging air unit includes a pre- and superfine filter, both with automatic condensate outlet. To ensure constant cooling of the front lens - even upon failure of the compressed air supply - the unit is available with a 5-l air reservoir (mounted outside the housing) for emergency purging air supply.

2 automatic outlet valves for condensate, 1 purging air valve for stopping the purging air with the camera retracted as well as a double-section wall housing for installing the compressed air unit, the cooling water unit and the control unit are provided in addition.

The working air and purging air units are available either separately or connected on a single mounting plate suitable for installation in the wall housing or in the double-section wall housing.

The compressed air unit can be only delivered for purging air processing if the probe camera is installed permanently.

If the temperature of the compressed air is higher than the temperature of the cooling water supply for the probe camera housing, the unit with compressed air outlet can be ordered with an attached cooling drier which cools the air to prevent the formation of condensate inside the probe camera housing.

Technical data

Inlet	
- Compressed air	6 to 10 bar overpressure
- Temperature	≤ temperature of cooling water at the inlet of the probe camera housing; with air drier: max 37 °C
- Consumption	appr. 2m ³ /h
Outlets	
- Working air	5 µm, filtered air
- Overpressure	4 to 8 bar
- Purging air	filtration degree 99,999 % referring to solids of 0,01 µm diameter
- Overpressure	0,2 bar to 0,3 bar (max. 2,5 bar)
Voltage for working- and purging air valve (solenoid valve)	24V DC
Installation	vertical ± 5°
Degree of protection	IP 00 (on mounting plate), DIN 40050 IP 54 (in wall housing), DIN 40050
Temperature of use	+5 °C to +50°C
Weight	appr. 25 kg (for in-wall housing)
Distance to the retraction device	max. 10 m
Attachment	4 holes, Ø 9 mm for direct mounting 4 mounting brackets for M8 screws
Double section	Mounting plate with tapped holes for installation for cooling water units and compressed air unit.
Dimensions	600 x 400 x 200 mm



Compressed air unit

Ordering data

Item	Order no.:					
Compressed air unit	2GF1703 - <input type="checkbox"/> <input type="checkbox"/> <input type="checkbox"/> <input type="checkbox"/> <input type="checkbox"/> - <input type="checkbox"/>					
Working- and purging air units						
- with working- and purging air units 1)	1					
- with working air unit 1)	2					
- with purging air unit	3					
- with working air unit 1) with compressed air outlet (for purging air processing via cooling drier)	4					
Design						
- on mounting plate, complete with tubes		A				
- in wall housing, complete with tubes		B				
- in double section wall housing, including installation of a cooling water unit (2GF1704-8AA), which must be ordered separately; both complete with tubes		C				
Working air valve (for working air unit)						
- without working air valve		A				
- with working air valve for DC 24 V 2)		C				
Purging air valve (for purging air unit and Working air unit with compressed air outlet)						
- without purging air valve			0			
- with purging air valve 3) for DC24 V 2)			2			
Condensate outlet screw / valve						
- with condensate outlet screw(s)			0			
- with automatic condensate outlet valve for:						
working air unit			1			
purging air unit			2			
working- and purging air units			3			
Emergency purging air supply (for purging air unit)						
- without emergency purging supply					-	0
- with 10-l compressed air reservoir for emergency purging air supply, complete with tubes					-	1
Double section wall housing	2GF1703-8HA					

- 1) working air valve required
- 2) the voltage has to correspond to the voltage of the control unit
- 3) limit switch in the retraction device necessary



System accessories

Reversible flow filter

Reversible flow filter for filtering the cooling water for the probe camera housing upstream of the cooling water unit. Automatic backwashing when opening a drain valve.

Technical data

Connections	R 1/2" (male thread with screwed glands)
Filter	mesh width 50 µm
Manometer	0 to 6 bar
Pressure	1,5 to 16 bar (at the inlet)
Water temperature	max 40 °C
Flow rate	2,7 m ³ /h with ΔP = 0,2 bar
Temperature of use	+ 5 °C to + 50 °C

Ordering data

Item	Order no.:	Weight (kg)
Reversible flow filter	2GF1704-8AF	1,2

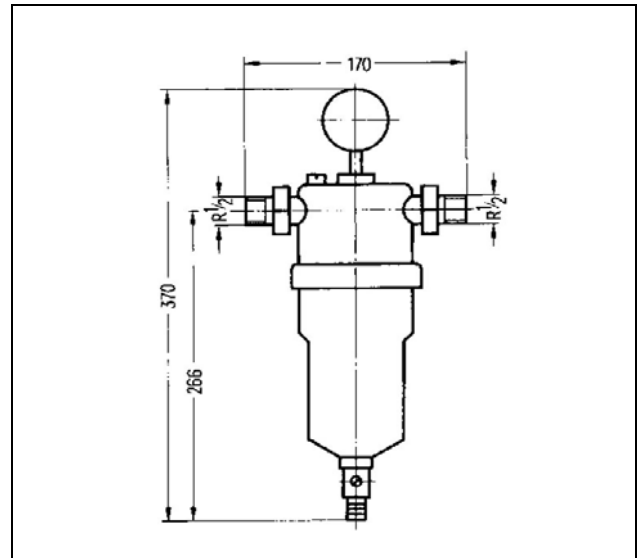

Cooling air switch

Cooling air switch for monitoring the cooling air pressure in systems with cooling air connection. Installation upstream of the cooling air connection. Electrically connected to the control unit.

Technical data

Switching points	10 mbar: lower switching point 80 mbar: upper switching point
Pressure gauge	0 bar to 0,6 bar
Connections	R 1 1/2" (female thread) M 12 screwed gland
Degree of protection	IP 40 to DIN 40050
Temperature of use	- 10 °C to + 60 °C

Ordering data

Item	Order no.:	Weight (kg)
Cooling air switch	2GF1703-8GA	0,8

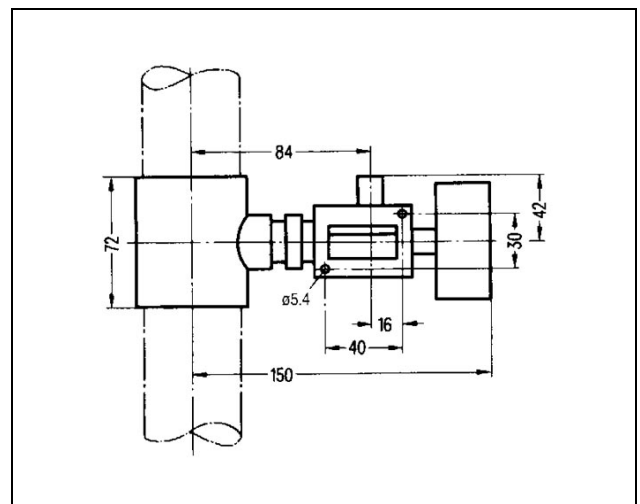

Compressed air switch

Compressed air switch for monitoring the compressed air in systems, operating with a cooling air drier.

Technical data

Switching points	adjustable from 1 to 10 bar, the upper switching point is 0,5 bar above the lower one
Connections	R 1/4" (female thread)
Cable gland	M12 for cable diameter 5-10 mm
Degree of protection	IP 56 to DIN 40050
Mounting position	any
Temperature of use	-20 °C to +100 °C

Ordering data

Item	Order no.:	Weight (kg)
Compressed air switch	2GF1703-8DA	0,4

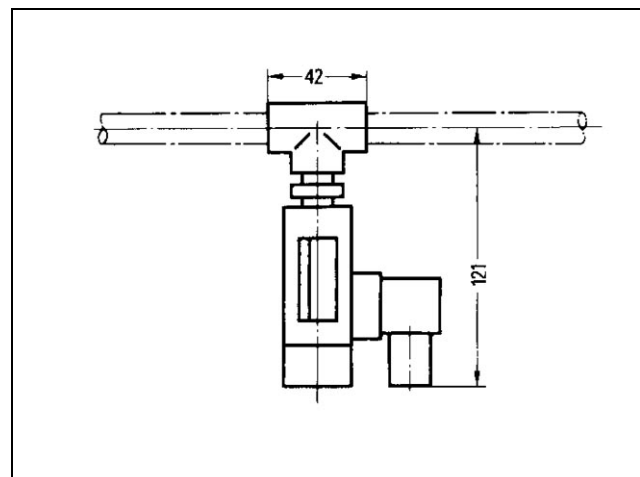



System accessories

Thermometer with T-pice

Thermometer with T-pice for measuring the temperature of the cooling water outlet flow or the temperature of the purging air.

Technical data

Scale	0 °C to 120 °C
Connections	R 1/2" (female thread with 2 adapters to 1/4" female thread, also suitable for tube of 8 mm diameter.
Mounting position	any

Ordering data

Item	Order no.:	Weight (kg)
Thermometer with T-pice	2GF1704-8BA	0,4

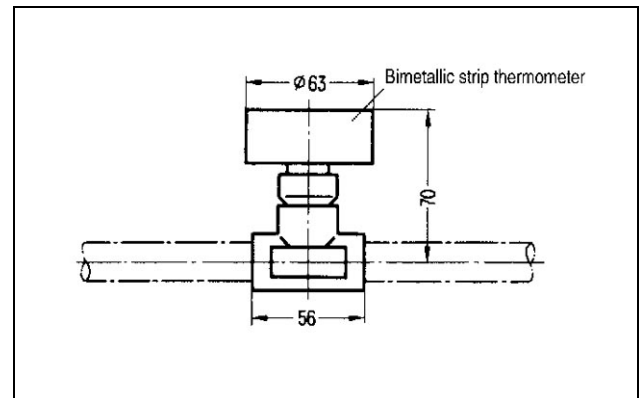

Tube and cable set

Tube and cable set for connection of the probe camera to the junction box and the cooling water supply.

Ordering data

Item	Order no.:	Weight (kg)
Tube and cable set For probe camera housing	2GF1810-8FF	2,0

Technical data

Tube and cable set D22	for furnace probe cameras B1317F / C1317F
Purging air tube	2 m long, 22 mm diameter
2 water tubes	2 m long, 12 mm diameter connect. For ferrule screw glands
thermal control cable	2,8 m long, 2 signal conductors



Component list

Component list

Component list on request