

# FAM3200

## Armored Variable Area Purgemeter

Measurement made easy



### Short product description

Armored Variable Area Purgemeter for flow measurement of fluids and gases.

### Further information

Additional documentation on FAM3200 is available to download free of charge at [www.abb.com/flow](http://www.abb.com/flow).

Alternatively simply scan this code:



### Manufacturer

**ABB Automation Products GmbH**

**Measurement & Analytics**

Dransfelder Str. 2

37079 Göttingen

Germany

Tel: +49 551 905-0

Fax: +49 551 905-777

### Customer service center

Tel: +49 180 5 222 580

Mail: [automation.service@de.abb.com](mailto:automation.service@de.abb.com)

# Contents

<b>1</b>	<b>Safety</b> .....	<b>4</b>	<b>8</b>	<b>Maintenance / Repair</b> .....	<b>14</b>
1.1	General information and instructions .....	4	8.1	Spare parts.....	14
1.2	Warnings .....	4	8.2	Cleaning .....	14
1.3	Intended use.....	4	8.2.1	Disassembly of the meter tube.....	14
1.4	Improper use .....	5	8.3	Returning devices .....	15
1.5	Warranty provisions .....	5	<b>9</b>	<b>Recycling and disposal</b> .....	<b>15</b>
<b>2</b>	<b>Use in potentially explosive atmospheres</b> .....	<b>6</b>	9.1	Dismounting .....	15
2.1	Ex-marking .....	6	9.2	Disposal.....	16
2.2	Temperature data .....	6	<b>10</b>	<b>Specifications</b> .....	<b>16</b>
2.3	Installation .....	6	10.1	Material load .....	16
2.3.1	Electrical connections .....	6	10.2	Measuring range table .....	17
2.4	Limit value tables .....	7	10.2.1	Model FAM3220 / FAM3250 / FAM3225 / FAM3255, variable area and armored.....	17
<b>3</b>	<b>Functional description</b> .....	<b>8</b>	10.2.2	Model FAM3225 / FAM3255, conical float and orifice plate .....	18
<b>4</b>	<b>Product identification</b> .....	<b>8</b>	<b>11</b>	<b>Additional documents</b> .....	<b>18</b>
4.1.1	Name plate.....	8	<b>12</b>	<b>Appendix</b> .....	<b>19</b>
4.1.2	Factory plate.....	9	12.1	Return form .....	19
<b>5</b>	<b>Transport and storage</b> .....	<b>9</b>			
5.1	Inspection.....	9			
5.2	Transport.....	9			
5.3	Storage .....	9			
5.4	Returning devices .....	9			
<b>6</b>	<b>Installation</b> .....	<b>10</b>			
6.1	Safety instructions .....	10			
6.2	Installation conditions.....	10			
6.2.1	General.....	10			
6.2.2	Installation recommendations.....	10			
6.2.3	Pressure chambers and collecting tanks .....	10			
6.2.4	Sensor insulation .....	10			
6.2.5	Heat tracing.....	11			
6.3	Operating conditions.....	11			
6.3.1	Pressure loss .....	11			
6.3.2	Prevention of compression oscillations when measuring gases .....	11			
6.3.3	Pressure shocks .....	11			
6.3.4	Solids content in the measuring medium.....	12			
6.4	Installation .....	12			
6.4.1	General information.....	12			
6.4.2	Flowmeter installation.....	12			
6.5	Electrical connections .....	12			
6.5.1	Analog indicator with alarm signaling unit .....	12			
6.5.2	Switching amplifier .....	13			
6.5.3	Analog indicator with transmitter .....	13			
<b>7</b>	<b>Commissioning</b> .....	<b>13</b>			
7.1	Adjusting the alarm signalling unit.....	13			
7.2	Operating instructions.....	13			

# 1 Safety

## 1.1 General information and instructions

These instructions are an important part of the product and must be retained for future reference.

Installation, commissioning, and maintenance of the product may only be performed by trained specialist personnel who have been authorized by the plant operator accordingly. The specialist personnel must have read and understood the manual and must comply with its instructions.

For additional information or if specific problems occur that are not discussed in these instructions, contact the manufacturer.

The content of these instructions is neither part of nor an amendment to any previous or existing agreement, promise or legal relationship.

Modifications and repairs to the product may only be performed if expressly permitted by these instructions.

Information and symbols on the product must be observed.

These may not be removed and must be fully legible at all times.

The operating company must strictly observe the applicable national regulations relating to the installation, function testing, repair and maintenance of electrical products.

## 1.2 Warnings

The warnings in these instructions are structured as follows:

### DANGER

The signal word "DANGER" indicates an imminent danger. Failure to observe this information will result in death or severe injury.

---

### WARNING

The signal word "WARNING" indicates an imminent danger. Failure to observe this information may result in death or severe injury.

---

### CAUTION

The signal word "CAUTION" indicates an imminent danger. Failure to observe this information may result in minor or moderate injury.

---

### NOTE

The signal word "NOTE" indicates useful or important information about the product.

The signal word "NOTE" is not a signal word indicating a danger to personnel. The signal word "NOTE" can also refer to material damage.

---

## 1.3 Intended use

This device is intended for the following uses:

- To convey liquids, gases (including unstable liquids and gases) and vapors.
- To measure the flow of the operating volume under constant operating conditions (pressure, temperature, density). An output of the flow is also possible in standard or mass units.

The device has been designed for use exclusively within the technical limit values indicated on the name plate and in the data sheets.

The following technical limit values must be observed:

- The permissible pressure (PS) in the permissible measuring medium temperature (TS) may not exceed the pressure-temperature ratings.
- The maximum or minimum operating temperature must not be exceeded or undershot.
- The permissible ambient temperature must not be exceeded.

When using media for measurement the following points must be observed:

- Measuring media may only be used if, based on the state of the art or the operating experience of the user, it can be assured that the chemical and physical properties necessary for safe operation of the materials of transmitter components coming into contact with these will not be adversely affected during the operating period.
- Media containing chloride in particular can cause corrosion damage to stainless steels which, although not visible externally, can damage wetted parts beyond repair and lead to the measuring medium escaping. It is the operator's responsibility to check the suitability of these materials for the respective application.
- Measuring media with unknown properties or abrasive measuring media may only be used if the operator can perform regular and suitable tests to ensure the safe condition of the meter.

The operator bears sole responsibility for the use of the devices in relation to suitability, intended use and corrosion resistance of the materials in relation to the measuring medium.

The manufacturer is not liable for damage arising from improper or non-intended use.

Repairs, alterations, and enhancements, or the installation of replacement parts, are only permissible insofar as these are described in this manual. Approval by ABB Automation Products GmbH must be sought for any activities beyond this scope. Repairs performed by ABB-authorized specialist shops are excluded from this.

#### **1.4 Improper use**

The following are considered to be instances of improper use of the device:

- For operating as a flexible adapter in piping, e.g. for compensating pipe offsets, pipe vibrations, pipe expansions, etc.
- For use as a climbing aid, e.g. for mounting purposes
- For use as a support for external loads, e.g. as a support for piping, etc.
- Material application, e.g. by painting over the name plate or welding/soldering on parts
- Material removal, e.g. by spot drilling the housing

#### **1.5 Warranty provisions**

Using the device in a manner that does not fall within the scope of its intended use, disregarding this manual, using underqualified personnel, or making unauthorized alterations releases the manufacturer from liability for any resulting damage. This renders the manufacturer's warranty null and void.



## 2.4 Limit value tables

### Devices for use in category 1 (zone 0 in meter tube)

Equipment:  $T_{\text{medium}} = T_{\text{ambient}} \geq -20\text{ °C}$  (-4 °F)

Atmospheric conditions: 0.8 ... 1.1 bar (11.6 ... 15.95 psi)

Category 1 refers to the interior of the meter tube. Ensure that the ambient conditions are suitable for devices in zone 1 (e.g. by ensuring sufficient ventilation).

Electrical data					Permissible ambient temperature $T_{\text{ambient}}$										
					40 °C (104 °F)			50 °C (122 °F)			60 °C (140 °F)				
					Permissible measuring medium temperature $T_{\text{medium}}$ in the relevant temperature class [°C (°F)]										
$U_i$ [V]	$I_i$ [mA]	$P_i$ [mW]	$C_i$ [nF]	$L_i$ [μH]	T6	T5	T4	T6	T5	T4	T6	T5	T4		
16	25	34	30	100	60	60	60	60	60	60	60	60	60	60	
					(140)	(140)	(140)	(140)	(140)	(140)	(140)	(140)	(140)	(140)	(140)
	25	64			60	60	60	60	60	60	60	60	60	60	60
					(140)	(140)	(140)	(140)	(140)	(140)	(140)	(140)	(140)	(140)	(140)
	52	169			50	60	60	35	60	60	25	60	60		
					(122)	(140)	(140)	(95)	(140)	(140)	(77)	(140)	(140)		
	76	242			10	50	60	—	35	60	—	25	50		
					(50)	(122)	(140)		(95)	(140)		(877)	(122)		

### Devices for use in category 2 (zone 1)

Equipment:  $T_{\text{medium}} = T_{\text{ambient}} \geq -20\text{ °C}$  (-4 °F)

Electrical data					Permissible ambient temperature $T_{\text{ambient}}$											
					40 °C (104 °F)			50 °C (122 °F)			60 °C (140 °F)					
					Permissible measuring medium temperature $T_{\text{medium}}$ in the relevant temperature class [°C (°F)]											
$U_i$ [V]	$I_i$ [mA]	$P_i$ [mW]	$C_i$ [nF]	$L_i$ [μH]	T6	T5	T4	T3	T6	T5	T4	T3	T6	T5	T4	T3
16	25	34	30	100	85	100	135	180	85	100	135	165	85	100	135	155
					(185)	(212)	(275)	(356)	(185)	(212)	(275)	(329)	(185)	(212)	(275)	(311)
	25	64			85	100	135	180	85	100	135	165	70	100	135	155
					(185)	(212)	(275)	(356)	(185)	(212)	(275)	(329)	(158)	(212)	(275)	(311)
	52	169			50	85	130	130	35	70	115	115	25	60	100	100
					(122)	(185)	(266)	(266)	(95)	(158)	(239)	(239)	(77)	(140)	(212)	(212)
	76	242			10	50	80	80	—	35	65	65	—	25	50	50
					(50)	(122)	(176)	(176)		(95)	(149)	(149)		(77)	(122)	(122)

### 3 Functional description

The flowmeters in the FAM3200 work according to the float principle.

The position of the float in the conical meter tube is proportional to the flow.

A magnet in the float translates the height of the float as a measurement for the flow to the decouple-proof magnet follower system of the flowmeter.

The flow rate value is indicated on a scale by a pointer mounted on a rotating shaft.

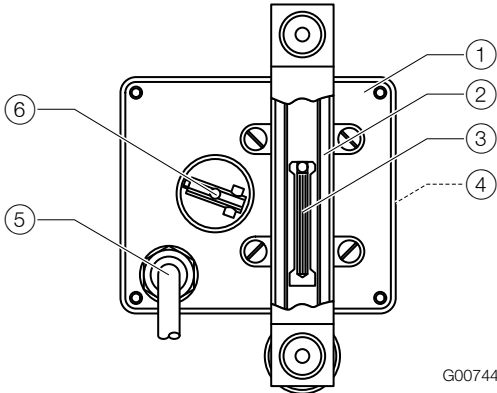

Fig. 2: Structure (example)

- ① Meter housing
- ② Meter tube
- ③ Float with magnet
- ④ Indicator housing
- ⑤ Magnet follower system
- ⑥ Cable entry

The devices are used for local indication of the current flow rate with integrated alarm signalling units as flow rate monitors or with differential pressure regulators.

The devices are also available with an angular position transmitter with 4 ... 20 mA output signal as an option.

### 4 Product identification

#### 4.1.1 Name plate

The name plate is located on the indicator housing.

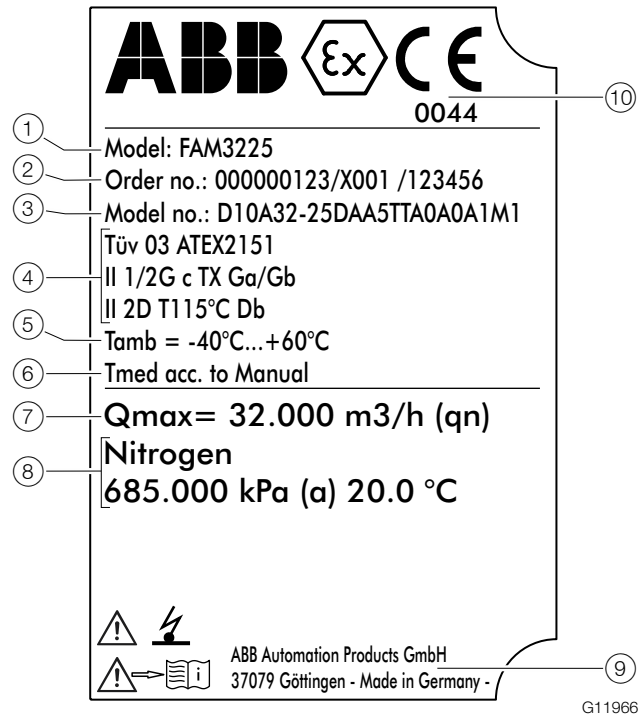

Fig. 3: Name plate (example)

- ① Type designation
- ② Serial number
- ③ Order number
- ④ ATEX marking
- ⑤ Ambient temperature
- ⑥ Measuring medium temperature
- ⑦ Maximum flow rate
- ⑧ Details of measuring medium
- ⑨ Manufacturer's address
- ⑩ CE mark

#### **i** NOTE

The information on the permissible measuring medium temperature ( $T_{med}$ ) can be found in chapter "Specifications" on page 16.



### 4.1.2 Factory plate

In addition to the name plate, the factory plate is also on the meter tube of the flowmeter.

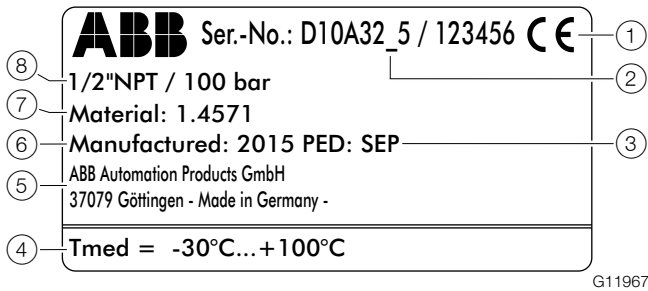

Fig. 4: Factory plate

- ① CE mark
- ② Serial number of the sensor
- ③ Reason for exception under article 4, paragraph 3 of the Pressure Equipment Directive
- ④ Measuring medium temperature
- ⑤ Manufacturer's address
- ⑥ Year of construction
- ⑦ Material of the pressure-bearing part (wetted part)
- ⑧ Nominal diameter / nominal pressure rating

The reason for exception according to article 4 paragraph 3 of the Pressure Equipment Directive is specified under PED. The pressure equipment is classified in the SEP (= Sound Engineering Practice) "Good Engineering Practice" category.

#### **i** NOTE

The measuring medium temperature specified on the factory plate only applies for the meter tube. Depending on the device design (options, Ex approval), the permissible measuring medium temperature may deviate from the specified range.

The information on the permissible measuring medium temperature ( $T_{med}$ ) can be found in chapter "Specifications" on page 16.

## 5 Transport and storage

### 5.1 Inspection

Check the devices immediately after unpacking for possible damage that may have occurred from improper transport. Details of any damage that has occurred in transit must be recorded on the transport documents. All claims for damages must be submitted to the shipper without delay and before installation.

### 5.2 Transport

- The center of gravity of some devices is not at the center of the equipment.
- Use the any available attachment points on the device for transport.
- Ensure that all transport locking devices are available and correctly installed.
- Transport packaging marked visibly with the note "Caution Glass".

### 5.3 Storage

- Bear the following points in mind when storing devices:
- Store the device in its original packaging in a dry and dust-free location.
  - Observe the permitted ambient conditions for transport and storage.
  - Avoid storing the device in direct sunlight.
  - In principle, the devices may be stored for an unlimited period. However, the warranty conditions stipulated in the order confirmation of the supplier apply.

The ambient conditions for the transport and storage of the device correspond to the ambient conditions for operation of the device.

Adhere to the device data sheet!

### 5.4 Returning devices

For the return of devices, follow the instructions in the chapter "Returning devices" on page 15.

## 6 Installation

### 6.1 Safety instructions

#### **⚠ WARNING**

##### **Risk of injury due to process conditions.**

The process conditions, e.g. high pressures and temperatures, toxic and aggressive measuring media, can give rise to hazards when working on the device.

- Before working on the device, ensure that the process conditions do not pose any safety risks.
- If necessary, wear suitable personal protective equipment when working on the device.
- Depressurize and empty the device / piping, allow to cool and purge if necessary.

### 6.2 Installation conditions

#### 6.2.1 General

The following points are to be considered during installation:

- The armored variable area flowmeter is installed vertically in piping. The measuring media must flow from bottom to top.
- Keep the device as far as possible from pipe vibrations. Fastening the piping is normally sufficient.
- Keep the device as far as possible from powerful magnetic fields. Magnetic fields that are required for operating reasons must not influence the measurement result.
- The piping should be the same size as the connection size of the flowmeter.
- Inlet and outlet sections are not required. Valves and pipe bends can be screwed on directly.
- Avoid pulsating flows and sudden pressure surges.
- Use slow opening valves.
- If the flowmeter is installed in a pipeline where decommissioning is impossible or inexpedient, a bypass line should be provided.
- For gaseous measurement media, the flowmeter should be installed as close as possible to the pipe constrictions. The nominal diameter of the piping at the outlet of the flowmeter should be measured as small as possible.
- Shut-off and throttle valves should preferably be attached to the outlet of the flowmeter.
- For liquid measuring media, the nominal size of the piping should be dimensioned as large as possible (if economically viable).

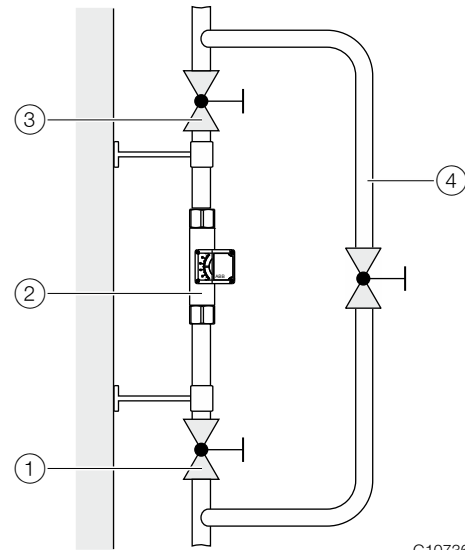

Fig. 5: Installation of the flowmeter

- ① Shut-off valve in the inlet
- ② Flowmeter
- ③ Shut-off valve in the outlet
- ④ Bypass line

#### 6.2.2 Installation recommendations

Refer to VDI / VDE Directive 3513 sheet 3, Selection and Installation Recommendations for Variable Area Flowmeters.

#### 6.2.3 Pressure chambers and collecting tanks

If piston pumps or compressors are used for the transport of the measuring media, a pulsating flow of the measurement media must be expected.

In order to reduce the pulsating of the float, the installation of pressure chambers or collecting tanks in the piping before the flowmeter is recommended.

#### 6.2.4 Sensor insulation

If the flowmeter needs to be insulated, only the meter tube must be included in the pipe insulation. The indicator housing must not be insulated.

This prevents the temperature in the device from rising beyond permitted limits.

### 6.2.5 Heat tracing

Trace heating may be used under the following conditions:

- The heat tracing must be installed in a way that ensures there is no temperature increase in the indicator housing.
- The maximum permitted temperature of the heat tracing must not exceed the permitted measuring medium temperature.
- When using electrical heat tracing, attention must be paid to potential functional impairment by electromagnetic fields.

## 6.3 Operating conditions

A variable area flowmeter is specified for a defined set of operating conditions of the measuring medium. For liquids and gases, these are pressure and temperature-related properties (density and viscosity) under operating conditions.

For gases, in particular, this means operating at a specific operating pressure and operating temperature. The specified accuracy of the device always refers to the operating conditions underlying the specification.

### 6.3.1 Pressure loss

The available operating pressure at the measuring point must be higher than the pressure loss listed for the flowmeter in the specifications.

It is important to also consider the pressure loss downstream from the flowmeter due to losses in the piping and other fittings.

For information on pressure loss, see chapter "Measuring range table" on page 17.

### 6.3.2 Prevention of compression oscillations when measuring gases

With low flow amounts and low operating pressure, so-called compression oscillations of the float can occur.

If the maximum upstream pressure listed in the specifications is not reached, the flowmeter can optionally be equipped with a mechanical float damper.

Damping is available for the device types FAM3225 and FAM3255 with a process connection size > 1/4".

To prevent self-generated compression oscillations, note the following information from VDI / VDE 3513 Sheet 3:

- Select a flowmeter with the lowest possible pressure loss.
- Minimize the piping length between the flowmeter and the closest up or downstream throttling location.
- Restrict the usual measuring range from the usual 10 ... 100 % to 25 ... 100 %.
- When setting the flow rate value, always start assuming larger values.
- Increase the operating pressure and consider its effect on the flow rate values due to the change in gas density at the new operating conditions.
- Minimize non-throttled, free volumes upstream and downstream of the device.

### 6.3.3 Pressure shocks

Especially when measuring gases, it is possible that pressure or shock waves can occur when fast opening solenoid valves are employed and the piping cross-sections are not throttled, or if there are gas bubbles in liquids.

As a result of the sudden expansion of the gas in the piping, the float is forcibly driven against the upper floatstop. Under certain conditions, this can lead to destruction of the device.

The mechanical float damping is not suitable for the compensation of pressure shocks!

### 6.3.4 Solids content in the measuring medium

Variable area flowmeters have only limited suitability for measuring media containing solids. Depending on the concentration, particle size and type of solid, increased mechanical abrasion may occur, especially at the critical measuring edge of the float. In addition, solidified deposits on the float can change its weight and shape. These effects can lead to erroneous measurement results, depending on the float type. In general, the use of appropriate filters is recommended in such applications. For the flow measurement of measuring media containing magnetic particles, we recommend the installation of a magnetic separator upstream of the variable area flowmeter.

## 6.4 Installation

### 6.4.1 General information

The flowmeters in the FAM3200 series are intended for vertical pipe mounting.

The following points must be observed during installation in the piping:

- The measuring medium must flow from bottom to top.
- The piping may not exert any impermissible forces or torques on the device. The device must be disconnected from the power supply for installation.
- Only gaskets made from a material that is compatible with the measuring medium and measuring medium temperature may be used
- Gaskets must not extend into the flow area since possible turbulence could influence device accuracy.

### 6.4.2 Flowmeter installation

Install the flowmeter centrally in the piping at the required position using the correct threaded connections. When tightening the process connections on the flowmeter, use a spanner of the corresponding size to counter the force.

Model	Meter size	Wrench size [mm]
FAM3220 / FAM3250	1/4"	SW 22
FAM3225 / FAM3255	1/4"	SW 19
	3/8"	SW 24
	1/2"	SW 27
	1"	SW 50

Check the process connections for tightness.

## 6.5 Electrical connections

### 6.5.1 Analog indicator with alarm signaling unit

#### **i** NOTE

When using the device in potentially explosive atmospheres, observe the connection data in chapter "Use in potentially explosive atmospheres" on page 6!

#### Specifications

Operating mode	bistable
Switching function	NAMUR contact
Nominal voltage	8 V DC (Ri approx. 1 kΩ)
Operating voltage	5 ... 25 V DC
Switching frequency	Maximum 5 kHz
Connection type	Cable, 2-wire, brown (+) / blue (-), length 1.75 m (5.74 ft) <sup>1)</sup>
Switching point single alarm	Minimum 0 ... 60 %
	Maximum 40 ... 100 %
Switching point double alarm	Minimum setting range approx. 5 %
Setting accuracy	±2 % of measured value
Reproducibility	±0.5 % of scale end value

1) Other cable lengths available on request.

#### Temperature and electrical data

The following table shows the maximum permitted measuring medium temperature  $T_{\text{medium}}$  and the permitted electrical data depending on the ambient temperature  $T_{\text{ambient}}$  and the gasket material.

Electrical data		Ambient temperature $T_{\text{ambient}}$					
		40 °C (104 °F)		50 °C (122 °F)		60 °C (140 °F)	
$I_j$ [mA]	$P_j$ [mW]	$T_{\text{medium}}$ maximum [°C (°F)]					
		(A)	(B)	(A)	(B)	(A)	(B)
25	34	100 (212)	180 (356)	100 (212)	165 (329)	100 (212)	155 (311)
25	64	100 (212)	180 (356)	100 (212)	165 (329)	100 (212)	155 (311)
52	169	100 (212)	130 (266)	100 (212)	115 (239)	100 (212)	100 (212)
76	242	80 (176)	80 (176)	65 (149)	65 (149)	50 (122)	50 (122)

(A) Gasket material Buna N (B) Gasket material Viton A / Kalrez

### 6.5.2 Switching amplifier

Additional switching amplifiers are needed to operate the alarm signaling units.

See chapter "Switching amplifier" on page 13 and the "Ordering information" section of the data sheet for further information.

Specifications	
Power supply	230 V AC, +10 % / -15 %, 45 ... 60 Hz 115 V AC, +10 % / -15 %, 45 ... 60 Hz 24 V DC, +10 % / -15 %
Output	One or two switching relays with potential-free changeover contacts
Switching capacity	Maximum 250 V, maximum 4 A, maximum 500 VA
Maximum permissible cable length	Between switch amplifier and alarm signaling unit: 300 m (984 ft)
Permissible ambient temperature range	-20 ... 60 °C (-4 ... 140 °F)
Electrical connection	Screw terminals, maximum 2.5 mm <sup>2</sup> (14 AWG)
Type of assembly	35 mm top-hat rail in accordance with EN 60715:2001
IP rating	IP 20 in accordance with EN 60529
Weight	Approx. 150 g (0.3 lb)

### 6.5.3 Analog indicator with transmitter

Specifications	
Output signal	4 ... 20 mA, two-wire technology
Power supply	maximum 30 V DC
Power consumption	Maximum 30 mA
Connection type	Cable, 2-wire, brown (+) / blue (-), length 1.75 m (5.74 ft) <sup>1)</sup>
Ambient temperature range	-20 ... 40 °C (-4 ... 104 °F)
Version	Angular position transmitter in two-wire technology

1) Other cable lengths available on request.

## 7 Commissioning

### ⚠ CAUTION

#### Risk of burns due to hot measuring media.

The device surface temperature may exceed 70 °C (158 °F), depending on the measuring medium temperature!

Before starting work on the device, make sure that it has cooled sufficiently.

During commissioning of the flowmeter, observe the following points:

- The ambient and operating conditions (pressure, temperature, power supply) must correspond to the details on the name plate and the specifications.
- Open the shut-off valves slowly in order to prevent pressure surges that can damage the flowmeter.
- For liquid measurement media, vent the pipeline if necessary.
- For devices with alarm signalling units, set these to the required switching points.

### 7.1 Adjusting the alarm signalling unit

The alarm signalling unit is designed as a proximity switch. When inserted in the proximity switch, the metal tag initiates the switching process. The switching point can be adjusted with a screwdriver.

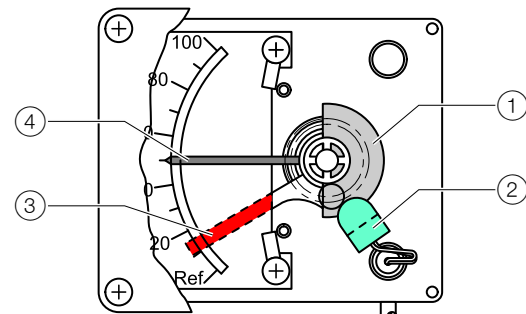

G00745

Fig. 6: Single alarm (example)

- ① Metal tag ② Alarm signalling unit (proximity switch)  
③ Alarm adjustment ④ Indicator

1. Unscrew the housing cover.
2. Adjust the alarm setting to the required switching point using a flat-bladed screwdriver.
3. Screw on housing cover.

### 7.2 Operating instructions

If there is a chance that safe operation is no longer possible, take the device out of operation and secure it against unintended startup.

## 8 Maintenance / Repair

### ⚠ WARNING

#### Risk of injury due to process conditions.

The process conditions, e.g. high pressures and temperatures, toxic and aggressive measuring media, can give rise to hazards when working on the device.

- Before working on the device, ensure that the process conditions do not pose any safety risks.
- If necessary, wear suitable personal protective equipment when working on the device.
- Depressurize and empty the device / piping, allow to cool and purge if necessary.

### ⚠ CAUTION

#### Risk of burns due to hot measuring media.

The device surface temperature may exceed 70 °C (158 °F), depending on the measuring medium temperature!

Before starting work on the device, make sure that it has cooled sufficiently.

### i NOTE

#### Loss of CE conformity!

For pressure equipment consisting of assemblies, CE conformity is only for devices in the factory-supplied state. Components should only be replaced by the manufacturer's service personnel or an authorized specialist workshop. Replacing components yourself will render the CE conformity invalid.

### 8.1 Spare parts

Repair and maintenance activities may only be performed by authorized customer service personnel.

When replacing or repairing individual components, use original spare parts.

### i NOTE

Spare parts can be ordered from ABB Service: Please contact Customer Center Service acc. to page 2 for nearest service location.

### 8.2 Cleaning

Soiling of the meter tube and the float will impair the measuring accuracy of the device. The necessary cleaning interval is dependent on the operating conditions and must be set individually.

The meter tube and the float must be removed in order to clean the device.

When cleaning the exterior of meters, make sure that the cleaning agent used does not corrode the housing surface and the seals.

To avoid static charge, a damp cloth must be used for cleaning.

#### 8.2.1 Disassembly of the meter tube

### i NOTE

#### Damage to the float!

Damage to the float due to incorrect disassembly.

Observe the following points when disassembling the meter tube and the float!

- The float is precision made. During assembly/disassembly, ensure that the guide ring and the measuring edge are not damaged. A damaged float causes inaccuracies in the measurement and can cause damage to the meter tube under certain circumstances.
- Ensure that the meter tube is not exposed to impacts or mechanical loads during disassembly.

FAM3220  
FAM3250

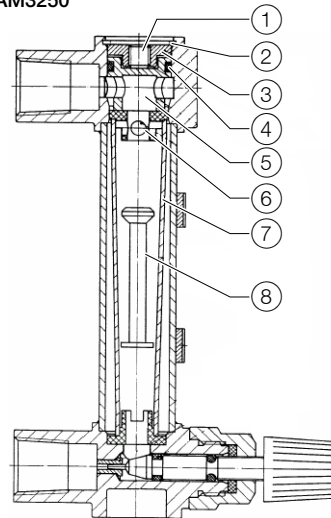

FAM3225  
FAM3255

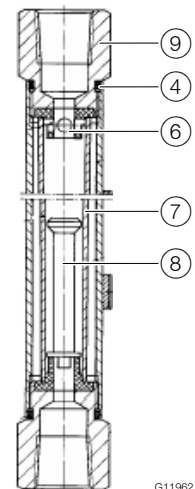

G11962

Fig. 7: Disassembly of the meter tube

To disassemble the meter tube and the float for maintenance purposes, proceed as follows:

#### FAM3220 / FAM3250

1. Loosen the threaded pin ①.
2. Remove the retaining ring ②.
3. Remove the pressure plate ③ and pressure piece ⑤.
4. Remove and clean the meter tube holder ⑥, meter tube ⑦, and float ⑧.
5. Check the O-ring ④ for damage and replace if necessary. Assembly is executed in the reverse sequence.

#### FAM3225 / FAM3255

1. Loosen the outlet fitting ⑨.
2. Remove and clean the meter tube holder ⑥, meter tube ⑦, and float ⑧.
3. Check the O-ring ④ for damage and replace if necessary. Assembly is executed in the reverse sequence.

### 8.3 Returning devices

Use the original packaging or a secure transport container of an appropriate type if you need to return the device for repair or recalibration purposes. Fill out the return form (see the Appendix) and include this with the device. According to the EU Directive governing hazardous materials, the owner of hazardous waste is responsible for its disposal or must observe the following regulations for shipping purposes: All devices delivered to ABB must be free from any hazardous materials (acids, alkalis, solvents, etc.).

Please contact Customer Center Service acc. to page 2 for nearest service location.

## 9 Recycling and disposal

### 9.1 Dismounting

#### WARNING

##### **Risk of injury due to process conditions.**

The process conditions, e.g. high pressures and temperatures, toxic and aggressive measuring media, can give rise to hazards when dismantling the device.

- If necessary, wear suitable personal protective equipment during disassembly.
- Before disassembly, ensure that the process conditions do not pose any safety risks.
- Depressurize and empty the device / piping, allow to cool and purge if necessary.

Bear the following points in mind when dismantling the device:

- Switch off the power supply.
- Disconnect electrical connections.
- Allow the device / piping to cool and depressurize and empty. Collect any escaping medium and dispose of it in accordance with environmental guidelines.
- Use appropriate tools to dismantle the device, taking the weight of the device into consideration.
- If the device is to be used at another location, the device should preferably be packaged in its original packing so that it cannot be damaged.
- See the information in chapter "Returning devices" on page 15.

## 9.2 Disposal

This product and its packaging are manufactured from materials that can be recycled by specialist recycling companies.

Bear the following points in mind when disposing of them:

- This product is not subject to WEEE Directive 2012/19/EU or relevant national laws (e.g. ElektroG in Germany).
- The product must be surrendered to a specialist recycling company. Do not use municipal garbage collection points. According to WEEE Directive 2012/19/EU, only products used in private applications may be disposed of at municipal garbage collection points.
- If it is not possible to dispose of old equipment properly, ABB Service can take receipt of and dispose of returns for a fee.

### **i** NOTE



Products that are marked with this symbol may not be disposed of through municipal garbage collection points.

## 10 Specifications

### 10.1 Material load

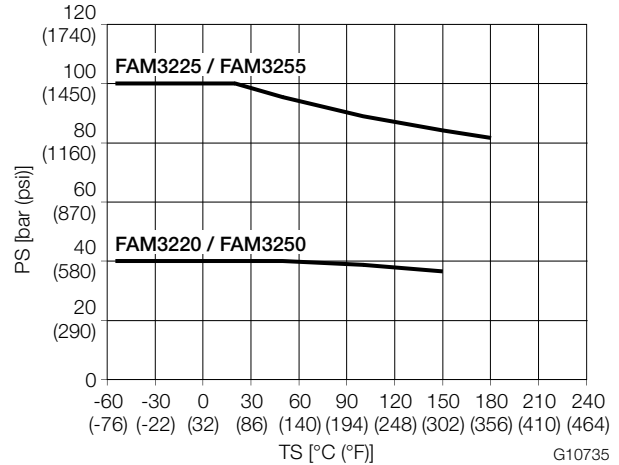

Fig. 8: PS: Pressure, TS: Temperature

### Maximum permissible operating pressure

The permissible operating pressure is dependent on the optional device equipment.

Model	Option	Max. permissible operating pressure
FAM3225 / FAM3255	Without	100 bar (1450.38 psi)
FAM3220 / FAM3250	With needle valve	40 bar (580.15 psi)
	With differential pressure regulator	14 bar (203.05 psi) (Standard, higher pressures available on request)

### Permissible measuring medium temperature

Permissible measuring medium temperature depending on gasket material.

Gasket materials	
O-ring / meter tube holder	T <sub>medium</sub> min / max
Viton A / PVDF	-20 ... 100 °C (-4 ... 212 °F)
Buna N / PVDF	-30 ... 100 °C (-22 ... 212 °F)
Kalrez / PTFE	-40 ... 180 °C (-40 ... 356 °F)
Viton A / PTFE	-20 ... 180 °C (-4 ... 356 °F)
Buna N / PTFE	-20 ... 100 °C (-4 ... 212 °F)
EPDM / PVDF	-50 ... 100 °C (-58 ... 212 °F)
Viton / none	-20 ... 180 °C (-4 ... 356 °F)
Buna N / none	-30 ... 100 °C (-22 ... 212 °F)
Kalrez / none	-40 ... 180 °C (-40 ... 356 °F)

### **i** NOTE

The permissible measuring medium temperature range is dependent on which gasket material is used. The details on the factory and name plate of the flowmeter must be strictly observed. Failure to comply with this information can result in destruction of the gasket and the flowmeter.



## 10.2 Measuring range table

### 10.2.1 Model FAM3220 / FAM3250 / FAM3225 / FAM3255, variable area and armored

The data listed applies to water at 20 °C (68 °F), 1 kg/dm<sup>3</sup> (62.43 lb/ft<sup>3</sup>), 1 mPas (1 cP) and to air at 0 °C (32 °F), 1013 mbar (14.7 psia). To set up devices for different measurement media or operating conditions please check the ABB Product Selection Assistant, available at [www.abb.com/flow](http://www.abb.com/flow).

Process connection <sup>1)</sup>	Maximum flowrate		V <sub>std</sub> <sup>2)</sup> [mPas (cp)]	P <sub>dif</sub> <sup>3)</sup> [bar (psi)]	P <sub>sta</sub> <sup>4)</sup> [bar (psi)]	D <sub>0</sub> <sup>5)</sup> [mbar (psi)]	Order code <sup>6)</sup>
	Water [l/h (USgal/h)]	Air [m <sup>3</sup> /h (scfh)]					
1/4"	1 (0.26)	35 (1.24)	4 (4)	0.7 (10.15)	1.0 (14.5)	8 (0.12)	01H
	1.6 (0.42)	54 (1.91)	4 (4)	0.7 (10.15)	1.0 (14.5)	8 (0.12)	02H
	2.5 (0.66)	100 (3.53)	6 (6)	0.7 (10.15)	1.0 (14.5)	8 (0.12)	03H
	4 (1.06)	160 (5.65)	6 (6)	0.7 (10.15)	1.0 (14.5)	8 (0.12)	04H
	6 (1.59)	230 (8.12)	18 (18)	0.7 (10.15)	1.0 (14.5)	8 (0.12)	05H
	10 (2.64)	350 (12.36)	18 (18)	0.7 (10.15)	1.0 (14.5)	8 (0.12)	06H
	16 (4.23)	540 (19.07)	18 (18)	0.7 (10.15)	1.0 (14.5)	8 (0.12)	07H
	25 (6.6)	850 (30.02)	18 (18)	0.7 (10.15)	1.0 (14.5)	9 (0.13)	08H
	40 (10.57)	1250 (44.14)	18 (18)	0.7 (10.15)	1.0 (14.5)	10.5 (0.15)	09H
	60 (15.85)	1900 (67.1)	18 (18)	0.7 (10.15)	1.0 (14.5)	12.5 (0.18)	10H
	100 (26.42)	3100 (109.48)	12 (12)	— <sup>7)</sup>	1.0 (14.5)	17.0 (0.25)	11H

1) Connection nominal size

2) V<sub>std</sub>: Maximum permissible viscosity without calibration.

3) P<sub>dif</sub>: Minimum required differential pressure for operation with a differential pressure regulator (FAM3220 / FAM3250 only).

4) P<sub>sta</sub>: Minimum required static pressure to prevent compression oscillations. For lower pressures, consult ABB.

5) Total pressure loss with stainless steel float at maximum flow.

6) Order code of the meter tube-float construction. See chapter **Fehler! Verweisquelle konnte nicht gefunden werden.** for further information.

7) Not available with differential pressure regulator.

## 10.2.2 Model FAM3225 / FAM3255, conical float and orifice plate

The data listed applies to water at 20 °C (68 °F), 1 kg/dm<sup>3</sup> (62.43 lb/ft<sup>3</sup>), 1 mPas (1 cP) and to air at 0 °C (32 °F), 1013 mbar (14.7 psia). To set up devices for different measurement media or operating conditions please check the ABB Product Selection Assistant, available at [www.abb.com/flow](http://www.abb.com/flow).

Process connection <sup>1)</sup>	Maximum flowrate		V <sub>std</sub> <sup>2)</sup> [mPas (cp)]	P <sub>dif</sub> <sup>3)</sup> [bar (psi)]	P <sub>sta</sub> <sup>4)</sup> [bar (psi)]	D <sub>p</sub> <sup>5)</sup> [mbar (psi)]	Order code <sup>6)</sup>
	Water [l/h (USgal/h)]	Air [m <sup>3</sup> /h (scfh)]					
3/8" or 1/2"	100 (26.42)	3200 (113.01)	8 (8)	4.0 (58.02)	0.3 (4.35)	60 (0.87)	20H
	160 (42.27)	5000 (176.57)	8 (8)	4.0 (58.02)	0.3 (4.35)	70 (1.02)	21H
	200 (52.83)	6000 (211.89)	8 (8)	4.0 (58.02)	0.3 (4.35)	80 (1.16)	22H
	250 (66.04)	8000 (282.52)	8 (8)	4.0 (58.02)	0.3 (4.35)	90 (1.31)	23H
	300 (79.25)	9000 (317.83)	8 (8)	4.0 (58.02)	0.3 (4.35)	160 (2.32)	24H
1/2"	400 (105.67)	12000 (423.78)	8 (8)	4.0 (58.02)	0.3 (4.35)	75 (1.09)	30H
	500 (132.09)	15000 (529.72)	8 (8)	4.0 (58.02)	0.3 (4.35)	85 (1.23)	31H
	600 (158.5)	18000 (635.66)	8 (8)	4.0 (58.02)	0.3 (4.35)	95 (1.38)	32H
	700 (184.92)	21000 (5547.61)	8 (8)	4.0 (58.02)	0.3 (4.35)	105 (1.53)	33H
	800 (211.34)	24000 (847.55)	8 (8)	4.0 (58.02)	0.3 (4.35)	130 (1.89)	34H
1"	800 (211.34)	23800 (840.49)	3 (3)	16 (232.06)	0.4 (5.8)	60 (0.87)	40H
	1000 (264.17)	29700 (1048.85)	3 (3)	16 (232.06)	0.4 (5.8)	62 (0.9)	41H
	1600 (422.68)	47600 (1680.98)	3 (3)	16 (232.06)	0.4 (5.8)	74 (1.07)	42H
	2000 (528.34)	59500 (2101.22)	3 (3)	16 (232.06)	0.4 (5.8)	85 (1.23)	43H
	2500 (660.43)	74400 (2627.41)	3 (3)	16 (232.06)	0.4 (5.8)	105 (1.52)	44H
	3000 (792.52)	89300 (3153.6)	3 (3)	16 (232.06)	0.4 (5.8)	130 (1.89)	45H

1) Connection nominal size

2) V<sub>std</sub>: Maximum permissible viscosity without calibration.

3) P<sub>sta</sub>: Minimum required static pressure for preventing compression oscillations. At low pressure, the use of the float damper is required.

4) P<sub>min</sub>: Minimum required static pressure in the device when using the optional float damper (Wendel).

5) Total pressure loss with stainless steel float at maximum flow.

6) Order code of the meter tube-float construction. See chapter **Fehler! Verweisquelle konnte nicht gefunden werden.** for further information.

## 11 Additional documents

### **i** NOTE

All documentation, declarations of conformity, and certificates are available in ABB's download area.

[www.abb.com/flow](http://www.abb.com/flow)

### Trademarks

® Buna-N is a registered trademark of DuPont Dow Elastomers.

® Kalrez and Kalrez Spectrum™ are registered trademarks of DuPont Performance Elastomers.

™ Viton is a DuPont de Nemours trademark

## 12 Appendix

### 12.1 Return form

#### Statement on the contamination of devices and components

Repair and / or maintenance work will only be performed on devices and components if a statement form has been completed and submitted.

Otherwise, the device / component returned may be rejected. This statement form may only be completed and signed by authorized specialist personnel employed by the operator.

#### Customer details:

Company: \_\_\_\_\_  
Address: \_\_\_\_\_  
Contact person: \_\_\_\_\_ Telephone: \_\_\_\_\_  
Fax: \_\_\_\_\_ E-Mail: \_\_\_\_\_

#### Device details:

Typ: \_\_\_\_\_ Serial no.: \_\_\_\_\_  
Reason for the return/description of the defect: \_\_\_\_\_  
\_\_\_\_\_  
\_\_\_\_\_

#### Was this device used in conjunction with substances which pose a threat or risk to health?

Yes  No

If yes, which type of contamination (please place an X next to the applicable items)?

Biological	<input type="checkbox"/>	Corrosive / irritating	<input type="checkbox"/>	Combustible (highly / extremely combustible)	<input type="checkbox"/>
Toxic	<input type="checkbox"/>	Explosiv	<input type="checkbox"/>	Other toxic substances	<input type="checkbox"/>
Radioactive	<input type="checkbox"/>				

Which substances have come into contact with the device?

1. \_\_\_\_\_  
2. \_\_\_\_\_  
3. \_\_\_\_\_

We hereby state that the devices / components shipped have been cleaned and are free from any dangerous or poisonous substances.

\_\_\_\_\_  
Town/city, date

\_\_\_\_\_  
Signature and company stamp

# Contact us

## **ABB Limited**

### **Measurement & Analytics**

Howard Road, St. Neots  
Cambridgeshire, PE19 8EU  
UK

Tel: +44 (0)870 600 6122

Fax: +44 (0)1480 213 339

Mail: [enquiries.mp.uk@gb.abb.com](mailto:enquiries.mp.uk@gb.abb.com)

## **ABB Inc.**

### **Measurement & Analytics**

125 E. County Line Road  
Warminster, PA 18974  
USA

Tel: +1 215 674 6000

Fax: +1 215 674 7183

## **ABB Automation Products GmbH**

### **Measurement & Analytics**

Dransfelder Str. 2  
37079 Goettingen  
Germany

Tel: +49 551 905-0

Fax: +49 551 905-777

Mail: [vertrieb.messtechnik-  
produkte@de.abb.com](mailto:vertrieb.messtechnik-produkte@de.abb.com)

[www.abb.com/flow](http://www.abb.com/flow)

## Note

We reserve the right to make technical changes or modify the contents of this document without prior notice.

With regard to purchase orders, the agreed particulars shall prevail. ABB does not accept any responsibility whatsoever for potential errors or possible lack of information in this document.

We reserve all rights in this document and in the subject matter and illustrations contained therein. Any reproduction, disclosure to third parties or utilization of its contents – in whole or in parts – is forbidden without prior written consent of ABB.

Copyright© 2017 ABB

All rights reserved

3KXF111300R4401

Translation of the original instruction

CI/FAM3200-EN Rev. B 07.2017