

ABB MEASUREMENT & ANALYTICS | DATA SHEET

Model 266MRT, 266GRT, 266RRT and 266ART

Differential, gauge and absolute pressure transmitters



Measurement made easy

Engineered solutions for all applications

Base accuracy

- 0.04 % of calibrated span

Proven sensor technology together with state-of-the-art digital technology

- Large turn down ratio of up to 60:1

Comprehensive selection of sensors

- Optimized performance and stability

Flexible configuration options

- Local configuration via keys on LCD indicator

New TTG (Through-The-Glass) key technology

- Enables quick and easy local configuration without the need to open the cover - even in environments with explosion protection

IEC 61508 certification

- For SIL2 (1001) and SIL3 (1002) applications

PED compliance to Sound Engineering Practice SEP

General description

The diaphragm seal models described in this data sheet are combined with transmitters 266XRT. One or two diaphragm seals can be connected to the transmitter via a capillary tube. The following models, which have different order codes, are available:

- 1 Model 266MRT for differential pressure may be designed with either two diaphragm seals of the same type and size or with one diaphragm seal (on the high pressure (H) or low pressure (L) side) plus a standard process flange with threaded connection. In this case, the threaded connection (1/4 – 18 NPT or 1/2 – 14 NPT using adapter) is for the liquid or dry leg on the side opposite the diaphragm seal.
- 2 Models 266GRT or 266ART / 266RRT for gauge pressure measurements with reference to atmospheric pressure or absolute pressure measurements with reference to vacuum are only equipped with one diaphragm seal. The table below lists the standard types of diaphragm seal that can be used together with transmitters 266XRT.

For specifications and details of the diaphragm seals, please refer to the corresponding diaphragm seal data sheet DS/S26.

Differential pressure transmitters with two diaphragm seals:

In all cases, the specifications below only apply to identical seal designs on both sides.

Diaphragm seal model	Diaphragm seal type	Seal diaphragm size (thickness)	Mnemonic symbol
S26WA S26WE	Wafer diaphragm seal (ASME and EN standards)	1.5 in. / DN 40	P1.5
		2 in. / DN 50	P2
		3 in. / DN 80	P3
		1.5 in. / DN 40 (thin)	F1.5
		2 in. / DN 50 (thin)	F2
S26FA S26FE S26RA S26RE	Flush diaphragm flanged seal (ASME and EN standards; fixed and rotating flange)	3 in. / DN 80 (thin)	F3
		2 in. / DN 50	P2
		3 in. / DN 80	P3
		4 in. / DN 100	P3
		2 in. / DN 50 (thin)	F2
S26RR	Flush diaphragm flanged seal (ring joint in acc. with ASME standards; rotating flange)	3 in. / DN 80 (thin)	F3
		4 in. / DN 100 (thin)	F3
		2 in. / DN 50	E2
S26RJ	Flush diaphragm flanged seal (JIS standards; rotating flange only)	3 in. / DN 80	E3
		4 in. / DN 100	P3
		A 50	P2
S26RR	Flush diaphragm flanged seal (ring joint in acc. with ASME standards; rotating flange)	A 80	P3
		A 100	P3
		1.5 in.	P1.5
S26CN	Flanged diaphragm seal, "chemical tee"	2 in.	P2
S26TT	Off-line diaphragm seal; threaded connection	3 in.	P3
S26MA, S26ME	Off-line diaphragm seal; flange connection (ASME and EN standards)	2 1/2 in.	T 2.5
		3 in.	P3
S26SS	Diaphragm seal with compression nut Triclamp Cherry Burrel Aseptic diaphragm seal for sanitary applications	2 1/2 in.	T 2.5
		1 1/2 in.	K 1.5
		2 in. / F50	S2
		3 in. / F80	S3
S26VN	Diaphragm seal for weld-on saddle flange or weld-in sleeve flange	4 in.	S3
S26UN	Threaded diaphragm seal for flange sleeve or welding spud	2 1/2 in.	P1.5
S26BN	Button diaphragm seal	1 1/2 in.	Z1.5
S26PN	Flanged diaphragm seal for urea service	1 in.	B1
		1 1/2 in.	U1.5
		2 1/2 in.	U2.5

Functional specification

Measuring range limits and span limits

Sensor Code	Measuring range upper limit (URL)	Measuring range lower limit (LRL)				Minimum measuring span	
		266MRT Differential pressure	266GRT Gauge pressure	266RRT Absolute pressure	266ART Absolute pressure	266MRT 266GRT	266RRT 266ART
C	6 kPa	-6 kPa	-6 kPa		0.07 kPa abs.	0.6 kPa	1.2 kPa abs (Δ)
	60 mbar	-60 mbar	-60 mbar		0.7 mbar abs.	6 mbar	12 mbar abs (Δ)
	24 inH2O	-24 inH2O	-24 inH2O		0.5 mm Hg	2.41 inH2O	9 mm Hg (Δ)
F	40 kPa	-40 kPa	-40 kPa	0.07 kPa abs (§)	0.07 kPa abs.	0.67 kPa	2 kPa abs.
	400 mbar	-400 mbar	-400 mbar	0.7 mbar abs (§)	0.7 mbar abs.	6.7 mbar	20 mbar abs.
	160 inH2O	-160 inH2O	-160 inH2O	0.5 mm Hg (§)	0.5 mm Hg	2.67 inH2O	15 mm Hg
L	250 kPa	-250 kPa	0.07 kPa abs (§)	0.07 kPa abs (§)	0.07 kPa abs (§)	4.17 kPa	12.5 kPa abs.
	2500 mbar	-2500 mbar	0.7 mbar abs (§)	0.7 mbar abs (§)	0.7 mbar abs (§)	41.67 mbar	125 mbar abs.
	1000 inH2O	-1000 inH2O	0.5 mm Hg (§)	0.5 mm Hg (§)	0.5 mm Hg (§)	16.73 inH2O	93.8 mm Hg
D	1000 kPa		0.07 kPa abs (§)		0.07 kPa abs (§)	16.7 kPa	50 kPa abs (Δ)
	10 bar		0.7 mbar abs (§)		0.7 mbar abs (§)	167 mbar	500 mbar abs (Δ)
	145 psi		0.5 mm Hg (§)		0.5 mm Hg (§)	2.42 psi	7.25 psia (Δ)
N	2000 kPa			0.07 kPa abs (§)		33.3 kPa	100 kPa abs (#)
	20 bar	-2000 kPa -20 bar -290 psi		0.7 mbar abs (§)		333 mbar	1 bar abs (#)
	290 psi			0.5 mm Hg (§)		4.83 psi	14.5 psia (#)
U	3000 kPa		0.07 kPa abs (§)		0.07 kPa abs (§)	50 kPa	150 kPa abs (Δ)
	30 bar		0.7 mbar abs (§)		0.7 mbar abs (§)	500 mbar	1.5 bar abs (Δ)
	450 psi		0.5 mm Hg (§)		0.5 mm Hg (§)	7.25 psi	21.7 psia (Δ)
R	10000 kPa		0.07 kPa abs (§)		0.07 kPa abs (§)	167 kPa	500 kPa abs (Δ)
	100 bar	-10000 kPa -100 bar -1450 psi	0.7 mbar abs (§)		0.7 mbar abs (§)	1.67 bar	5 bar abs (Δ)
	1450 psi		0.5 mm Hg (§)		0.5 mm Hg (§)	24.17 psi	72.6 psia (Δ)
V	60000 kPa		0.07 kPa abs (§)			1000 kPa	
	600 bar		0.7 mbar abs (§)			10 bar	
	8700 psi		0.5 mm Hg (§)			145 psi	

(§) Measuring range lower limit 0.135 kPa abs, 1.35 mbar abs, 1 mm Hg for fluorocarbon (Galden).

(Δ) For 266ART only

(#) For 266RRT only

Span limits

Maximum span = URL
(for differential pressure transmitter, can be adjusted up to \pm URL (TD = 0.5) within the measuring range limits).

Important

To optimize measuring accuracy, it is recommended that you select the transmitter sensor code with the lowest turn down ratio.

Zero position suppression and elevation

The zero position and span can be set to any value within the measuring range limits listed in the table if:

- Set span \geq minimum span

Damping

Configurable time constant between 0 and 60 s.
This is in addition to the sensor response time.

Warm-up time

Ready for operation as per specifications in less than 10 s with minimum damping.

Insulation resistance

>100 M Ω at 500 V DC (between terminals and ground).

Operating limits

SEE ALSO DATA SHEET DS/S26 FOR INFORMATION ON OTHER POSSIBLE RESTRICTIONS BASED ON DIAPHRAGM SEAL VERSIONS.

Pressure limits

Overpressure limits

Without damage to the transmitter

Models 266MRT and 266RRT	Filling fluid	Overpressure limits
Sensors C to R	Silicone oil	0.07 kPa abs., 0.7 mbar abs., 0.5 mm Hg and 16 MPa, 160 bar, 2,320 psi, or 25 MPa, 250 bar, 3,625 psi, or 41 MPa, 410 bar, 5,945 psi depending on code variant selected
Sensors C to R	Fluorocarbon (Galden)	17.5 kPa abs., 175 mbar abs., 131 mm Hg and 16 MPa, 160 bar, 2,320 psi, or 25 MPa, 250 bar, 3,625 psi, or 41 MPa, 410 bar, 5,945 psi depending on code variant selected

Models 266GRT and 266ART	Filling fluid	Overpressure limits
Sensor C, F	-	0.07 kPa abs., 0.7 mbar abs., 0.5 mm Hg and 1 MPa, 10 bar, 145 psi
Sensor L	Silicone oil	0.07 kPa abs., 0.7 mbar abs., 0.5 mm Hg and 3 MPa, 30 bar, 435 psi
Sensor D	Silicone oil	0.07 kPa abs., 0.7 mbar abs., 0.5 mm Hg and 6 MPa, 60 bar, 870 psi
Sensor U	Silicone oil	0.07 kPa abs., 0.7 mbar abs., 0.5 mm Hg and 6 MPa, 60 bar, 870 psi
Sensor R	Silicone oil	0.07 kPa abs., 0.7 mbar abs., 0.5 mm Hg and 30 MPa, 300 bar, 4350 psi
Sensor V	Silicone oil	0.07 kPa abs., 0.7 mbar abs., 0.5 mm Hg and 90 MPa, 900 bar, 13050 psi
Sensor L	Fluorocarbon (Galden)	0.135 kPa abs., 1.35 mbar abs., 1 mm Hg and 3 MPa, 30 bar, 435 psi
Sensor D	Fluorocarbon (Galden)	0.135 kPa abs., 1.35 mbar abs., 1 mm Hg and 6 MPa, 60 bar, 870 psi
Sensor U	Fluorocarbon (Galden)	0.135 kPa abs., 1.35 mbar abs., 1 mm Hg and 6 MPa, 60 bar, 870 psi
Sensor R	Fluorocarbon (Galden)	0.135 kPa abs., 1.35 mbar abs., 1 mm Hg and 30 MPa, 300 bar, 4350 psi
Sensor V	Fluorocarbon (Galden)	0.135 kPa abs., 1.35 mbar abs., 1 mm Hg and 90 MPa, 900 bar, 13050 psi

Static pressure limits

Transmitters for differential pressure, models 266MRT, can operate within the specifications with the following limit values.

Sensors	Filling fluid	Static pressure limits
Sensors C to R	Silicone oil	3.5 kPa abs., 35 mbar abs., 0.5 psia and 16 MPa, 160 bar, 2,320 psi, or 25 MPa, 250 bar, 3,625 psi, or 41 MPa, 410 bar, 5,945 psi depending on code variant selected
Sensors C to R	Fluorocarbon (Galden)	17.5 kPa abs., 175 mbar abs., 131 mm Hg and 16 MPa, 160 bar, 2,320 psi, or 25 MPa, 250 bar, 3,625 psi, or 41 MPa, 410 bar, 5,945 psi depending on code variant selected

The overpressure limits and upper static pressure limits can be lowered by means of the nominal pressure rating of the diaphragm seal flange; see diaphragm seal data sheet DS/S26.

Test pressure

The transmitters can withstand a pressure test with the following line pressure without leaking:

Model	Test pressure
266MRT	1.5 x nominal pressure (static pressure limit) simultaneously on both sides 1
266RRT	1 x nominal pressure (static pressure limit) 1
266GRT / 266ART	Overpressure limits of sensor ¹

¹ Or double the value of the pressure sensor flange pressure stage, depending on which value is less.

Meets hydrostatic test requirements of ANSI/ISA-S 82.03.

Temperature limits °C (°F)

Environment

This is the operating temperature.

Models 266MRT, 266RRT	Ambient temperature limits
Silicone oil for sensors C to R	-40 ... 85 °C (-40 ... 185 °F)
Fluorocarbon (Galden) for sensors C to R	-40 ... 85 °C (-40 ... 185 °F)

Models 266GRT, 266ART	Ambient temperature limits
Silicone oil for sensor	-40 ... 85 °C (-40 ... 185 °F)
Inert (Galden) for sensor	-40 ... 85 °C (-40 ... 185 °F)
White oil for sensor	-6 ... 85 °C (21 ... 185 °F)

Models 266XRT	Ambient temperature limits
Integrated LCD display	-40 ... 85 °C (-40 ... 185 °F)

Below -20 °C (-4 °F) and above 70 °C (158 °F), it may no longer be possible to read the LCD display clearly.

Important

For applications in explosive environments, the temperature range specified on the certificate / approval applies dependent upon the degree of protection sought.

Process

Models 266MRT (side without diaphragm seal)	Process temperature limits
Silicone oil for sensors C to R	-40 ... 121 °C (-40 ... 250 °F) 1
Fluorocarbon (Galden) for sensors C to R	-40 ... 121 °C (-40 ... 250 °F) 2
Viton gasket	-20 ... 121 °C (-4 ... 250 °F)
PTFE gasket	-20 ... 85 °C (-4 ... 185 °F)

1 85 °C (185 °F) for applications under 10 kPa, 100 mbar abs., 1.45 psia up to 3.5 kPa abs., 35 mbar abs., 26 mm Hg
2 85 °C (185 °F) for applications below atmospheric pressure up to 17.5 kPa abs., 175 mbar abs., 131 mm Hg

The table below contains the specifications for diaphragm seal filling fluids when used in transmitters with (a) diaphragm seal(s).

Filling fluid (application)	Process temperature and pressure limits			
	Tmax °C (°F) @ Pabs > than	Pmin mbar abs (mm Hg)	Tmax °C (°F) @ Pmin	Tmin °C (°F)
Silicone oil PMX 200 10 cSt	250 (480) @ 385 mbar	0,7 (0,5)	130 (266)	-40 (-40)
Silicone oil Baysilone PD5 5 cSt	250 (480) @ 900 mbar	0,7 (0,5)	45 (123)	-85 (-121)
Fluorocarbon Galden G5 (oxygen applications)	160 (320) @ 1 bar	2,1 (1,52)	60 (140)	-20 (-4)
Fluorocarbon Halocarbon 4.2 (oxygen applications)	180 (356) @ 425 mbar	4 (3)	70 (158)	-20 (-4)
Silicone polymer Syltherm XLT (cryogenic applications)	110 (230) @ 118 mbar	2,1 (1,52)	20 (68)	-100 (-148)
Silicone oil DC 704 (high-temperature applications)	375 (707) @ 1 bar	0,7 (0,5)	220 (328)	-10 (14)
Vegetable oil Neobee M-20 (food and beverage, sanitary applications) with FDA approval	200 (390) @ 1 bar	10 (7,2)	20 (68)	-18 (0)
Mineral oil Esso Marcol 122 (food and beverage, sanitary applications) with FDA approval	250 (480) @ 630 mbar	0,7 (0,5)	110 (230)	-6 (21)
Glycerin water 70 % (food and beverage, sanitary applications) with FDA approval	93 (200) @ 1 bar	1000 (760)	93 (200)	-7 (-20)

...Operating limits

...Temperature limits °C (°F)

Flushing ring gasket material	Process limits		
	Pressure (max.)	Temperature	P x T
Garlock	6.9 MPa, 69 bar, 1,000 psi	-73 ... 204 °C (-100 ... 400 °F)	250,000 (°F x psi)
Graphite	2.5 MPa, 25 bar, 362 psi	-100 ... 380 °C (-148 ... 716 °F)	
PTFE	6 MPa, 60 bar, 870 psi	-100 ... 250 °C (-148 ... 482 °F)	

Storage

Models 266XRT	Storage temperature range
Silicone oil	-50 ... 85 °C (-58 ... 185 °F)
Integral LCD display	-40 ... 85 °C (-40 ... 185 °F)

Limits for environmental effects

Electromagnetic compatibility (EMC)

Meets requirements of EN 61326 and Namur NE-21
Overvoltage strength (with surge protection): 4 kV
(in acc. with IEC 1000-4-5 EN 61000-4-5).

Pressure Equipment Directive (PED)

Comply with 2014/68/UE to standard ANSI/ISA
61010-1:2012 following Sound Engineering Practice (SEP).

Humidity

Relative humidity: Up to 100 %.
Condensation, icing: Permissible.

Vibration resistance

Acceleration up to 2 g at frequencies of up to 1000 Hz
(according to IEC 60068-2-6).
Acceleration limited to 1 g for housing out of stainless
steel.

Shock resistance

Acceleration: 50 g
Duration: 11 ms
(according to IEC 60068-2-27).

IP rating

In accordance with EN 60529, JIS C0920
The transmitter is dust and sand proof and protected
against immersion effects.

- IP 67, IP 68 on request, NEMA 4X
- IP 65 (devices with Harting Han plug connector)
- IP 66 (devices with barrel housing made from aluminum
or stainless steel housing)

Hazardous atmospheres

With or without integral LCD display

Type of protection "Intrinsic safety":

Approval in accordance with ATEX Europa (code E1) and IEC Ex (code E8)
II 1 G Ex ia IIC T6/T5/T4 and II 1/2 G Ex ia IIC T6/T5/T4; IP67.
II 1 D Ex iaD 20 T85°C and II 1/2 D Ex iaD 21 T85 °C; IP67
NEPSI China (Code EY)
Ex ia IIC T4~T6, DIP A20TA, T4~T6.

Type of protection "Flameproof (enclosure)":

Approval in accordance with ATEX Europa (code E2) and IEC Ex (code E9)
II 1/2 G Ex d IIC T6 and
II 1/2 D Ex tD A21 T85 °C (-50 °C ≤ Ta ≤ +75 °C); IP67.
NEPSI China (Code EZ)
Ex d IIC T6, DIP A21TA, T6.

Type of protection "nL":

ATEX Europa (code E3) and IEC Ex (code ER)
Declaration of Conformity
II 3 G Ex nL IIC T6/T5/T4 and II 3 D Ex tD A22 T85 °C; IP67.
NEPSI China (code EY) Declaration of conformity
Ex nL IIC T4~T6, DIP A22TA, T6.

FM approvals for USA (code E6) and FM approvals for Canada (code E4):

- Explosionproof (US): Class I, Div. 1, Groups A, B, C, D
 - Explosionproof (Canada): Class I, Div. 1, Groups B, C, D
 - Dust ignitionproof : Class II, Div. 1, Groups E, F, G
 - Suitable for: Class II, Div. 2, Groups F, G; Class III, Div.1, 2
 - Nonincendive: Class I, Div. 2, Groups A, B, C, D
 - Intrinsically safe: Class I, II, III, Div. 1, Groups A, B, C, D, E, F, G
- Class I, Zone 0 AEx ia IIC T6/T4, Zone 0 (FM US)
Class I, Zone 0 Ex ia IIC T6/T4, Zone 0 (FM Canada)

ATEX combined (code EW = E1 + E2 + E3), (code E7 = E1 + E2)

ATEX combined and FM approvals (code EN = EW + E4 + E6)

Combined FM approvals for USA and Canada

- Intrinsic safety (Code EA)
- Flameproof (enclosure) (Code EB)
- Non-incendive (Code EC)

IEC combined (code EH = E8 + E9), (code EI = E8 + E9 + ER)

NEPSI combined (code EP = EY + EZ), (code EQ = EY + EZ + ES)

- EAC-Ex (GOST) Russia, Kazakhstan, Belarus,), based on ATEX
- Inmetro (Brazil), based on ATEX

The permissible ambient temperature ranges (within the
limits of 50 to 85 °C) are specified in the type examination
certificates dependent upon the temperature class.

Specification – electrical data and options

HART® digital communication and 4 ... 20 mA output

Power supply

The transmitter operates from 10.5 ... 42 V DC with no load and is protected against reversed polarity (additional loads enable operation above 42 V DC).

During use in Ex ia zones and in other intrinsically safe applications, the power supply must not exceed 30 V DC.

Minimum operating voltage

12.3 V DC	Device with the option "S2 – overvoltage protection"
10.8 V DC	Devices with the option "YE – NE21 conformity"

Ripple

Max. 20 mV over a 250 Ω load as per HART specifications.

Load limitations

Total loop resistance at 4 ... 20 mA and HART:

$$R \text{ (k}\Omega\text{)} = \frac{\text{Voltage supply} - \text{Minimum operating voltage (V DC)}}{22 \text{ mA}}$$

A minimum resistance of 250 Ω is required for HART communication.

Surge protection (optional)

Up to 4 kV

- Voltage: 1.2 μs rise time / 50 μs delay time at half value
- Current: 8 μs rise time / 20 μs delay time at half value

Output signal

Two-wire output 4 – 20 mA, selectable by the operator: linear or square root output signal, characteristic curve with the exponents 3/2 or 5/2, square root for bidirectional flow, linearization table with 22 points (i.e. for level measurements in lateral, cylindrical containers and spherical containers).

The HART communication provides the digital process variables which are superimposed on the 4 to 20 mA signal (protocol in accordance with Bell 202 FSK standard).

Output current limits (according to NAMUR standard)

Overload condition

- Lower limit: 3.8 mA (configurable from 3.8 ... 4 mA)
- Upper limit: 20.5 mA (configurable from 20 ... 21 mA)

Alarm current

- Minimum alarm current: 3.6 mA (configurable from 3.6 ... 4 mA)
- Maximum alarm current: 21 mA (configurable from 20 ... 22 mA)

Default setting: High Alarm Current

HART protocol

HART revision 7 (standard, as default)

HART revision 5 (optional, on request)

Output current limits (in accordance with NAMUR standard)

Overload condition

- Lower limit: 3.8 mA (configurable from 3.8 – 4 mA)
- Upper limit: 20.5 mA (configurable from 20 – 21 mA)

Alarm current

Adjustment range

Minimum alarm current (low alarm current)	3.6 mA (configurable from 3.6 – 4 mA)
Maximum alarm current (high alarm current)	21 mA (configurable from 20 – 23 mA)
Maximum alarm current (high alarm current) for devices with "HART SIL – functional safety"	Limited to maximum 22 mA! (From electronic version 7.1.15)

Standard setting: high alarm current

Process diagnostics (PILD)

Plugged impulse line detection (PILD) generates a warning via HART communication. The device can also be configured to drive the analog output signal to the "alarm current".

FOUNDATION Fieldbus™ output

Model

Link Active Scheduler (LAS) capability implemented.
 Manufacturer code: 000320 (hex)
 Device type code: 0007 (hex)

Power supply

The transmitter operates from 9 ... 32 V DC, regardless of polarity, with or without surge protection.
 During use in EEx ia zones, the power supply must not exceed 24 V DC (entity certification) or 17.5 V DC (FISCO certification) according to FF-816.

Current consumption

Operating (quiescent): 15 mA
 Fault current limit value: 20 mA max.

Output signal

Physical layer in accordance with IEC 11582 / EN 611582; transmission using Manchester II modulation at 31.25 kbit/s.

Function blocks/execution period

- 3 enhanced analog input blocks / 25 ms max. (each)
- 1 extended PID block / 40 ms max.
- 1 standard arithmetic block / 25 ms
- 1 standard input selector block / 25 ms
- 1 standard control selector block / 25 ms
- 1 standard signal characterization block / 25 ms
- 1 standard integrator / totalizer block / 25 ms

Additional blocks

- 1 enhanced resource block
- 1 manufacturer-specific pressure with calibration transducer block
- 1 manufacturer-specific advanced diagnostics transducer block
- 1 manufacturer-specific local display transducer block

Number of link objects

35

Number of VCRs

35

Output interface

FOUNDATION fieldbus digital communication protocol in accordance with standard H1; complies with specification V. 1.7.
 FF registration in progress.

Transmitter interference mode

The output signal is "frozen" at the last valid value in the event of significant transmitter interference, once this interference is detected by the self-diagnostics function (which also displays error states).
 In the event of electronics failures or short circuits, the transmitter consumption is electronically limited to a defined value (approx. 20 mA) in order to ensure network safety.

...Specification – electrical data and options

PROFIBUS PA output

Model

Pressure transmitter, compliant with Profile 3.0.1
ID number: 3450 (hex)

Power supply

The transmitter operates from 9 ... 32 V DC, regardless of polarity, with or without surge protection.

The power supply must not exceed 17.5 V DC when used in EEx ia zones.

Intrinsically safe installation in accordance with FISCO model.

Current consumption

Operating (quiescent): 15 mA

Fault current limit value: 20 mA max.

Output signal

Physical layer in accordance with IEC 1158-2 / EN 61158-2; transmission using Manchester II modulation at 31.25 kbit/s

Output interface

PROFIBUS PA communication according to PROFIBUS DP 50170 Part 2 / DIN 19245 Parts 1-3.

Output cycle time

25 ms

Data blocks

1 "physical block"

3 "analog input" blocks

1 "pressure transducer block" with calibration

1 "transducer block" for local display

LCD display



M10142

Figure 1 LCD display (example)

Integral LCD display (code L1)

Wide screen LCD display, 128 x 64 pixel, 52.5 x 27.2 mm (2.06 x 1.07 in.), dot matrix, multilingual.

Four buttons for device configuration and management.

Easy setup for quick commissioning.

Customized visualizations which the user can select.

Total value and actual value flow indication.

The display can also be used to show static pressure, sensor temperature, and diagnosis notice, as well as make configuration settings.

Integral LCD display with TTG–(Through–The–Glass) operation (code L5)

As with the integral LCD display above, but featuring an innovative TTG (Through–The–Glass) button technology which can be used to activate the device's configuration and management menus without having to remove the transmitter housing cover.

The TTG (Through–The–Glass) buttons are protected against accidental activation.

Specification - measuring accuracy

Measured with reference conditions acc. to IEC 60770 environment

Ambient temperature 20 °C (68 °F), rel. humidity 65 %, atmospheric pressure 1,013 hPa (1,013 mbar), position of measuring cell (separation diaphragm areas) vertical, measuring span based on zero position, separation diaphragms made from stainless steel AISI 316 L or Hastelloy, silicone oil filling fluid, HART digital trim values equal to 4 and 20 mA span end points, linear characteristic.

Unless otherwise stated, errors are specified as a % of the span value.

Some measuring accuracy levels relating to the upper measuring range limit (URL) are affected by the current turn down (TD); i.e., the ratio of the upper measuring range limit to the set span.

FOR OPTIMUM MEASURING ACCURACY, IT IS RECOMMENDED THAT YOU SELECT THE TRANSMITTER SENSOR CODE WHICH WILL PROVIDE THE LOWEST TD VALUE.

Measuring error

% of calibrated span, consisting of terminal-based non-linearity, hysteresis, and non-repeatability.

In the case of fieldbus devices, SPAN refers to the analog input function block output scale range.

Model	Sensor	For TD range	Measuring error
266MRT with DF	F to R	From 1:1 to 10:1	± 0.04 %
Mnemonic P3, F3, E3, S3, F2	F to R	From 10:1 to 60:1	± (0.04 + 0.005 x TD - 0.05) %
	C	From 1:1 to 5:1	± 0.04 %
	C	From 5:1 to 10:1	± (0.008 x TD) %
266MRT with DF	F to R	From 1:1 to 10:1	± 0.065 %
Mnemonic different from above	F to R	From 10:1 to 60:1	± (0.0065 x TD) %
	C	From 1:1 to 5:1	± 0.065 %
	C	From 5:1 to 10:1	± (0.013 x TD) %

DF = Diaphragm seal

Model	Sensor	For TD range	Measuring error
266RRT with DF	F, L, N	From 1:1 to 10:1	± 0.04 %
Mnemonic P3, F3, E3, S3, F2	F, L, N	From 1:1 to 20:1	± (0.04 + 0.005 x TD - 0.05) %
266RRT with DF	F, L, N	From 1:1 to 10:1	± 0.065 %
Mnemonic different from above	F, L, N	From 1:1 to 20:1	± (0.0065 x TD) %

Model	Sensor	For TD range	Measuring error
266GRT with DF	F to V	From 1:1 to 10:1	± 0.04 %
Mnemonic P3, F3, E3, S3, F2	F to V	From 10:1 to 60:1	± (0.04 + 0.005 x TD - 0.05) %
	C	From 1:1 to 5:1	± 0.04 %
	C	From 5:1 to 10:1	± (0.008 x TD) %
266GRT with DF	F to V	From 1:1 to 10:1	± 0.065 %
Mnemonic different from above	F to V	From 10:1 to 60:1	± (0.0065 x TD) %
	C	From 1:1 to 5:1	± 0.065 %
	C	From 5:1 to 10:1	± (0.013 x TD) %

Model	Sensor	For TD range	Measuring error
266ART with DF	F to R	From 1:1 to 10:1	± 0.04 %
Mnemonic P3, F3, E3, S3, F2	F to R	From 10:1 to 20:1	± (0.04 + 0.005 x TD - 0.05) %
	C	From 1:1 to 5:1	± 0.04 %
266ART with DF	F to R	From 1:1 to 10:1	± 0.065 %
Mnemonic different from above	F to R	From 10:1 to 20:1	± (0.0065 x TD) %
	C	From 1:1 to 5:1	± 0.065 %

Model	Pabs sensor (second sensor for 266MRT)	Measuring range
266MRT	C to R	80 kPa, 800 mbar, 321 in H2O

...Specification – measuring accuracy

Ambient temperature

Transmitter effect per 20 K change within the limits of -40 to 85 °C

(Transmitter effect per 36 °F change within the limits of -40 to 185 °F):

Model	Sensor	For TD range	
266MRT	C to R	10:1	± (0.03 % URL + 0.045 % span)
266RRT	F, L, N	10:1	± (0.05 % URL + 0.08 % span)
266GRT	C and F	10:1	± (0.06 % URL + 0.09 % span)
266GRT	L to V	10:1	± (0.03 % URL + 0.045 % span)
266ART	C and F	5:1 (C) 10:1 (F)	± (0.06 % URL + 0.09 % span)
266ART	L to R	10:1	± (0.03 % URL + 0.045 % span)

Model 266MRT / Absolute pressure sensor

For the entire temperature range of 125 K, within the limits of -40 °C to 85 °C:

- **zero signal**

For sensors C to R:

40 kPa, 400 mbar, 160 in H₂O

(absolute pressure sensor 41MPa, 410 bar, 5,945 psi)

- **measuring span**

For sensors C to R:

0.3 MPa, 3 bar, 43.5 psi

(absolute pressure sensor 41 MPa, 410 bar, 5,945 psi)

SEE DATA SHEET DS/S26 FOR ADDITIONAL TEMPERATURE EFFECTS ON THE DIAPHRAGM SEALS:

The total temperature effect can be defined as the combined influence of the factors referred to above on the transmitter plus the influence of the diaphragm seal, dependent upon the operating temperature.

Static pressure

Model 266MRT with diaphragm seal(s)

(zero signal errors may be calibrated out at operating pressure)

Measuring range	Sensors C, F, L, N	Sensor R
Zero signal error	Up to 100 bar: 0.05 % URL	Up to 100 bar: 0.1 % URL
	> 100 bar: 0.05 % URL/100 bar	> 100 bar: 0.1 % URL/100 bar
Span error	Up to 100 bar: 0.05 % span	Up to 100 bar: 0.1 % span
	> 100 bar: 0.05 % span/100 bar	> 100 bar: 0.1 % span/100 bar

Power supply

Within the limit values for the voltage / load, the total influence is less than 0.005 % of the upper measuring range limit per volt.

Load

Within the load / voltage limits, the total influence is negligible.

Electromagnetic field

Meets all requirements of EN 61326 and NAMUR NE-21.

Common-mode interference

No influence from 100 V rms @ 50 Hz, or 50 V DC

Specification – physical

(Please refer to the order information to check the availability of different versions of the relevant model)

Materials

Model 266MRT only – Side without diaphragm seal

Process separation diaphragms 1

Stainless steel (AISI 316L - 1.4435)

Hastelloy C276;

Monel 400; tantalum

A diaphragm seal with the required diaphragm material can be selected in this case too (as with the high pressure side).

Process flanges, adapters, screw plugs, and vent / drain valves 1

Stainless steel AISI 316L; Hastelloy C276; Monel 400

Screws and nuts

Screws made from stainless steel AISI 316, class A4-70 as per UNI 7323 (ISO 3506) in compliance with NACE MR0175 Class II.

Gaskets 1

Viton (FPM); Buna (NBR); EPDM; PTFE; graphite

Models 266MRT, 266RRT, 266GRT, 266ART

Seal diaphragm material (high pressure side) 1

Stainless steel AISI 316 L; Hastelloy C-276;

Hastelloy C-2000; Inconel 625; tantalum;

stainless steel AISI 316 L or Hastelloy C-276 with non-stick coating;

stainless steel AISI 316 L with anti-corrosion coating;

stainless steel AISI 316 L, gold-plated;

super duplex stainless steel (UNS S32750 in acc. with ASTM SA479);

Diaflex (AISI with anti-abrasion treatment)

Diaphragm seal extension material 1

Stainless steel AISI 316 L (also for Diaflex-coated and gold-plated diaphragm);

Hastelloy C-276; stainless steel AISI 316 L or Hastelloy C-276 with the same coating as the diaphragm.

Diaphragm seal filling fluid

Silicone oil DC200; silicone oil DC704; fluorocarbon (Galden);

Fluorocarbon Halocarbon 4.2; silicone polymer Syltherm XLT;

low-viscosity silicone oil Baysilone PD5; glycerin water; vegetable oil Neobee M-20; mineral oil Esso Marcol 122

Sensor filling fluid

Silicone oil, fluorocarbon (Galden)

Sensor housing

Stainless steel (AISI 316L)

Electronics housing and cover

Aluminum alloy (copper content $\leq 0.3\%$) with baked epoxy finish (color: RAL 9002); stainless steel AISI 316L.

O-ring cover

Buna N (Perbunan)

Mounting bracket 2

Galvanized C steel with chromium passivation; stainless steel AISI 316.

Operating element for local zero point, measuring span, and write protection settings

Non-intrusive design (removable) made of glass fiber reinforced polypropylene oxide.

Plates

- Transmitter name plate: Stainless steel AISI 316 fastened to the electronics housing.
- Certification plate and optional measuring point tag plate / settings plate: Adhesive, fastened to the electronics housing or stainless steel AISI 316L fastened to the electronics housing with rivets or screws.
- Optional tag plate with customer data: Stainless steel AISI 316L.

The metal plates are laser engraved, the adhesive signs thermo-printed.

For stainless steel housings AISI 316L, the order option I2 or I3 must be selected for plates made from stainless steel AISI 316.

1 Transmitter parts that come into contact with fluid

2 U-bolt material: stainless steel AISI 400;

screw material: high-strength alloy steel or stainless steel AISI 316

...Specification – physical

Calibration

Standard:

- 0 to measuring range upper limit, for ambient temperature and atmospheric pressure

Optional:

- To specified measuring span

Optional extras

Mounting bracket

For vertical and horizontal 60 mm (2 in.) pipes or wall mounting

LCD display

Can be rotated in 90° increments into 4 positions

Additional tag plates

Code I2: For measuring point tag (up to 30 characters) and calibration specifications (up to 30 characters: lower and upper value plus unit), attached to transmitter housing.

Code I1: For customer data (4 lines with 30 characters each), attached to transmitter housing with wire.

Overvoltage protection

- Code S2

Cleaning stage for oxygen application (O2)

Code P1

Certificates (inspection, implementation, characteristics, material certificate)

Code Cx and Hx

Name plate and operating instruction language

Code Tx and Mx

Communication plug connector

Code Ux

Valve manifold installation

Code A1: Factory installation and pressure test of the ABB

M26 valve manifold.

Process connections

On standard process flange: 1/4-18 NPT on the process axis

Via adapter: 1/2-14 NPT on the process axis

Fastening screw threads: 7/16–20 UNF with 41.3 mm center distance

Process connection via diaphragm seal: see data sheet DS/S26

Electrical connections

Two 1/2-14 NPT or M20 x 1.5 threaded bores for cable glands, directly on housing.

Special communication connector (on request)

- HART: Straight or angled Harting Han 8D connector and one mating plug.
- FOUNDATION fieldbus, PROFIBUS PA: M12 x 1 or 7/8 in. plug

Terminals

HART version: Three connections for signal / external display, for wire cross sections of up to 2.5 mm² (14 AWG), and connection points for testing and communication purposes

Fieldbus versions: Two signal connections (bus connection) for wire cross sections of up to 2.5 mm² (14 AWG)

Grounding

Internal and external ground terminals are provided for 6 mm² (10 AWG) wire cross sections.

Mounting position

The transmitters can be installed in any position.

The electronic housing can be rotated into any position. A stop is provided to prevent overturning.

Weight

(without options or diaphragm seal)

Models 266MRT, 266RRT: Approx. 3.7 kg (8.2 lb)

Models 266GRT, 266ART: Approx. 2 kg (4.4 lb)

Add 1.5 kg (3.3 lb) for stainless steel housings.

Add 650 g (1.5 lb) for packaging.

Take into account additional weight of up to 50 kg (110 lb) for diaphragm seals.

Packaging

Carton

Configuration

Transmitter with HART communication and 4 ... 20 mA

Standard configuration

Transmitters are calibrated at the factory to the customer's specified measuring range. The calibrated range and measuring point number are provided on the name plate. If this data has not been specified, the transmitter will be delivered with the plate left blank and the following configuration:

Physical unit	kPa
4 mA	Zero
20 mA	Measuring range upper limit (URL)
Output	Linear
Damping	1 s
Transmitter interference mode	High alarm
Software tag (max. 8 characters)	Blank
Optional LCD display	PV in kPa; output in mA and in percent as bargraph

Any or all of the configurable parameters listed above - including the lower and upper range values (with the same unit of measurement) - can easily be changed using a portable HART handheld communicator or a PC running the configuration software with the DTM for 266 models. Specifications concerning the flange type and materials, O-ring and vent / drain valve materials, and additional device options are stored in the transmitter database.

Customer-specific configuration (option N6)

The following information can be specified in addition to the standard configuration parameters:

Description	16 alphanumeric characters
Supplementary information	32 alphanumeric characters
Date	Day, month, year

For the HART protocol, the following physical units are available for pressure measurements:

Pa, kPa, MPa
 inH₂O @ 4 °C, mmH₂O @ 4 °C, psi
 inH₂O @ 20 °C, ftH₂O @ 20 °C, mmH₂O @ 20 °C
 inHg, mmHg, Torr
 g/cm², kg/cm², atm
 mbar, bar

These and others are available for PROFIBUS and FOUNDATION fieldbus.

Transmitter with PROFIBUS PA communication

Standard configuration

Transmitters are calibrated at the factory to the customer's specified measuring range. The calibrated range and measuring point number are provided on the name plate. If this data has not been specified, the transmitter will be delivered with the plate left blank and the following configuration:

Measuring profile	Pressure
Physical unit	kPa
Output scale 0 %	Measuring range lower limit (LRL)
Output scale 100 %	Measuring range upper limit (URL)
Output	Linear
Upper alarm limit	Measuring range upper limit (URL)
Upper warning limit	Measuring range upper limit (URL)
Lower warning limit	Measuring range lower limit (LRL)
Lower alarm limit	Measuring range lower limit (LRL)
Hysteresis limit value	0.5 % of output scaling
PV filter time	0 s
Address (set using local control buttons)	126
Measuring point tag	30 alphanumeric characters
Optional LCD display	PV in kPa; output in percent as bargraph display

Any or all of the configurable parameters listed above - including the measuring range values (with the same unit of measurement) - can easily be changed using a PC running the configuration software with the DTM for 266 models. Specifications concerning the flange type and materials, O-ring and vent / drain valve materials, and additional device options are stored in the transmitter database.

Customer-specific configuration (option N6)

The following information can be specified in addition to the standard configuration parameters:

Description	32 alphanumeric characters
Supplementary information	32 alphanumeric characters
Date	Day, month, year

...Configuration

Transmitter with FOUNDATION fieldbus communication

Standard configuration

Transmitters are calibrated at the factory to the customer's specified measuring range. The calibrated range and measuring point number are provided on the name plate. If this data has not been specified, the transmitter will be delivered with the plate left blank and the analog input function block FB1 will be configured as follows:

Measuring profile	Pressure
Physical unit	kPa
Output scale 0 %	Measuring range lower limit (LRL)
Output scale 100 %	Measuring range upper limit (URL)
Output	Linear
Upper alarm limit	Measuring range upper limit (URL)
Upper warning limit	Measuring range upper limit (URL)
Lower warning limit	Measuring range lower limit (LRL)
Lower alarm limit	Measuring range lower limit (LRL)
Hysteresis limit value	0.5 % of output scaling
PV filter time	0 s
Measuring point tag	30 alphanumeric characters
Optional LCD display	PV in kPa; output in percent as bargraph display

The analog input function blocks FB2 and FB3 are each configured for the sensor temperature measured in °C and the static pressure measured in MPa. Any or all of the configurable parameters listed above - including the measuring range values - can easily be changed using a FOUNDATION fieldbus-compatible configuration tool. Specifications concerning the flange type and materials, O-ring and vent / drain valve materials, and additional device options are stored in the transmitter database.

Customer-specific configuration (option N6)

The following information can be specified in addition to the standard configuration parameters:

Description	32 alphanumeric characters
Supplementary information	32 alphanumeric characters
Date	Day, month, year

Mounting dimensions

(not design data) - dimensions in mm (inch)

Models 266MRT, 266RRT with barrel housing

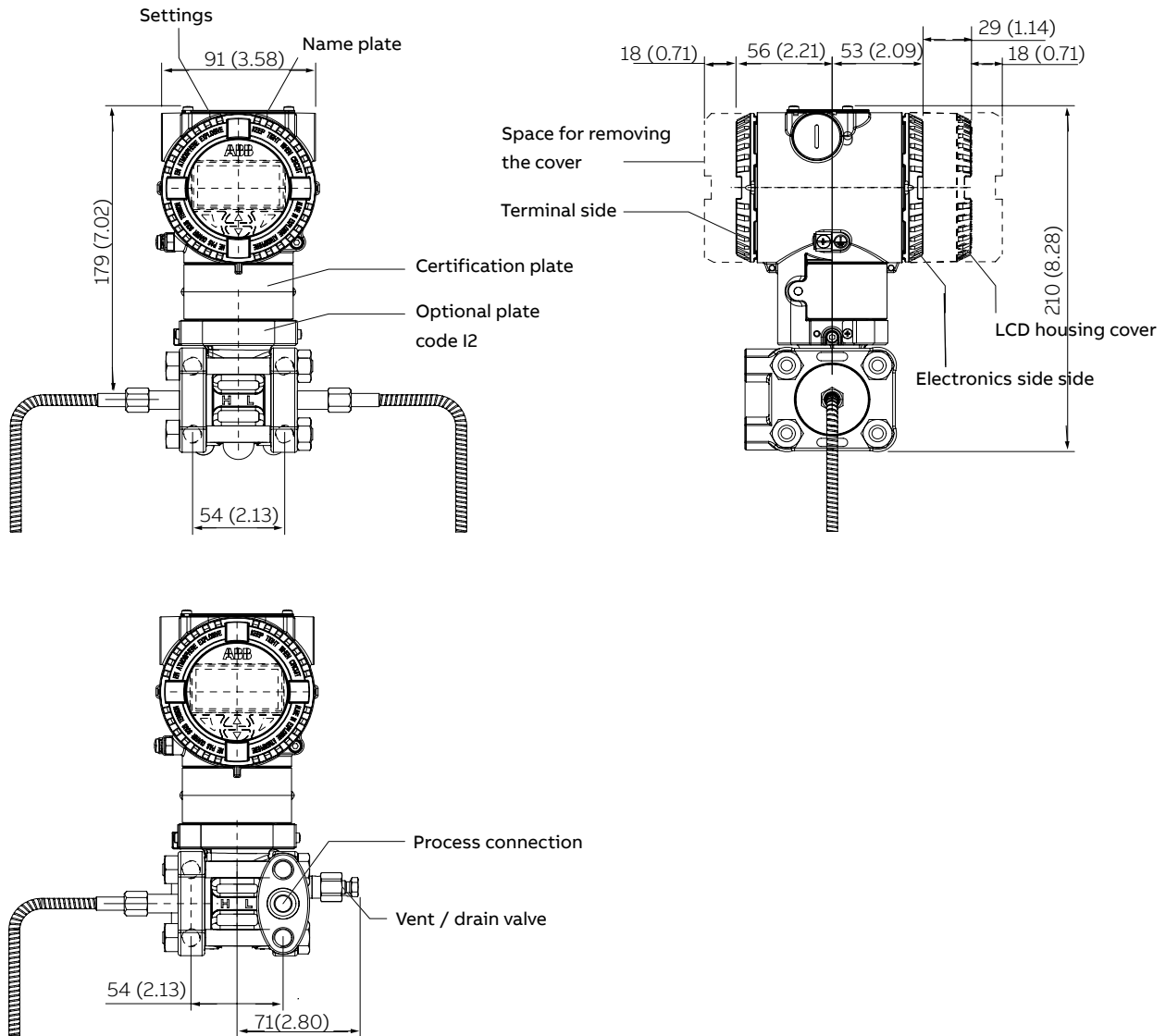

Fig. 2: Dimensions - Barrel housing

Important

In the case of model 266MRT with only one diaphragm seal, the threaded connection (1/4 – 18 NPT direct or 1/2 – 14 NPT via adapter) of the standard process flange, the gasket groove, and the gasket comply with IEC 61518. The screw-on thread for attaching the adapter or other devices (e.g., manifold) to the process flange is 7/16-20 UNF.

...Mounting dimensions

...(not design data) - dimensions in mm (inch)

Models 266MRT, 266RRT with barrel housing and mounting bracket, for vertical or horizontal mounting on 60 mm (2 in.) pipe

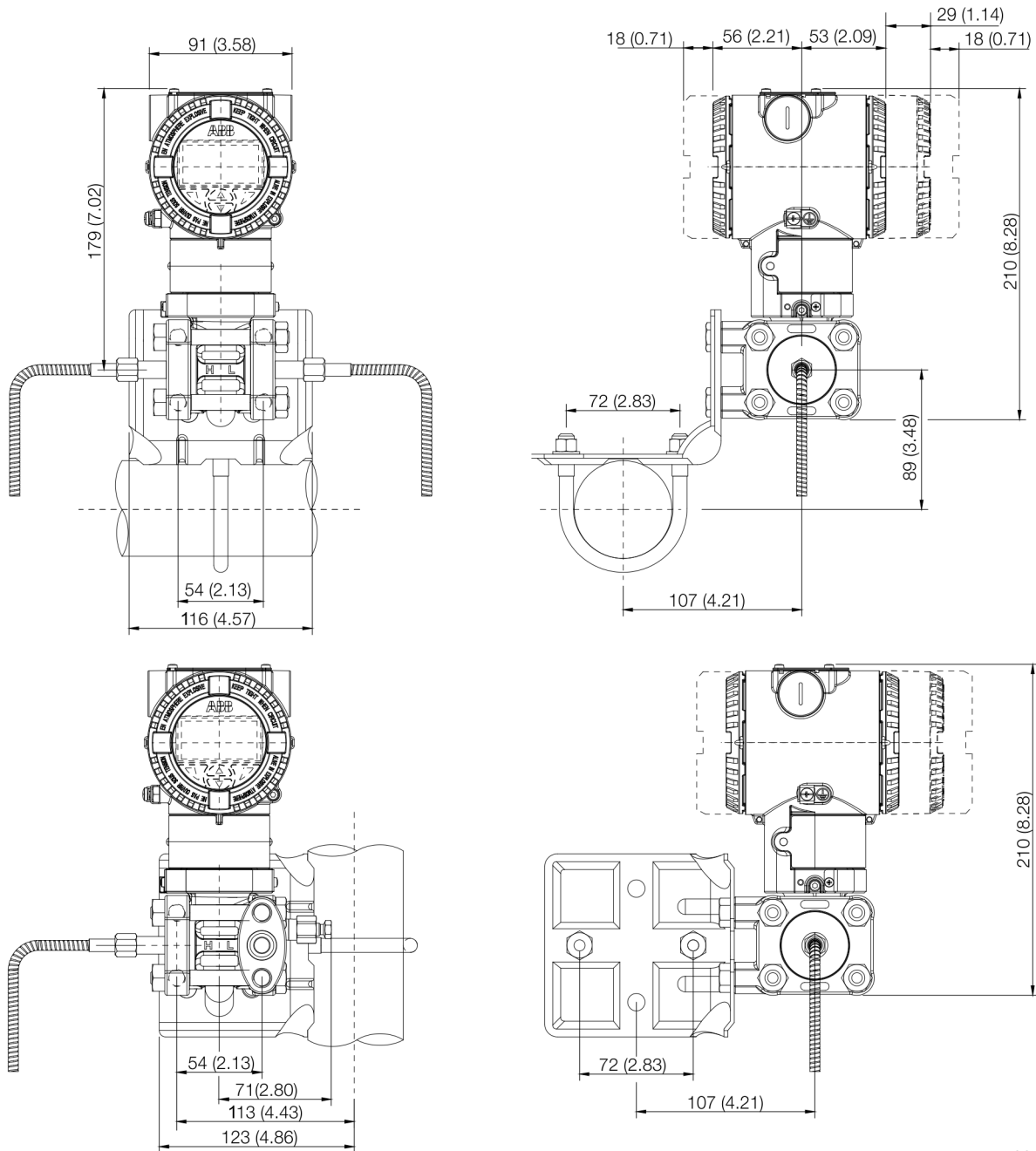

M10030

Fig. 3: Dimensions - Barrel housing with mounting bracket for vertical or horizontal mounting on 60 mm (2 in.) pipe

Models 266MRT, 266RRT with DIN housing and mounting bracket, for vertical or horizontal mounting on 60 mm (2 in.) pipe

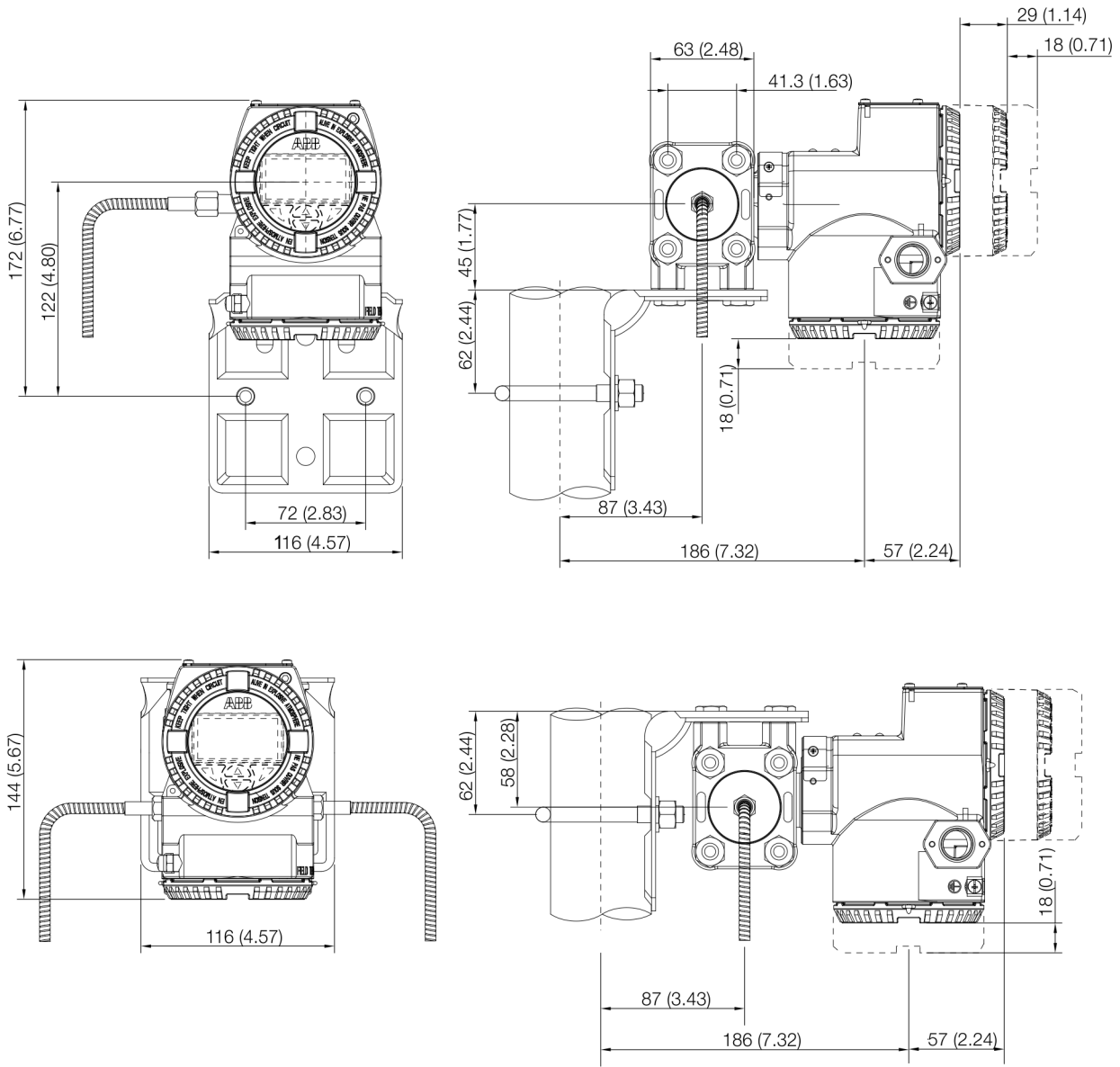

M10031

Fig. 4: Dimensions - DIN housing with mounting bracket for vertical or horizontal mounting on 60 mm (2 in.) pipe

...Mounting dimensions

...(not design data) - dimensions in mm (inch)

Models 266MRT with barrel housing and flush mounting bracket, for vertical or horizontal mounting on 60 mm (2 in.) pipe

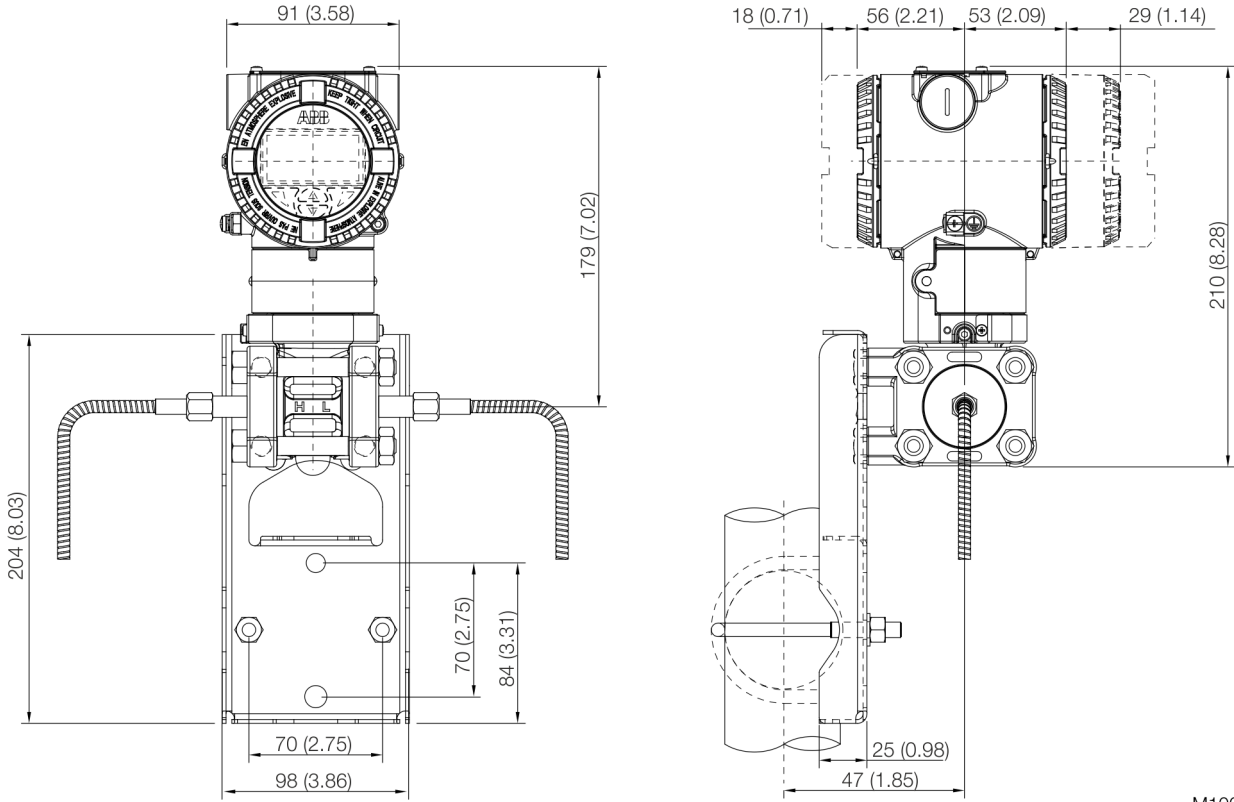

M10032

Fig. 5: Dimensions - Barrel housing with flush mounting bracket for vertical or horizontal mounting on 60 mm (2 in.) pipe

Models 266GRT, 266ART with barrel housing and mounting bracket, for vertical or horizontal mounting on 60 mm (2 in.) pipe

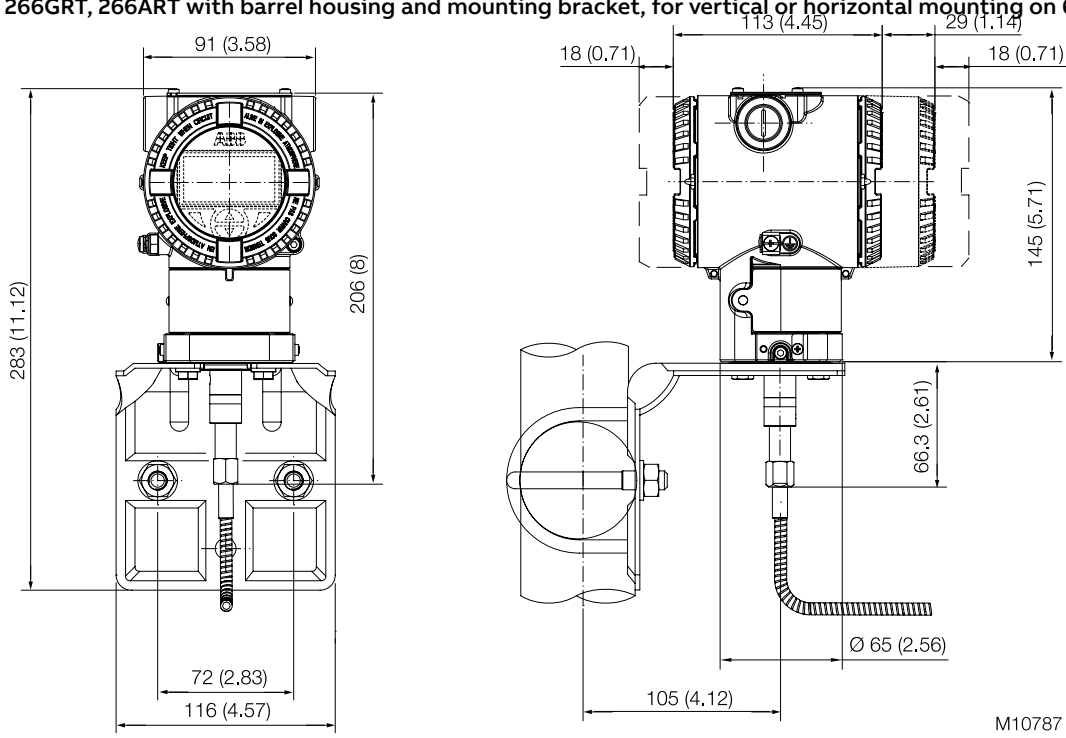

Fig. 6: Dimensions - Barrel housing with mounting bracket for vertical or horizontal mounting on 60 mm (2 in.) pipe

Models 266GRT, 266ART with DIN housing and mounting bracket, for vertical or horizontal mounting on 60 mm (2 in.) pipe

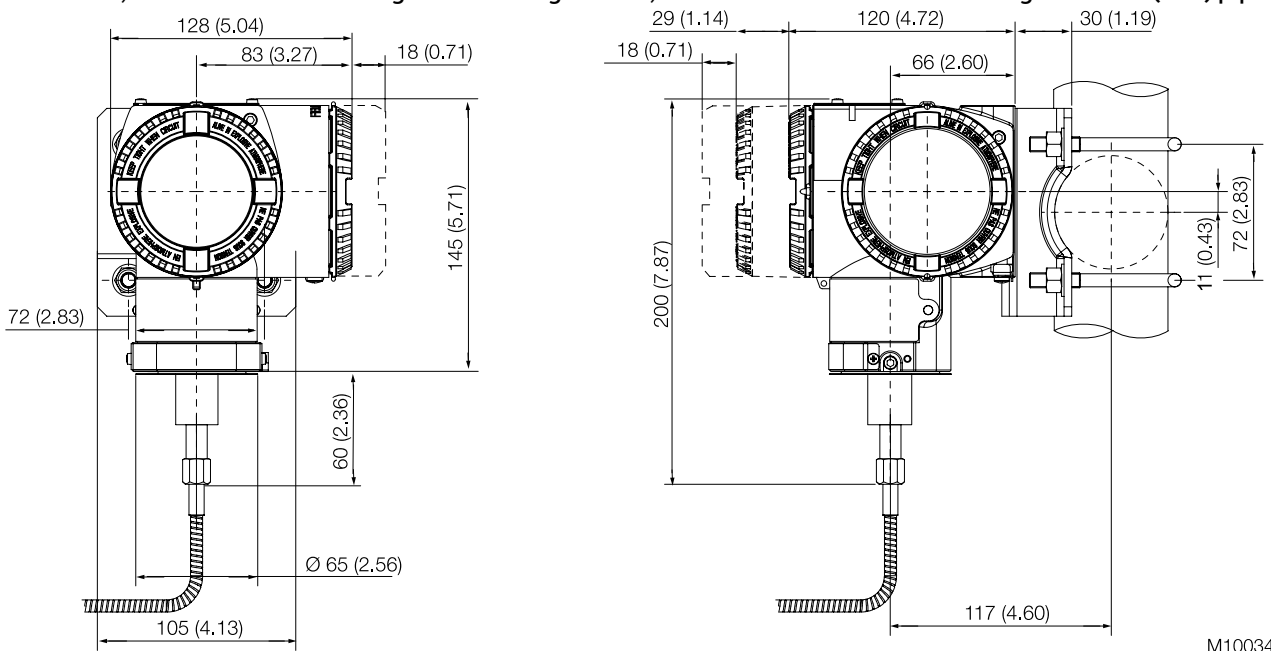

Fig. 7: Dimensions - DIN housing with mounting bracket for vertical or horizontal mounting on 60 mm (2 in.) pipe

Electrical connections

HART version

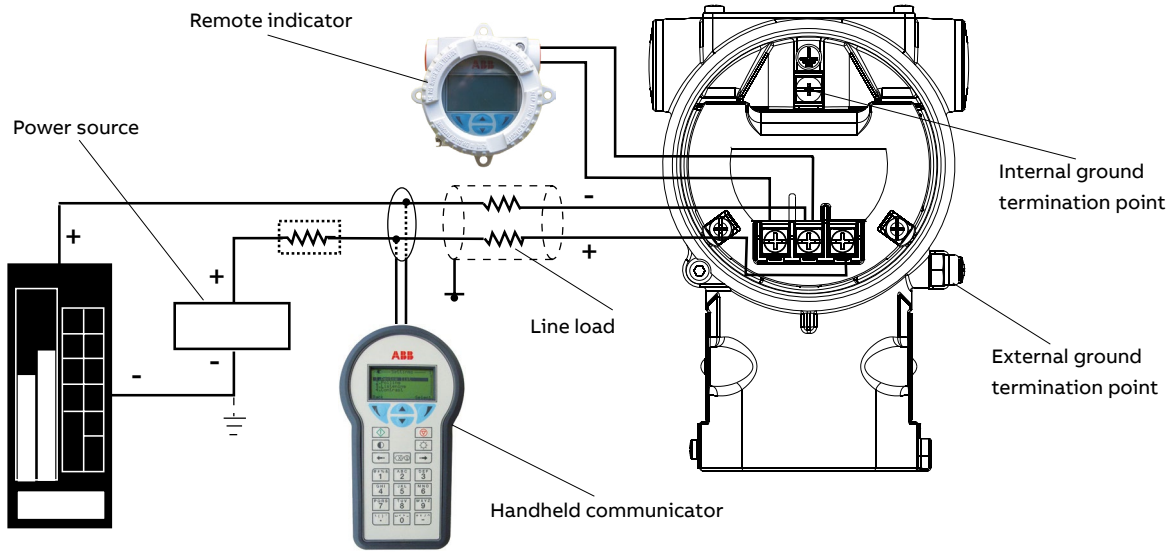

Fig. 8: Electrical connections - HART version

The HART handheld terminal can be connected to any wiring termination point in the loop, provided there is a minimum resistance of 250Ω between the handheld terminal and transmitter power supply. If this is less than 250Ω , additional resistance needs to be incorporated in order to enable communication.

Fieldbus versions

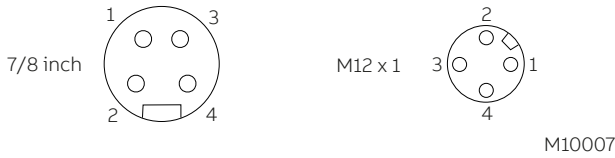

Fig. 9: Plug connector - fieldbus versions

Pin assignment (plug)		
Pin number	FOUNDATION fieldbus	PROFIBUS PA
1	DATA -	DATA +
2	DATA +	GROUND
3	SHIELD	DATA -
4	GROUND	SHIELD

Delivery scope: Plug connectors supplied loose without mating plug (female connector)

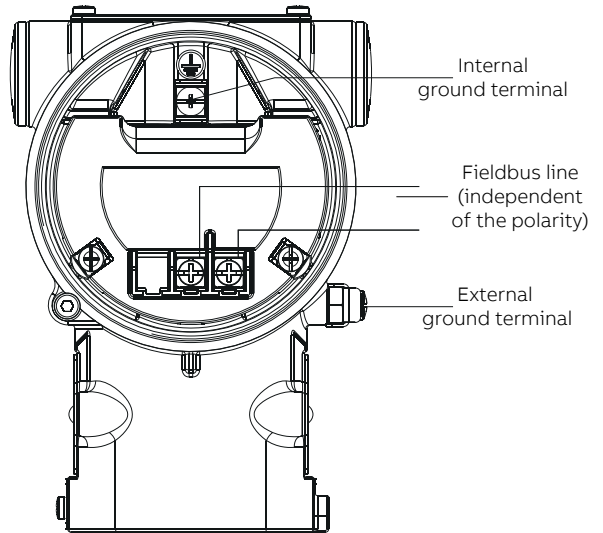

Fig. 10: Standard terminal strip

M10024-01

HART version

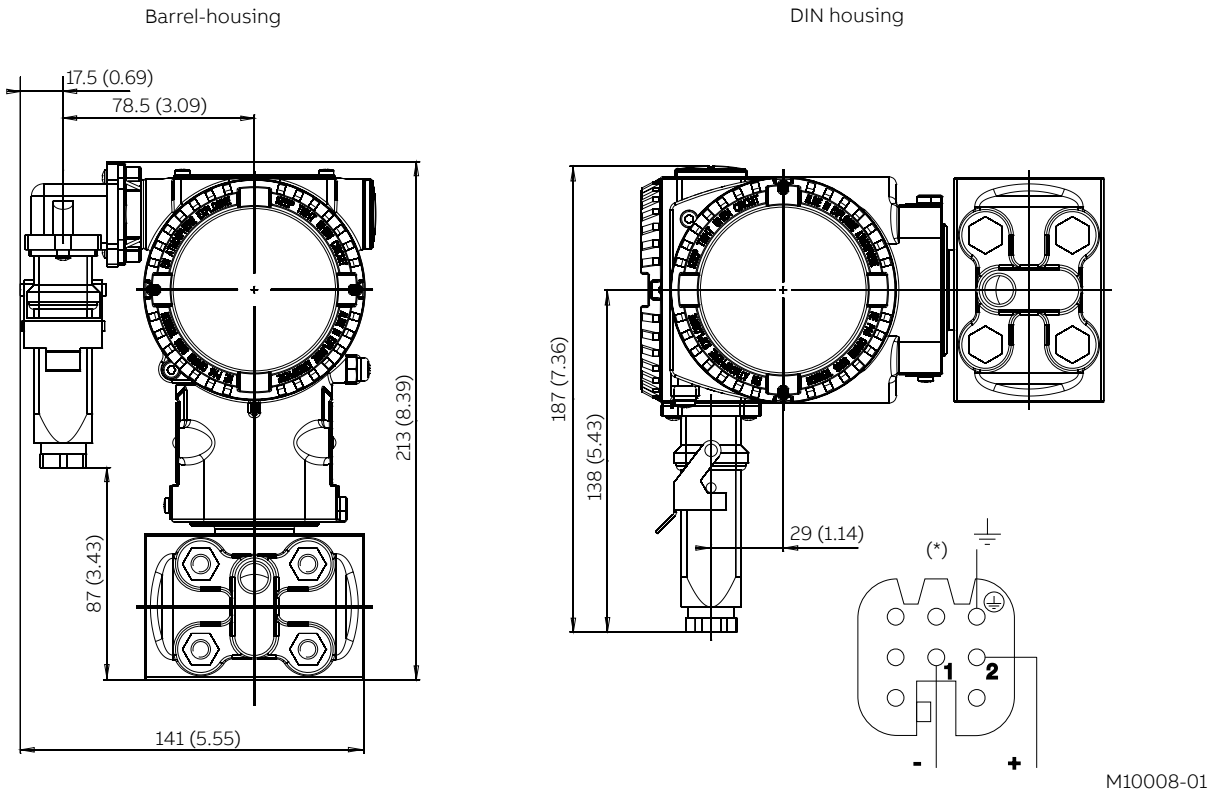

Fig. 11: Harting Han connection – differential pressure transmitter (application example)

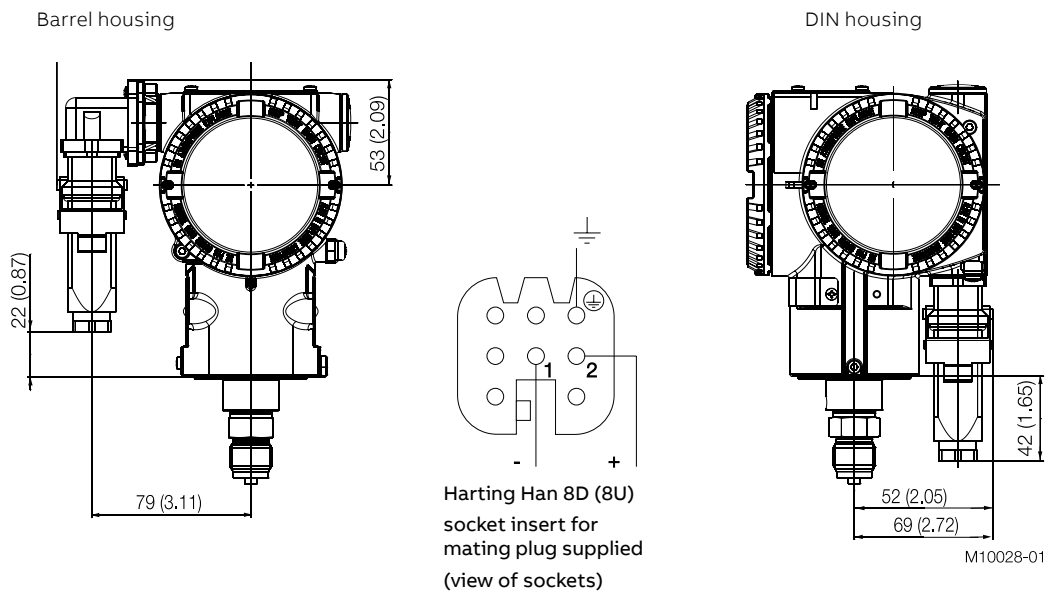

Fig. 12: Harting Han plug connector - gauge / absolute pressure transmitter (application example)

Ordering information

Basic ordering information model 266MRT Differential Pressure Transmitter with remote seal(s), maximum working pressure depending on seal / sensor limits

Select one character or set of characters from each category and specify complete catalog number.

Refer to additional ordering information and specify one or more codes for each transmitter if additional options are required.

Base model - 1st to 6th characters			2 6 6 M R T	X	X	X	X	X	X	X
Differential pressure transmitter with remote seal(s), base accuracy 0.04 %										
Sensor Span Limits – 7th character										
0.6 and 6 kPa	6 and 60 mbar	2.41 and 24 in. H ₂ O		C						
0.67 and 40 kPa	6.7 and 400 mbar	2.67 and 160 in. H ₂ O		F						
4.17 and 250 kPa	41.7 and 2500 mbar	16.7 and 1000 in. H ₂ O		L						
33.3 and 2000 kPa	0.333 and 20 bar	4.83 and 290 psi		N						
167 and 10000 kPa	1.67 and 100 bar	24.2 and 1450 psi		R						
Maximum Working Pressure – 8th character										
16 MPa	160 bar	2320 psi						C		
25 MPa	250 bar	3625 psi						Z		
41 MPa	410 bar	5945 psi						T		
Diaphragm Material / Fill Fluid – 9th character										
AISI 316L SST (1.4435)	Silicone oil			NACE				S		
Hastelloy® C-276	Silicone oil			NACE				K		
Monel 400®	Silicone oil			NACE				M		
AISI 316 L ss gold plated	Silicone oil			NACE				V		
Tantalum	Silicone oil			NACE				T		
AISI 316L SST (1.4435)	Inert fluid – Galden (Suitable for oxygen applications)			NACE				A		
Hastelloy® C-276	Inert fluid – Galden (Suitable for oxygen applications)			NACE				F		
Monel 400® gold-plated	Inert fluid – Galden (Suitable for oxygen applications)			NACE				C		
AISI 316 L ss gold plated	Inert fluid – Galden (Suitable for oxygen applications)			NACE				Y		
Tantalum	Inert fluid – Galden (Suitable for oxygen applications)			NACE				D		
Diaphragm seal	Silicone oil (Seal to be quoted separately)							R		
Diaphragm seal	Inert fluid – Galden (Seal to be quoted separately)							2		
Diaphragm Material / Fill Fluid – 9th character										
AISI 316L SST (1.4404 / 1.4408)	1/4-18 NPT female direct	(horizontal connection)		NACE				A		
AISI 316L SST (1.4404 / 1.4408)	1/2-14 NPT female through adapter	(horizontal connection)		NACE				B		
AISI 316L SST (1.4404 / 1.4408)	1/4-18 NPT female direct (DIN 19213)	(horizontal connection)		NACE				C		
Hastelloy® C-276	1/4-18 NPT female direct	(horizontal connection)		NACE				D		
Hastelloy® C-276	1/2-14 NPT female through adapter	(horizontal connection)		NACE				E		
Monel 400®	1/4-18 NPT female direct	(horizontal connection)		NACE				G		
Monel 400®	1/2-14 NPT female through adapter	(horizontal connection)		NACE				H		
AISI 316L SST (1.4404 / 1.4408)	For two seals construction			NACE				R		

continued on next page

	X	X	X
Bolts Material / Gaskets Material – 11th character			
AISI 316L SST (NACE - non exposed to H2S) / Viton (Suitable for oxygen applications)	3		
AISI 316L SST (NACE - non exposed to H2S) / PTFE (Max. 25 MPa / 250 bar / 3625 psi)	4		
AISI 316L SST (NACE - non exposed to H2S) / EPDM	5		
AISI 316L SST (NACE - non exposed to H2S) / Perbunan	6		
AISI 316L SST (NACE - non exposed to H2S) / Graphite	7		
AISI 316L SST (NACE - non exposed to H2S) / Without gaskets (For two seals construction)	R		
Housing Material / Electrical Connection – 12th character			
Aluminium alloy (Barrel type) 1/2-14 NPT			A
Aluminium alloy (Barrel type) M20 x 1.5			B
Aluminium alloy (Barrel type) Harting Han connector (General purpose only) (Note: 1)			E
Aluminium alloy (Barrel type) (General purpose only) (Note: 1)			G
AISI 316L SST (Barrel type)			S
AISI 316L SST (Barrel type)			T
Aluminium alloy (DIN type)			J
Aluminium alloy (DIN type) (General purpose only) (Note: 1)			K
Aluminium alloy (DIN type) (General purpose only) (Note: 1)			W
AISI 316L SST (Barrel type) (General purpose only) (Note: 1)			Z
Output – 13th character			
HART digital communication and 4 ... 20 mA			1
PROFIBUS PA			2
FOUNDATION fieldbus			3
HART digital communication and 4 ... 20 mA, SIL2 and SIL3-certified in acc. with IEC 61508			8

...Ordering information

ADDITIONAL ORDERING INFORMATION for model 266MRT

Add one or more 2-digit code(s) after the basic ordering information to select all required options

			XX	XX
Vent and drain valve Material / Position				
AISI 316L SST (1.4404)	On process axis	NACE	V1	
AISI 316L SST (1.4404)	On flanges side top	NACE	V2	
AISI 316L SST (1.4404)	On flanges side bottom	NACE	V3	
Hastelloy® C-276	On process axis	NACE	V4	
Hastelloy® C-276	On flanges side top	NACE	V5	
Hastelloy® C-276	On flanges side bottom	NACE	V6	
Monel 400®	On process axis	NACE	V7	
Monel 400®	On flanges side top	NACE	V8	
Monel 400®	On flanges side bottom	NACE	V9	
Explosion Protection Certification				
ATEX Intrinsic Safety Ex ia				E1
ATEX Explosion Proof Ex db				E2
ATEX Intrinsic Safety Ex ic				E3
FM approval (Canada) (Only available with 1/2-14 NPT or M20 electrical connections)				E4
FM approval (USA) (Only available with 1/2-14 NPT or M20 electrical connections)				E6
FM approvals (USA and Canada) Intrinsic Safety				EA
FM approvals (USA and Canada) Explosion Proof				EB
FM approvals (USA and Canada) Nonincendive				EC
Combined ATEX, IECEx and FM approvals (USA and Canada)				EN
Combined ATEX Ex ia, Ex db and Ex ic				EW
IECEX Intrinsic Safety Ex ia				E8
IECEX Explosion Proof Ex db				E9
IECEX Intrinsic Safety Ex ic				ER
Combined IEC Approval Ex ia and Ex db				EH
Combined IEC Approval Ex ia, Ex db and Ex ic				EI
NEPSI Intrinsic Safety Ex ia				EY
NEPSI Explosion Proof Ex d				EZ
NEPSI Intrinsic Safety Ex ic				ES
Combined NEPSI Ex ia and Ex d				EP
Combined NEPSI Ex ia, Ex d and Ex ic				EQ

	XX	XX	XX	XX	XX	XX
Other Explosion Protection Certifications						
TR CU EAC Ex ia Russia (incl. GOST Metrologic Approval)	W1					
TR CU EAC Ex d Russia (incl. GOST Metrologic Approval)	W2					
TR CU EAC Ex ia Kazakhstan (incl. GOST Metrologic Approval)	W3					
TR CU EAC Ex d Kazakhstan (incl. GOST Metrologic Approval)	W4					
TR CU EAC Ex ia Belarus (incl. GOST Metrologic Approval)	WF					
TR CU EAC Ex d Belarus (incl. GOST Metrologic Approval)	WG					
Integral LCD						
With integral LCD display		L1				
TTG (Through The Glass) integral digital LCD display		L5				
Mounting Bracket Shape / Material						
For pipe mounting / Carbon steel (Not suitable for AISI housing)				B1		
For pipe mounting / AISI 316 SST (1.4401) (Not suitable for AISI housing)				B2		
Flat type bracket / AISI 316 SST (1.4401) (Not suitable for AISI housing)				B5		
Surge /Transient Protector						
With integral surge / transient protector					S2	
Operating Instruction Language						
German						M1
Italian						M2
Spanish						M3
French						M4
English						M5
Swedish						M7
Polish						M9
Portuguese						MA
Turkish						MT
Label and Tag Language						
German						T1
Italian						T2
Spanish						T3
French						T4

...Ordering information

...ADDITIONAL ORDERING INFORMATION for model 266MRT

Add one or more 2-digit code(s) after the basic ordering information to select all required options

	XX	XX	XX	XX
Additional Tag Plate				
Supplemental wired-on stainless steel plate	I1			
Tag and certification stainless steel plates and laser printing of tag	I2			
Tag, certification and supplemental wired-on stainless steel plates and laser printing of tag	I3			
Configuration				
Standard – Pressure = inH2O/ psi at 68 °F; Temperature = deg. F		N2		
Standard – Pressure = inH2O/ psi at 39.2 °F; Temperature = deg. F		N3		
Standard – Pressure = inH2O/ psi at 20 °C; Temperature = deg. C		N4		
Standard – Pressure = inH2O/ psi at 4 °C; Temperature = deg. C		N5		
Custom		N6		
Configured for HART revision 5	(Note: 2)	NH		
Certificates				
Inspection certificate 3.1 acc. EN 10204 of calibration			C1	
Inspection certificate 3.1 acc. EN 10204 of helium leakage test of the sensor module			C4	
Declaration of compliance with the order 2.1 acc. EN 10204 for instrument design			C6	
Printed record of configured data of transmitter			CG	
PMI test on wetted parts			CT	
Approvals				
GOST Russia Metrologic Approval				Y1
GOST Kazakhstan Metrologic Approval				Y2
GOST Ukraine Metrologic Approval				Y3
GOST Belarus Metrologic Approval				Y4
Det Norske Veritas naval approval				YA
Conformity to NAMUR NE 021				YE

	XX	XX	XX
Material Traceability			
Inspection certificate 3.1 acc. EN 10204 of pressure-bearing and process wetted parts with analysis certificates as material			
(Note: 3)	H3		
Material certificate 2.2 acc. EN 10204 for the pressure bearing and process wetted parts	H4		
Connector			
Fieldbus 7/8 in. (Recommended for FOUNDATION fieldbus, supplied loose without female plug)			U1
Fieldbus M12 x 1 (Recommended for PROFIBUS PA, supplied loose without female plug)			U2
Harting Han 8D (8U), straight entry			U3
Harting Han 8D (8U), angle entry			U4
Harting Han 7D			U5
Harting Han 8D (8U) - For Four-Wire add-on Unit			U6
Harting Han 7D - For Four-Wire add-on Unit			U7
With cable gland M20 x 1.5			U8
Seal Type High / Low Pressure Side			
For ordering information please refer to seal data sheet DS/S26			

Note 1: Select connector with additional ordering code

Note 2: Not available with Output code 2, 3

Note 3: Minor parts with factory certificate acc. EN 10204

Standard delivery scope (changes possible with additional ordering code)

- Adapters supplied loose
- Plugs for process axis (no vent / drain valves)
- For standard applications (without explosion protection)
- No display, no mounting bracket, no surge protection
- Multilanguage short-form operating instruction and English labeling
- Configuration with kPa and °C units
- No test, inspection, or material certificates

...Ordering information

Basic ordering information for model 266RRT Absolute Pressure Transmitter with remote seal, overpressure depending on seal / sensor limits

Select one character or set of characters from each category and specify complete catalog number.

Refer to additional ordering information and specify one or more codes for each transmitter if additional options are required.

Base model - 1st to 6th characters				266RRT	X	X	X	X	X	X
Absolute pressure transmitter with remote seal, base accuracy 0.04 %										
Sensor Span Limits – 7th character										
2 and 40 kPa	20 and 400 mbar	8 and 160 in. H ₂ O	15 and 300 mm Hg	F						
12.5 and 250 kPa	125 and 2500 mbar	50 and 1000 in. H ₂ O	95 and 1875 mm Hg	L						
100 and 2000 kPa	1 and 20 bar	15 and 290 psi		N						
Maximum Working Pressure – 8th character										
16 MPa	160 bar	2320 psi		C						
25 MPa	250 bar	3625 psi		Z						
41 MPa	410 bar	5945 psi		T						
Diaphragm Material / Fill Fluid – 9th character										
Diaphragm seal	Silicone oil (Seal to be quoted separately)						R			
Diaphragm seal	Inert fluid – Galden (Seal to be quoted separately)						Z			
Process Connection Material / Type – 10th character										
Diaphragm seal (Except button type, seal to be quoted separately)							R			
Housing Material / Electrical Connection – 11th character										
Aluminium alloy (Barrel type)	1/2-14 NPT									A
Aluminium alloy (Barrel type)	M20 x 1.5									B
Aluminium alloy (Barrel type)	Harting Han connector	(General purpose only)	(Note: 1)							E
Aluminium alloy (Barrel type)	Fieldbus connector	(General purpose only)	(Note: 1)							G
AISI 316L SST (Barrel type)	1/2-14 NPT									S
AISI 316L SST (Barrel type)	M20 x 1.5									T
Aluminium alloy (DIN type)	M20 x 1.5									J
Aluminium alloy (DIN type)	Harting Han connector	(General purpose only)	(Note: 1)							K
Aluminium alloy (DIN type)	Fieldbus connector	(General purpose only)	(Note: 1)							W
AISI 316L SST (Barrel type)	Fieldbus connector	(General purpose only)	(Note: 1)							Z
Output – 12th character										
HART digital communication and 4 ... 20 mA (Options requested by "Additional ordering code")										1
PROFIBUS PA (Options requested by "Additional ordering code")										2
FOUNDATION fieldbus (Options requested by "Additional ordering code")										3
HART digital communication and 4 ... 20 mA, SIL2 and SIL3-certified to IEC 61508 (Options requested by "Additional ordering code")										8

...Ordering information

Additional ordering information for model 266RRT

Add one or more 2-digit code(s) after the basic ordering information to select all required options.

	XX	XX
Explosion Protection Certification		
ATEX Intrinsic Safety Ex ia	E1	
ATEX Explosion Proof Ex db	E2	
ATEX Intrinsic Safety Ex ic	E3	
FM approval (Canada) (Only available with 1/2-14 NPT or M20 electrical connections)	E4	
FM approval (USA) (Only available with 1/2-14 NPT or M20 electrical connections)	E6	
FM approvals (USA and Canada) Intrinsic Safety	EA	
FM approvals (USA and Canada) Explosion Proof	EB	
FM approvals (USA and Canada) Nonincendive	EC	
Combined ATEX, IECEx and FM approvals (USA and Canada)	EN	
Combined ATEX Ex ia, Ex db and Ex ic	EW	
IECEx Intrinsic Safety Ex ia	E8	
IECEx Explosion Proof Ex db	E9	
IECEx Intrinsic Safety Ex ic	ER	
Combined IEC Approval Ex ia and Ex db	EH	
Combined IEC Approval Ex ia, Ex db and Ex ic	EI	
NEPSI Intrinsic Safety Ex ia	EY	
NEPSI Explosion Proof Ex d	EZ	
NEPSI Intrinsic Safety Ex ic	ES	
Combined NEPSI Ex ia and Ex d	EP	
Combined NEPSI Ex ia, Ex d and Ex ic	EQ	
Other Explosion Protection Certifications		
TR CU EAC Ex ia Russia (incl. GOST Metrologic Approval)		W1
TR CU EAC Ex d Russia (incl. GOST Metrologic Approval)		W2
TR CU EAC Ex ia Kazakhstan (incl. GOST Metrologic Approval)		W3
TR CU EAC Ex d Kazakhstan (incl. GOST Metrologic Approval)		W4
TR CU EAC Ex ia Belarus (incl. GOST Metrologic Approval)		WF
TR CU EAC Ex d Belarus (incl. GOST Metrologic Approval)		WG

...Ordering information

...Additional ordering information for model 266RRT

Add one or more 2-digit code(s) after the basic ordering information to select all required options.

	XX	XX	XX	XX	XX	XX
Integral LCD						
With integral LCD display	L1					
TTG (Through The Glass) integral digital LCD display	L5					
Mounting Bracket Shape / Material						
For pipe mounting / Carbon steel (Not suitable for AISI housing)		B1				
For pipe mounting / AISI 316 SST (1.4401) (Not suitable for AISI housing)		B2				
Flat type bracket / AISI 316 SST (1.4401) (Not suitable for AISI housing)		B5				
Surge /Transient Protector						
With integral surge / transient protector			S2			
Operating Instruction Language						
German					M1	
Italian					M2	
Spanish					M3	
French					M4	
English					M5	
Swedish					M7	
Polish					M9	
Portuguese					MA	
Turkish					MT	
Label and Tag Language						
German						T1
Italian						T2
Spanish						T3
French						T4
Additional Tag Plate						
Supplemental wired-on stainless steel plate (4 lines, 32 characters each)						I1
Laser printing of tag on stainless steel plate						I2
Stainless steel tag, certification and wire-on plates						I3

	XX	XX	XX	XX
Configuration				
Standard – Pressure = inH2O/ psi at 68 °F; Temperature = deg. F	N2			
Standard – Pressure = inH2O/ psi at 39.2 °F; Temperature = deg. F	N3			
Standard – Pressure = inH2O/ psi at 20 °C; Temperature = deg. C	N4			
Standard – Pressure = inH2O/ psi at 4 °C; Temperature = deg. C	N5			
Custom	N6			
Configured for HART revision 5	NH			
				(Note: 2)
Certificates				
Inspection certificate 3.1 acc. EN 10204 of calibration	C1			
Inspection certificate 3.1 acc. EN 10204 of helium leakage test of the sensor module	C4			
Declaration of compliance with the order 2.1 acc. EN 10204 for instrument design	C6			
Printed record of configured data of transmitter	CG			
PMI test on wetted parts	CT			
Approvals				
GOST Russia Metrologic Approval			Y1	
GOST Kazakhstan Metrologic Approval			Y2	
GOST Ukraine Metrologic Approval			Y3	
GOST Belarus Metrologic Approval			Y4	
Det Norske Veritas naval approval			YA	
Conformity to NAMUR NE 021			YE	
Material Traceability				
Inspection certificate 3.1 acc. EN 10204 of pressure-bearing and process wetted parts with analysis certificates as material verification				H3
				(Note: 3)
Material certificate 2.2 acc. EN 10204 for the pressure bearing and process wetted parts				H4

...Ordering information

...Additional ordering information for model 266RRT

Add one or more 2-digit code(s) after the basic ordering information to select all required options.

	XX	XX
Connector		
Fieldbus 7/8 in. (Recommended for FOUNDATION fieldbus, supplied loose without female plug)	U1	
Fieldbus M12 x 1 (Recommended for PROFIBUS PA, supplied loose without female plug)	U2	
Harting Han 8D (8U), straight entry	U3	
Harting Han 8D (8U), angle entry	U4	
Harting Han 7D	U5	
Harting Han 8D (8U) - For Four-Wire add-on Unit	U6	
Harting Han 7D - For Four-Wire add-on Unit	U7	
With cable gland M20 x 1.5	U8	
Seal Type High Pressure Side		
For ordering information please refer to seal data sheet DS/S26		

Note 1: Select connector with additional ordering code

Note 2: Not available with Output code 2, 3

Note 3: Minor parts with factory certificate acc. EN 10204

Standard delivery scope (changes possible with additional ordering code)

- For standard applications (without explosion protection)
- No display, no mounting bracket, no surge protection
- Multilanguage short-form operating instruction and English labeling
- Configuration with kPa and °C units
- No test, inspection, or material certificates

...Ordering information

Additional ordering information for model 266GRT

Add one or more 2-digit code(s) after the basic ordering information to select all required options.

	XX	XX
Explosion Protection Certification		
ATEX Intrinsic Safety Ex ia	E1	
ATEX Explosion Proof Ex db	E2	
ATEX Intrinsic Safety Ex ic	E3	
FM approval (Canada) (Only available with 1/2-14 NPT or M20 electrical connections)	E4	
FM approval (USA) (Only available with 1/2-14 NPT or M20 electrical connections)	E6	
FM approvals (USA and Canada) Intrinsic Safety	EA	
FM approvals (USA and Canada) Explosion Proof	EB	
FM approvals (USA and Canada) Nonincendive	EC	
Combined ATEX, IECEx and FM approvals (USA and Canada)	EN	
Combined ATEX Ex ia, Ex db and Ex ic	EW	
IECEX Intrinsic Safety Ex ia	E8	
IECEX Explosion Proof Ex db	E9	
IECEX Intrinsic Safety Ex ic	ER	
Combined IEC Approval Ex ia and Ex db	EH	
Combined IEC Approval Ex ia, Ex db and Ex ic	EI	
NEPSI Intrinsic Safety Ex ia	EY	
NEPSI Explosion Proof Ex d	EZ	
NEPSI Intrinsic Safety Ex ic	ES	
Combined NEPSI Ex ia and Ex d	EP	
Combined NEPSI Ex ia, Ex d and Ex ic	EQ	
Other Explosion Protection Certifications		
TR CU EAC Ex ia Russia (incl. GOST Metrologic Approval)		W1
TR CU EAC Ex d Russia (incl. GOST Metrologic Approval)		W2
TR CU EAC Ex ia Kazakhstan (incl. GOST Metrologic Approval)		W3
TR CU EAC Ex d Kazakhstan (incl. GOST Metrologic Approval)		W4
TR CU EAC Ex ia Belarus (incl. GOST Metrologic Approval)		WF
TR CU EAC Ex d Belarus (incl. GOST Metrologic Approval)		WG

	XX	XX	XX	XX	XX	XX
Integral LCD						
With integral LCD display	L1					
TTG (Through The Glass) integral digital LCD display	L5					
Mounting Bracket Shape / Material						
For horizontal or vertical pipe and wall mounting / carbon steel		B6				
For horizontal or vertical pipe and wall mounting / AISI 316 (1.4401)		B7				
Overvoltage protection						
With overvoltage protection (transient protector)			S2			
Language of documentation						
German				M1		
Italian				M2		
Spanish				M3		
French				M4		
English				M5		
Swedish				M7		
Polish				M9		
Portuguese				MA		
Turkish				MT		
Label and Tag Language (material)						
German					T1	
Italian					T2	
Spanish					T3	
French					T4	
Additional Tag Plate						
Tag plate made from stainless steel (4 lines with 30 characters each)						I1
Measuring point tag laser-printed onto stainless steel plate						I2
Measuring point, certification and tag plate made from stainless steel						I3

...Ordering information

...Additional ordering information for model 266GRT

Add one or more 2-digit code(s) after the basic ordering information to select all required options.

	XX	XX	XX	XX
Configuration				
Standard – Pressure = inH2O/ psi at 68 °F; Temperature = deg. F	N2			
Standard – Pressure = inH2O/ psi at 39.2 °F; Temperature = deg. F	N3			
Standard – Pressure = inH2O/ psi at 20 °C; Temperature = deg. C	N4			
Standard – Pressure = inH2O/ psi at 4 °C; Temperature = deg. C	N5			
Custom	N6			
Configured for HART revision 5	NH			
				(Note: 2)
Certificates				
Inspection certificate 3.1 acc. EN 10204 of calibration	C1			
Inspection certificate 3.1 acc. EN 10204 of helium leakage test of the sensor module	C4			
Declaration of compliance with the order 2.1 acc. EN 10204 for instrument design	C6			
Printed record of configured data of transmitter	CG			
PMI test on wetted parts	CT			
Approvals				
GOST Russia Metrologic Approval			Y1	
GOST Kazakhstan Metrologic Approval			Y2	
GOST Ukraine Metrologic Approval			Y3	
GOST Belarus Metrologic Approval			Y4	
Det Norske Veritas naval approval			YA	
Conformity to NAMUR NE 021			YE	
Material Traceability				
Inspection certificate 3.1 acc. EN 10204 of pressure-bearing and process wetted parts with analysis certificates as material verification				H3
				(Note: 3)
Material certificate 2.2 acc. EN 10204 for the pressure bearing and process wetted parts				H4

	XX	XX
Plug connector		
Fieldbus 7/8 in. (Recommended for FOUNDATION fieldbus, supplied loose without female plug)	U1	
Fieldbus M12 x 1 (Recommended for PROFIBUS PA, supplied loose without female plug)	U2	
Harting Han 8D (8U), straight entry	U3	
Harting Han 8D (8U), angle entry	U4	
Harting Han 7D	U5	
Harting Han 8D (8U) - For Four-Wire add-on Unit	U6	
Harting Han 7D - For Four-Wire add-on Unit	U7	
With cable gland M20 x 1.5	U8	
Seal Type High / Low Pressure Side		
For ordering information please refer to seal data sheet DS/S26		

Note 1: Select connector with additional ordering code

Note 2: Not available with Output code 2, 3

Note 3: Minor parts with factory certificate acc. EN 10204

Standard delivery scope (changes possible with additional ordering code)

- For standard applications (without explosion protection)
- No display, no mounting bracket, no surge protection
- Multilanguage short-form operating instruction and English labeling
- Configuration with kPa and °C units
- No test, inspection, or material certificates

...Ordering information

Main ordering information for model 266ART absolute pressure transmitter with remote diaphragm seal, overpressure limit dependent upon diaphragm seal / pressure sensor limits

Select one or more characters from each category and enter the complete catalog number.

Enter one or more codes for additional order information if you are purchasing optional extras for each transmitter.

Base model - 1st to 6th characters				2 6 6 A R T	X	X	X	X	X
Gauge pressure transmitter with remote seal, base accuracy 0.04 %									
Sensor Span Limits – 7th character									
1.2 and 6 kPa	12 and 60 mbar	4.82 and 24 in. H2O	9 and 45 mm Hg / 1 MPa (10 bar, 145 psi)	C					
2 and 40 kPa	20 and 400 mbar	15 and 300 mm Hg	/ 1 MPa (10 bar, 145 psi)	F					
12.5 and 250 kPa	125 and 2500 mbar	93.8 and 1.875 mm Hg	/ 3 MPa (30 bar, 435 psi)	L					
50 and 1000 kPa	0.5 and 10 bar	7.25 and 145 psi	/ 6 MPa (60 bar, 870 psi)	D					
150 and 3000 kPa	1.5 and 30 bar	21.7 and 435 psi	/ 6 MPa (60 bar, 870 psi)	U					
500 and 10000 kPa	5 and 100 bar	72.5 and 1450 psi	/ 30 MPa (300 bar, 4350 psi)	R					
Diaphragm Material / Fill Fluid – 8th character									
Diaphragm seal mounted	Silicone oil (specify diaphragm seal separately)							R	
Diaphragm seal mounted	Fluorocarbon - Galden (specify diaphragm seal separately)							2	
Diaphragm seal mounted	White oil (specify diaphragm seal separately)							N	
Process Connection Material / Type – 9th character									
Diaphragm seal (except in the case of button diaphragm seals, specify diaphragm seal separately)									R
Button diaphragm seal (specify button diaphragm seal separately)									G
Direct mount diaphragm seal (one direct mount seal to be quoted)									M
Housing Material / Electrical Connection – 10th character									
Aluminium alloy (Barrel type)	1/2-14 NPT								A
Aluminium alloy (Barrel type)	M20 x 1.5								B
Aluminium alloy (Barrel type)	Harting Han plug connector	(for standard applications)	(Note: 1)						E
Aluminium alloy (Barrel type)	Fieldbus plug connector	(for standard applications)	(Note: 1)						G
Stainless steel (Barrel type)	1/2-14 NPT								S
Stainless steel (Barrel type)	M20 x 1.5								T
Aluminium alloy (DIN type)	M20 x 1.5								J
Aluminium alloy (DIN type)	Harting Han plug connector	(for standard applications)	(Note: 1)						K
Aluminium alloy (DIN type)	Fieldbus plug connector	(for standard applications)	(Note: 1)						W
Stainless steel (Barrel type)	Fieldbus plug connector	(for standard applications)	(Note: 1)						Z
Output – 11th character									
HART digital communication and 4 ... 20 mA (Options requested by "Additional ordering code")									1
PROFIBUS PA (Options requested by "Additional ordering code")									2
FOUNDATION fieldbus (Options requested by "Additional ordering code")									3
HART digital communication and 4 ... 20 mA, SIL2 and SIL3-certified to IEC 61508 (Options requested by "Additional ordering code")									8

...Ordering information

Additional ordering information for model 266ART

Add one or more 2-digit code(s) after the basic ordering information to select all required options.

	XX	XX
Explosion Protection Certification		
ATEX Intrinsic Safety Ex ia	E1	
ATEX Explosion Proof Ex db	E2	
ATEX Intrinsic Safety Ex ic	E3	
FM approval (Canada) (Only available with 1/2-14 NPT or M20 electrical connections)	E4	
FM approval (USA) (Only available with 1/2-14 NPT or M20 electrical connections)	E6	
FM approvals (USA and Canada) Intrinsic Safety	EA	
FM approvals (USA and Canada) Explosion Proof	EB	
FM approvals (USA and Canada) Nonincendive	EC	
Combined ATEX, IECEx and FM approvals (USA and Canada)	EN	
Combined ATEX Ex ia, Ex db and Ex ic	EW	
IECEx Intrinsic Safety Ex ia	E8	
IECEx Explosion Proof Ex db	E9	
IECEx Intrinsic Safety Ex ic	ER	
Combined IEC Approval Ex ia and Ex db	EH	
Combined IEC Approval Ex ia, Ex db and Ex ic	EI	
NEPSI Intrinsic Safety Ex ia	EY	
NEPSI Explosion Proof Ex d	EZ	
NEPSI Intrinsic Safety Ex ic	ES	
Combined NEPSI Ex ia and Ex d	EP	
Combined NEPSI Ex ia, Ex d and Ex ic	EQ	
Other Explosion Protection Certifications		
TR CU EAC Ex ia Russia (incl. GOST Metrologic Approval)		W1
TR CU EAC Ex d Russia (incl. GOST Metrologic Approval)		W2
TR CU EAC Ex ia Kazakhstan (incl. GOST Metrologic Approval)		W3
TR CU EAC Ex d Kazakhstan (incl. GOST Metrologic Approval)		W4
TR CU EAC Ex ia Belarus (incl. GOST Metrologic Approval)		WF
TR CU EAC Ex d Belarus (incl. GOST Metrologic Approval)		WG

...Ordering information

...Additional ordering information for model 266ART

Add one or more 2-digit code(s) after the basic ordering information to select all required options.

	XX	XX	XX	XX	XX	XX
Integral LCD						
With integral LCD display	L1					
TTG (Through The Glass) integral digital LCD display	L5					
Mounting Bracket Shape / Material						
For pipe mounting / Carbon steel (Not suitable for AISI housing)		B1				
For pipe mounting / AISI 316 SST (1.4401) (Not suitable for AISI housing)		B2				
Flat type bracket / AISI 316 SST (1.4401) (Not suitable for AISI housing)		B5				
Surge /Transient Protector						
With integral surge / transient protector			S2			
Operating Instruction Language						
German					M1	
Italian					M2	
Spanish					M3	
French					M4	
English					M5	
Swedish					M7	
Polish					M9	
Portuguese					MA	
Turkish					MT	
Label and Tag Language						
German						T1
Italian						T2
Spanish						T3
French						T4
Additional Tag Plate						
Supplemental wired-on stainless steel plate (4 lines, 32 characters each)						I1
Laser printing of tag on stainless steel plate						I2
Stainless steel tag, certification and wire-on plates						I3

	XX	XX	XX	XX
Configuration				
Standard – Pressure = inH2O/ psi at 68 °F; Temperature = deg. F	N2			
Standard – Pressure = inH2O/ psi at 39.2 °F; Temperature = deg. F	N3			
Standard – Pressure = inH2O/ psi at 20 °C; Temperature = deg. C	N4			
Standard – Pressure = inH2O/ psi at 4 °C; Temperature = deg. C	N5			
Custom	N6			
Configured for HART revision 5	NH			
				(Note: 2)
Certificates				
Inspection certificate 3.1 acc. EN 10204 of calibration	C1			
Inspection certificate 3.1 acc. EN 10204 of helium leakage test of the sensor module	C4			
Declaration of compliance with the order 2.1 acc. EN 10204 for instrument design	C6			
Printed record of configured data of transmitter	CG			
PMI test on wetted parts	CT			
Approvals				
GOST Russia Metrologic Approval			Y1	
GOST Kazakhstan Metrologic Approval			Y2	
GOST Ukraine Metrologic Approval			Y3	
GOST Belarus Metrologic Approval			Y4	
Det Norske Veritas naval approval			YA	
Conformity to NAMUR NE 021			YE	
Material Traceability				
Inspection certificate 3.1 acc. EN 10204 of pressure-bearing and process wetted parts with analysis certificates as material verification				
				(Note: 3)
Material certificate 2.2 acc. EN 10204 for the pressure bearing and process wetted parts				H3
				H4

...Ordering information

...Additional ordering information for model 266ART

Add one or more 2-digit code(s) after the basic ordering information to select all required options.

	XX	XX
Connector		
Fieldbus 7/8 in. (Recommended for FOUNDATION fieldbus, supplied loose without female plug)	U1	
Fieldbus M12 x 1 (Recommended for PROFIBUS PA, supplied loose without female plug)	U2	
Harting Han 8D (8U), straight entry	U3	
Harting Han 8D (8U), angle entry	U4	
Harting Han 7D	U5	
Harting Han 8D (8U) - For Four-Wire add-on Unit	U6	
Harting Han 7D - For Four-Wire add-on Unit	U7	
With cable gland M20 x 1.5	U8	
Seal Type High Pressure Side		
For ordering information please refer to seal data sheet DS/S26		

Note 1: Select connector with additional ordering code

Note 2: Not available with Output code 2, 3

Note 3: Minor parts with factory certificate acc. EN 10204

Standard delivery scope (changes possible with additional ordering code)

- For standard applications (without explosion protection)
- No display, no mounting bracket, no surge protection
- Multilanguage short-form operating instruction and English labeling
- Configuration with kPa and °C units
- No test, inspection, or material certificates

IMPORTANT REMARK FOR ALL MODELS

The selection of suitable wetted parts and filling fluid for compatibility with the process media is a customer's responsibility, if not otherwise notified before manufacturing.

NACE compliance information

- 1 The materials of constructions comply with metallurgical recommendations of NACE MR0175/ISO 15156 for sour oil field production environments. As specific environmental limits may apply to certain materials, please consult latest standard for further details. Materials AISI 316 / AISI 316L, Hastelloy C-276, Monel 400 also conform to NACE MR0103 for sour refining environments.
- 2 NACE MR0175 addresses bolting requirements in two classes:
 - **Exposed bolts:** bolts directly exposed to the sour environment or buried, encapsulated or anyway not exposed to atmosphere
 - **Non exposed bolts:** the bolting must not be directly exposed to sour environments, and must be directly exposed to the atmosphere at all times.

266MRT, 266RRT bolting identified by "NACE" are in compliance to the requirements of NACE MR0175 when considered "non exposed bolting".

Trademarks

™ Hastelloy C-276 is a Cabot Corporation trademark

™ Hastelloy C-2000 is a Haynes International trademark

™ Monel is an International Nickel Co. trademark

™ Viton is a DuPont de Nemours trademark

™ DC200 is a Dow Corning Corporation trademark

™ DC704 is a Dow Corning Corporation trademark

™ Galden is a Montefluos trademark

™ Halocarbon is a Halocarbon Products Co. trademark

™ Neobee M 20 is a Stepan Company trademark

™ Esso Marcol 122 is an Esso Italiana trademark

™ Syltherm is a Dow Chemical Company trademark

ABB Ltd.**Measurement & Analytics**

Howard Road St. Neots
Cambridgeshire PE19 8EU
UK

Tel: +44 (0)1480 475321

Fax: +44 (0)1480 217948

ABB Inc.**Measurement & Analytics**

125 E. County Line Road
Warminster PA 18974

USA

Tel: +1 215 674 6000

Fax: +1 215 674 7183

abb.com/measurement

ABB S.p.A.**Measurement & Analytics**

Via Luigi Vaccani 4
22016 Tremezzina Loc. Ossuccio (CO)
Italy

Tel: +39 0344 58111

ABB Automation Products GmbH**Measurement & Analytics**

Schillerstr. 72
32425 Minden
Germany

Tel: +49 551 905 534

Fax: +49 551 905 555

We reserve the right to make technical changes or modify the contents of this document without prior notice. With regard to purchase orders, the agreed particulars shall prevail. ABB does not accept any responsibility whatsoever for potential errors or possible lack of information in this document.

We reserve all rights in this document and in the subject matter and illustrations contained therein. Any reproduction, disclosure to third parties or utilization of its contents – in whole or in parts – is forbidden without prior written consent of ABB.