

ABB MEASUREMENT & ANALYTICS | DATA SHEET

266DRH, 266HRH and 266NRH

Pressure transmitters with seals



Measurement made easy

Engineered solutions for all applications

Base accuracy

- from 0.06 % of calibrated span

Reliable sensing system coupled with very latest digital technologies

- provides large turn down ratio up to 60:1

Comprehensive sensor choice

- optimize in-use total performance and stability

Flexible configuration facilities

- provided locally via local LCD keypad

New TTG (Through-The-Glass) keypad technology

- allows quick and easy local configuration without opening the cover, even in explosion proof environments

IEC 61508 certification

- version for SIL2 (1oo1) and SIL3 (1oo2) applications

PED compliance to Sound Engineering Practice (SEP)

All welded constructions

- grant economically feasible and technically sound solutions
- ensuring total reliability at line pressure down to full vacuum

Wide range of seal types, fill fluids, materials and options

Special designed seals for tailored solutions

WirelessHART version

- the battery powered solution compliant to IEC 62591

Best-in-class battery life

- up to 10 years @ 32 s update time
- in-field replaceable

Product in compliance with Directive 2011/65/UE (RoHS II)

In-built advanced diagnostics

General description

Models detailed in this data sheet apply for those transmitters which include one or two remote seal(s) connected via a capillary to the transmitter sensor. Depending on the selected ordering code the following models are available:

- a) model 266DRH which allows a differential measurement using either
- two remote seals of same type and size or
 - one direct mount seal on positive side and one remote seal on negative side, of same type and size or
 - one remote seal on positive and a standard threaded connection direct 1/4 in. – 18 NPT on flange or 1/2 in. – 14 NPT through adapter, for the wet or dry leg on negative side opposite to seal, or
 - one direct mount seal on positive side and a standard threaded connection direct 1/4 in. – 18 NPT on flange or 1/2 in. – 14 NPT through adapter, for the wet or dry leg on negative side.
- b) model 266HRH or 266NRH have the remote or direct mount seal on the positive side and the user can select the suitable code for having the reference at atmospheric or vacuum pressure respectively for gauge or absolute measure. Direct mount seal is integral to the transducer by a short capillary connection inside a protective rigid tube. This construction forms a standalone single assembly suitable to be mounted to the process by the seal(s) mounting facilities. All data apply for identical characteristics of the two sides when the transmitter is differential with two seals.

Remote Seals Overview

The S26 seals are used in combination with 2600T transmitters, allowing differential, gauge or absolute pressure measurements.

Connection of the seal(s) to the relevant transmitter can be achieved as follows :

- directly mounted with a short capillary connecting the „integral“ seal to the transmitter sensor;
- through a capillary system which link the transmitter sensor to a „remote“ seal of any version.
- Using seals the transmitter can be selected with
- two seals using same fill fluid, capillary and diaphragm size
- one seal having the other side configured with a process flange for wet/dry leg connection or a blind flange providing vacuum or atmospheric reference.

Model 266HR/NR transmitters have always one remote seal only, with a selectable reference to atmosphere or vacuum respectively for gauge or absolute pressure measurements. The S26 Series Seal System is a protective device used to isolate 2600T series transmitters from the process fluid. The seal system provides a flexible diaphragm seal between the process fluid and a liquid filled capillary tube connected to the body of the transmitter. The diaphragm isolates the process fluid while the filled capillary tube hydraulically transmits the process pressure to the transmitter sensor. The capillary of remote seal is corrosion-resistant with robust

construction in stainless steel with spiral armour protection, also PVC jacket; PVC protection is always recommended except for high temperature application, where stainless steel armour is suggested. The all welded construction assures reliable operation over the widest range of operating temperature and under vacuum conditions.

For certain applications, use of seal is necessary to prevent the process fluid from leaving its enclosure, due to reasons such as :

- the process fluid has solids in suspension or is highly viscous and can foul impulse lines.
- the process fluid can solidify in impulse lines or the transmitter.
- the process fluid is too hazardous to enter the control area where the transmitter is located.
- the process temperature exceeds the recommended limits for the transmitter.
- the application is interface level or density measurement.
- Remote seals offer the required constant and equal specific gravity of the pressure transfer fluid on the high and low sides of the transmitter.
- the transmitter must be located away from the process for easier maintenance.

The S26 series is available with process connections for ASME, EN or JIS pipe flanges, wedge flow elements, chemical tees, and threaded pipe fittings. Extended diaphragm remote seals, suitable for connection to 2in - 3in or 4in flanged tank nozzles or flanged tees, permit the seal diaphragm to be located flush with the inside of a tank or pipe. Sanitary type seals meet the stringent requirements of sanitary food, dairy, pharmaceutical and BioTech applications, offering FDA approved fillings and compliance with 3-A Sanitary Standards. Fill fluids with FDA are defined as food fills and are Generally Recognized As Safe (GRAS) by the US Food and Drug Administration (FDA).

Seal system selection criteria

Application of an S26 system in direct mount or remote seal configuration to 2600T transmitters affects performances of original devices. Effects are evident in:

- Accuracy
- Temperature effects
- Dynamic response

Accuracy is only marginally affected when seal diaphragm stiffness is relevant compared with sensor stiffness.

This is the only characteristic of the S26 system which has role on accuracy performance. High stiffness of diaphragm associated with low URL might produce increased errors of linearity, hysteresis, and long term stability; when diaphragm stiffness is accuracy related also temperature effects are significantly affected.

Some basic considerations on diaphragm stiffness help understanding effects introduced by S26 system associated with transmitters. This is physically defined by the ratio between the pressure variation applied to the diaphragm and the corresponding volume variation. The stiffness is not linear along the whole diaphragm volumetric displacement, but the S26 design is such to maintain the system linear within the service conditions of the transmitter such as:

- Operating pressure range
- Operating static pressure (for differential transmitters)
- Ambient and process temperature limits

Diaphragm stiffness is a function of material and thickness (elastic coefficient), diameter (type), convolution shape and geometry (design defined).

S26 system has effect on temperature performance of the complete transmitter. This effect is mostly on zero of the instrument and is produced by the expansion of the fill fluid into the closed volume formed by the transmitter flange cavity the capillary volume and the remote seal volume. This volume filled with a fluid with specific expansion coefficient; change in temperature of the measuring device produce a volume variation which is absorbed by the remote diaphragm, whose stiffness produces a change in the fluid pressure: this is the zero error. In real application the transmitter/seal system is not the same and stable temperature. Therefore the errors referred in this document for each type of diaphragm and different fluids should be taken as a reference for qualitative evaluation and not a true behaviour in normal application conditions. Should again be recognized that the stiffness of diaphragm and in this case, the thermal coefficient of fluid are the parameter to take into account.

Application of S26 seal to transmitters increases the original time response. The amount of the increase depends from the number of elements and condition of the instrument as follow:

- transmitter sensor range
- physical configuration (i.e. a remote seal on other side)
- type of measure/number of seal (one or two)
- fill fluid viscosity of the S26 system applied
- ambient temperature (affects the transmitter and the capillary) and process temperature on the seal diaphragm
- capillary length

The delay introduced by the seal may be considered as an added constant time to the one of the associated transmitter.

For obtaining the best application solution:

- choose sensor code with URL closest to application SPAN
- select largest diameter diaphragm seal related to URL.
- keep the capillary length as short as possible
- select the fill fluid that suits the most extreme process conditions expected (highest temperature and lowest pressure) and it is compatible with the process fluid.
- In vacuum application, choose always the all welded version and mount the transmitter primary 30 cm/12 inches or more below the bottom seal connection.
- In a two-seal system use the same diaphragm size, capillary length and fill fluid on each side of the transmitter

Temperature errors optimization (option code DE)

Additional enhanced optimization performed during the production process allows to reduce errors caused by temperature changes on seal. Values detailed in relevant tables can be considered divided by 4 for the following conditions

- difference of capillary errors (per metre) when the two sides have different lengths
- difference of seal errors (process) when the two sides are equipped with different S26 types
- difference of system errors (ambient) when the transmitter uses one direct mount seal and one remote seal.

Ordering Information

The transmitter and each seal system are each identified by a product code number. These code numbers are stamped on the transmitter nameplate and each character identifies specific product features. Refer to ordering information for a detailed explanation of the product code numbers.

Industrial application in chemical, sanitary, food and any other process industries may require seal configurations and/or

process connection different from those reported in this document. Each "special" should be evaluated by ABB to check the correctness and its level of functionality. Ask for the "S26 series seal form" to define precisely the measuring problem and application requirements.

ABB can also cooperate with you by developing a special remote seal for problems requiring individual solutions.

PLEASE CONTACT YOUR LOCAL ABB OFFICE OR REPRESENTATIVE FOR ADDITIONAL INFORMATION, SPECIFIC SEAL DATA AND APPLICABILITY.

Specification – functional

Range and span limits

Sensor Code	Upper Range Limit (URL)	Lower Range Limit (LRL)				Minimum span	
		266DRH differential	266DRH gauge	266HRH gauge	266NRH absolute	basic	266HRH or 266NRH with S26KN
B	4 kPa	-4 kPa				0.2 kPa	
	40 mbar	-40 mbar				2 mbar	
	16 inH2O	-16 inH2O				0.8 inH2O	
E	16 kPa	-16 kPa	-16 kPa			0.8 kPa	
	160 mbar	-160 mbar	-160 mbar			8 mbar	
	64 inH2O	-64 inH2O	-64 inH2O			3.2 inH2O	
F	40 kPa	-40 kPa	-40 kPa	-40 kPa		0.67 kPa	1.34 kPa
	400 mbar	-400 mbar	-400 mbar	-400 mbar	0 abs	6.7 mbar	13.4 mbar
	160 inH2O	-160 inH2O	-160 inH2O	-160 inH2O		2.67 inH2O	5.34 inH2O
H	160 kPa	-160 kPa	-100 kPa (§)	-100 kPa (§)		2.67 kPa	5.34 kPa
	1600 mbar	-1600 mbar	-1 bar (§)	-1 bar (§)	0 abs	26.7 mbar	53.4 mbar
	642 inH2O	-642 inH2O	-14.5 psi (§)	-14.5 psi (§)		10.7 inH2O	21.4 inH2O
M	600 kPa	-600 kPa	-100 kPa (§)	-100 kPa (§)		10kPa	20 kPa
	6 bar	-6 bar	-1 bar (§)	-1 bar (§)	0 abs	0.1 bar	0.2 bar
	87 psi	-87 psi	-14.5 psi (§)	-14.5 psi (§)		1.45 psi	2.9 psi
P	2400 kPa	-2400 kPa	-100 kPa (§)	-100 kPa (§)		40 kPa	80 kPa
	24 bar	-24 bar	-1 bar (§)	-1 bar (§)	0 abs	0.4 bar	0.8 bar
	348 psi	-348 psi	-14.5 psi (§)	-14.5 psi (§)		5.8 psi	11.6 psi
Q	8000 kPa	-8000 kPa	-100 kPa (§)	-100 kPa (§)		134 kPa	267 kPa
	80 bar	-80 bar	-1 bar (§)	-1 bar (§)	0 abs	1.34 bar	2.67 bar
	1160 psi	-1160 psi	-14.5 psi (§)	-14.5 psi (§)		19.4 psi	38.7 psi
S	16000 kPa	-16000 kPa	-100 kPa (§)	-100 kPa (§)		267 kPa	534 kPa
	160 bar	-160 bar	-1 bar (§)	-1 bar (§)	0 abs	2.67 bar	5.34 bar
	2320 psi	-2320 psi	-14.5 psi (§)	-14.5 psi (§)		38.7 psi	77.4 psi
W	70000 kPa			-100 kPa (§)		1400 kPa	
	700 bar			-1 bar (§)		14 bar	
	10150 psi			-14.5 psi (§)		203 psi	
Z	105000 kPa			-100 kPa (§)		10500 kPa	
	1050 bar			-1 bar (§)		105 bar	
	15225 psi			-14.5 psi (§)		1522 psi	

(§) with atmospheric pressure reference of 100 kPa, 1 bar, 14.5 psi.

Span limits

Maximum span = URL

IT IS RECOMMENDED TO SELECT THE TRANSMITTER SENSOR CODE PROVIDING THE TURNDOWN VALUE AS LOWEST AS POSSIBLE TO OPTIMIZE PERFORMANCE CHARACTERISTICS.

Zero suppression and elevation

Zero and span can be adjusted to any value within the range limits detailed in the table as long as:
– calibrated span ≥ minimum span

Damping (feature not available for WirelessHART version)

Selectable time constant : between 0 and 60 s
This is in addition to sensor response time.

Turn on time

Operation within specification in less than 10 s with minimum damping.
Insulation resistance
> 100 MΩ at 500 V DC (terminals to earth)

Insulation resistance

> 100 MΩ at 500 V DC (terminals to earth)–

Specification – operative limits

REFER ALSO TO S26X DATA PAGES FOR POSSIBLE FURTHER LIMITATIONS DUE TO SEAL VARIANTS

Pressure limits

Overpressure limits

Model 266DRH	Fill fluid	Overpressure limits
Sensor F to S	Silicone oil	0.07 kPa abs, 0.7 mbar abs, 0.5 mmHg and 21 MPa, 210 bar, 3045 psi (1)
Sensor F to Q 266DRH High Static	Silicone oil	0.07 kPa abs, 0.7 mbar abs, 0.5 mmHg and 42 MPa, 420 bar, 6090 psi
Sensor E	Silicone oil	0.07 kPa abs, 0.7 mbar abs, 0.5 mmHg and 16 MPa, 160 bar, 2320 psi
Sensor B (266DRH only)	Silicone oil	0.07 kPa abs, 0.7 mbar abs, 0.5 mmHg and 7 MPa, 70 bar, 1015 psi
Sensor F to S	Inert (Galden)	0.135 kPa abs, 1.35 mbar abs, 1 mmHg and 21 MPa, 210 bar, 3045 psi (1)
Sensor E	Inert (Galden)	0.135 kPa abs, 1.35 mbar abs, 1 mmHg and 16 MPa, 160 bar, 2320 psi
Sensor F to S	Inert (Halocarbon)	0.4 kPa abs, 4 mbar abs, 3 mmHg and 21 MPa, 210 bar, 3045 psi (1)
Sensor F to Q 266DRH High Static	Inert (Halocarbon)	0.4 kPa abs, 4 mbar abs, 3 mmHg and 42 MPa, 420 bar, 6090 psi
Sensor E	Inert (Halocarbon)	0.4 kPa abs, 4 mbar abs, 3 mmHg and 16 MPa, 160 bar, 2320 psi

(1) 16 MPa, 160 bar, 2320 psi for AISI 316 ss NACE “exposed bolting”

Models 266HRH and 266NRH	Fill fluid	Overpressure limits
Sensor P, Q, S	Silicone oil	0.07 kPa abs, 0.7 mbar abs, 0.5 mmHg and 21 MPa, 210 bar, 3045 psi
Sensor F, H, M	Silicone oil	0.07 kPa abs, 0.7 mbar abs, 0.5 mmHg and 14 MPa, 140 bar, 2030 psi
Sensor P, Q, S	Inert (Galden)	0.135 kPa abs, 1.35 mbar abs, 1 mmHg and 21 MPa, 210 bar, 3045 psi
Sensor F, H, M	Inert (Galden)	0.135 kPa abs, 1.35 mbar abs, 1 mmHg and 14 MPa, 140 bar, 2030 psi
Sensor P, Q, S	Inert (Halocarbon)	0.4 kPa abs, 4 mbar abs, 3 mmHg and 21 MPa, 210 bar, 3045 psi
Sensor F, H, M	Inert (Halocarbon)	0.4 kPa abs, 4 mbar abs, 3 mmHg and 14 MPa, 140 bar, 2030 psi
Sensor W (266HRH only)	Silicone oil	0.07 kPa abs, 0.7 mbar abs, 0.5 mmHg and 105 MPa, 1050 bar, 15225 psi
Sensor Z (266HRH only)	No filling	0.07 kPa abs, 0.7 mbar abs, 0.5 mmHg and 135 MPa, 1350 bar, 19570 psi

Static pressure limits

The differential pressure transmitters, models 266DRH work within specifications between the following limits:

Sensors	Static pressure limits
Sensor F to S with 2 seals	0.07 kPa abs, 0.7 mbar abs, 0.5 mmHg and 21 MPa, 210 bar, 3045 psi (1)
Sensor F to Q 266DRH high static with 2 seals	0.07 kPa abs, 0.7 mbar abs, 0.5 mmHg and 42 MPa, 420 bar, 6090 psi
Sensor F to S with 1 seal	1.3 kPa abs, 13 mbar abs, 0.2 psia and 21 MPa, 210 bar, 3045 psi (1)
Sensor E with 2 seals	0.07 kPa abs, 0.7 mbar abs, 0.5 mmHg and 16 MPa, 160 bar, 2320 psi
Sensor E with 1 seal	1.3 kPa abs, 13 mbar abs, 0.2 psia and 16 MPa, 160 bar, 2320 psi
Sensor B with 2 seals	0.07 kPa abs, 0.7 mbar abs, 0.5 mmHg and 7 MPa, 70 bar, 1015 psi
Sensor B with 1 seal	1.3 kPa abs, 13 mbar abs, 0.2 psia and 7 MPa, 70 bar, 1015 psi

(1) 16 MPa, 160 bar, 2320 psi for AISI 316 ss NACE “exposed bolting”

Proof pressure

The transmitter can be exposed without leaking to line pressure of up to

Model	Sensor	Proof pressure
266DRH	Sensor F to S	40.25 MPa, 402.5 bar, 5836 psi
	Sensor F to Q high static	77 MPa, 770 bar, 11165 psi
	Sensor E	31.5 MPa, 315 bar, 4567 psi
266HRH	Sensor B	14 MPa, 140 bar, 2030 psi
	Sensor F, H, M	28 MPa, 280 bar, 4060 psi
266NRH	Sensor P, Q, S	40.25 MPa, 402.5 bar, 5836 psi
266HRH	Sensor W	171.5 MPa, 1715 bar, 24868 psi
	Sensor Z	210.5 MPa, 2105 bar, 30522 psi

or two times the flange rating of seal, whichever is less. Meet ANSI/ISA-S 82.03 hydrostatic test requirements.

Overpressure and static upper limit can be derated by the flange rating of seal, as follows:

Seal model S26RE to EN 1092-1	Carbon steel flange @ 120 °C	AISI 316 ss flange @ 20 °C
PN 16	16 bar	16 bar
PN 40	40 bar	40 bar
PN 63	63 bar	63 bar
PN 100	100 bar	100 bar

Seal model S26RA and S26RR to ASME B16.5	Carbon Steel @ 100 °F (38 °C)	AISI 316 ss flange @ 100 °F (38 °C)
Class 150	285 psi	275 psi
Class 300	740 psi	720 psi
Class 600	1480 psi	1440 psi
Class 900	2220 psi	2160 psi
Class 1500	3705 psi	3600 psi
Class 2500	6170 psi	6000 psi

Seal model S26RJ to JIS B 2220	Carbon steel flange @ 120 °C	AISI 316 ss flange @ 120 °C
10K	14 bar	14 bar
20K	36 bar	36 bar
40K	68 bar	68 bar

Seal model S26RH to ISO1 0423 (API 6A)	AISI 316 ss flange	
	-29 ... 38 °C (-20 ... 100 °F)	@ 93 °C (200 °C)
API 10000	69.5 MPa, 10000 psi	60 MPa, 8687 psi
API 15000	103.5 MPa, 15000 psi	89.2 MPa, 12937 psi

Seal model S26FE to EN 1092-1	AISI 316 L ss flange @ 20 °C
PN 16	16 bar
PN 40	40 bar
PN 63	63 bar
PN 100	100 bar

Seal model S26FA to ASME B16.5	AISI 316 L ss flange @ 100 °F (38 °C)
Class 150	230 psi
Class 300	600 psi
Class 600	1200 psi

Seal model S26ME to EN 1092-1	AISI 316 ss or Hastelloy C flange
PN 16 / 40	40 bar @ 25 °C (77 °F)

Seal model S26MA to ASME B16.5	AISI 316 L ss flange @ 25 °C (77 °F)	Hastelloy C flange @ 25 °C (77 °F)
Class 150	230 psi	290 psi
Class 300	600 psi	750 psi

The pressure limit decreases with increasing temperature above to the specified values as defined for the material, respectively for ASME B16.5, EN 1092-1, JIS or ISO 10423 standards.

Seal model S26TT bolting	Temperature range	Pressure limit
AISI 316 ss or Carbon steel	0 ... 100 °C (32 ... 212 °F)	21 MPa, 210 bar, 3045 psi
	-60 ... 0 °C (-76 ... 32 °F)	16 MPa, 160 bar, 2320 psi
Alloy steel	100 ... 360 °C (212 ... 680 °F)	16 MPa, 160 bar, 2320 psi
	0 ... 37.8 °C (32 ... 100 °F)	21 MPa, 210 bar, 3045 psi
	-48.3 ... 0 °C (-55 ... 32 °F)	16 MPa, 160 bar, 2320 psi
	37.8 ... 360 °C (100 ... 680 °F)	13 MPa, 130 bar, 1885 psi

Seal model S26SS	Pressure limit
Triclamp 2 in.	3.8 MPa, 38 bar, 550 psi
Triclamp 3 in.	2.4 MPa, 24 bar, 350 psi
Triclamp 4 in.	1.7 MPa, 17 bar, 250 psi
Union nut F50	2.5 MPa, 25 bar, 360 psi
Union nut F80	2.5 MPa, 25 bar, 360 psi
Cherry Burrel 2 in.	1.9 MPa, 19 bar, 275 psi
Cherry Burrel 3 in.	1.9 MPa, 19 bar, 275 psi
Cherry Burrel 4 in.	1.9 MPa, 19 bar, 275 psi
Sanitary flush 4 in.	1.9 MPa, 19 bar, 275 psi
Sanitary extended 4 in.	1.9 MPa, 19 bar, 275 psi
Beverage bolted type 1 1/2 in.	4 MPa, 40 bar, 580 psi
V-band clamp option	1 MPa, 10 bar, 145 psi
4in schedule 5 V-band clamp option	0.7 MPa, 7 bar, 100 psi

Seal model S26WA to ASME B16.5
up to 41.37 MPa, 413.7 bar, 6000 psi but not greater than rating of mounting flange (NOT SUPPLIED)

Seal model S26WE to EN 1092-1	
Form B1	40 MPa, 400 bar, 5800 psi
Form D	16 MPa, 160 bar 2320 psi
Form E	10 MPa, 100 bar, 1450 psi

but not greater than rating of mounting flange (NOT SUPPLIED).

...Specification – operative limits

...Pressure limits

Seal model S26BN	Temp. limits of 20 and 120 °C (68 and 248 °F)
Types 89, 90 and 92	42 MPa, 420 bar, 6090 psi
Types 91	35 MPa, 350 bar, 5075 psi

Seal model S26VN bolting	Temperature range	Pressure limit
Alloy steel	0 ... 37.8 °C (32 ... 100 °F)	16 MPa, 160 bar, 2320 psi
	-48.3 ... 0 °C (-55 ... 32 °F)	10 MPa, 100 bar, 1450 psi
	37.8 ... 360 °C (100 ... 680 °F)	10 MPa, 100 bar, 1450 psi

Seal model S26UN	
Union Connection	10.3 MPa, 103 bar, 1500 psi
With Chemical Tee Flange	2 MPa, 20 bar, 300 psi

Seal model S26PN	
3 in. ASME 600 integral flange	8 MPa, 80 bar, 1160 psi
2 in. ASME 2500 threaded flange	32 MPa, 320 bar, 4640 psi

Seal model S26JN	
up to 16 MPa, 160 bar, 2320 psi but not greater than rating of mounting flange (NOT SUPPLIED)	

Seal model S26KN	
1 in seal - sealing with gaskets	3 MPa, 30 bar, 435 psi
1 1/2 in seals - sealing with gasket	5 MPa, 50 bar, 725 psi
1 in seal with ball valve connection	4 MPa, 40 bar, 580 psi
1 in NPT, 1 1/2 in NPT	34.5 MPa, 345 bar, 5000 psi
G 1 in A, G 1 1/2 in A	60 MPa, 600 bar, 8700 psi

Flushing ring gasket material	Process limits	Process limits	
		Pressure (max.)	Temperature
Garlock	250000 (°F x psi)	6.9 MPa, 69 bar, 1000 psi	-73 and 204 °C (-100 and 400 °F)
		2.5 MPa, 25 bar, 362 psi	-100 and 380 °C (-148 and 716 °F)
PTFE		6 MPa, 60 bar, 870 psi	-100 and 250 °C (-148 and 482 °F)

Vacuum service for seals

Full vacuum subject to fill fluid limits.
Refer to FILL FLUID CHARACTERISTICS table.
Minimum pressure with seal tantalum diaphragm is 1 kPa abs, 10 mbar abs, 0.15 psia.

Temperature limits °C (°F)

Ambient
is the operating temperature

Models 266DRH	Ambient temperature limits
Silicone oil for sensor F to S	-40 and 85 °C (-40 and 185 °F)
Silicone oil for sensor B and E	-25 and 85 °C (-13 and 185 °F)
Inert (Galden) for sensor F to S	-20 and 85 °C (-4 and 185 °F)
Inert (Galden) for sensor E	-10 and 85 °C (14 and 185 °F)
Inert (Halocarbon) for sensor F to S	-20 and 85 °C (-4 and 185 °F)
Inert (Halocarbon) for sensor E	-10 and 85 °C (14 and 185 °F)

Models 266HRH - 266NRH	Ambient temperature limits
Silicone oil for sensor F to W	-40 and 85 °C (-40 and 185 °F)
Inert (Galden) for sensor F to S	-20 and 85 °C (-4 and 185 °F)
Inert (Halocarbon) for sensor F to S	-20 and 85 °C (-4 and 185 °F)
Sensor Z without filling	-40 and 85 °C (-40 and 185 °F)

Models 266XRH	Ambient temperature limits
LCD integral display	-40 and 85 °C (-40 and 185 °F)

LCD display may not be clearly readable below -20 °C (-4 °F)
or above +70 °C (+158 °F)

IMPORTANT

For Hazardous Atmosphere applications see the temperature range specified on the certificate/approval relevant to the aimed type of protection

Process

Models 266DRH (side without seal)	Process temperature limits
Silicone oil for sensor F to S	-40 and 121 °C (-40 and 250 °F) ⁽¹⁾
Silicone oil for sensor B and E	-25 and 121 °C (-13 and 250 °F) ⁽¹⁾
Inert (Galden) for sensor F to S	-20 and 100 °C (-4 and 212 °F) ⁽²⁾
Inert (Galden) for sensor E	-10 and 100 °C (14 and 212 °F) ⁽²⁾
Inert (Halocarbon) for sensor F to S	-20 and 100 °C (-4 and 212 °F) ⁽²⁾
Inert (Halocarbon) for sensor E	-10 and 100 °C (14 and 212 °F) ⁽²⁾
Viton gasket	-20 and 121 °C (-4 and 250 °F)

(1) 100 °C (212 °F) for application below atmospheric pressure

(2) 65 °C (150 °F) for application below atmospheric pressure

Process - seal

Refer to the following FILL FLUID CHARACTERISTICS table detailing characteristics of fill fluids when used in transmitters with seal(s) and further limitation for specific models and/or variants.

Fill fluid (application)	Process temperature and pressure limits				Specifications @ 25 °C (77°F)		
	Tmax °C (°F) @ Pabs > of	Pmin mbar abs (mmHg)	Tmax °C (°F) @ Pmin	Tmin °C (°F)	Specific gravity (kg/dm3)	Kinematic viscosity (cst)	Thermal expansion (x 10 ⁻³ /°C)
Silicone oil PMX 200 10 cSt	250 (480) @ 385 mbar	0.7 (0.5)	130 (266)	-40 (-40)	0.934	10	1.08
Silicone oil Baysilone PD5 5 cSt	250 (480) @ 900 mbar	0.7 (0.5)	45 (113)	-85 (-121)	0.923	5	0.98
Inert oil Galden G5 (oxygen service)	160 (320) @ 1 bar	2.1 (1.52)	60 (140)	-20 (-4)	1.82	4.4	1.1
Inert oil Halocarbon 4.2 (oxygen service)	180 (356) @ 425 mbar	4 (3)	70 (158)	-20 (-4)	1.87	6.3	0.864
Silicone polymer Syltherm XLT (cryogenic service)	100 (212) @ 118 mbar	2.1 (1.52)	20 (68)	-100 (-148)	0.852	1.4	1
Silicone oil for high temperature (for REMOTE SEAL)	375 (707) @ 1 bar	0.7 (0.5)	220 (428)	-10 (14)	1.07	39	0.77
Silicone oil for high temperature (for DIRECT MOUNT SEAL)	250 (480) @ 3.5 mbar	0.7 (0.5)	220 (428)	-10 (14)	1.07	39	0.77
Vegetable oil Neobee M-20 (food - sanitary) FDA approved	200 (390) @ 1 bar	10 (7.2)	20 (68)	-18 (0)	0.92	9.8	1.2
Mineral oil Esso Marcol 152 (food - sanitary) FDA approved	250 (480) @ 630 mbar	0.7 (0.5)	110 (230)	-6 (21)	0.86	30	0.80
Glycerin Water 70% (food - sanitary) FDA approved	93 (200) @ 1 bar	1000 (760)	93 (200)	-7 (20)	1.08	2	0.36

Absolute viscosity (cP) = Kinematic Viscosity (cSt) x Specific gravity at specified temperature.

The absolute viscosity value is used for response time calculation.

Material	Process temperature limits
Tantalum diaphragm	260 °C (500 °F) max.
PFA anti-stick coating	204 °C (400 °F) max.
PFA anti-corrosion/anti-stick coating	250 °C (482 °F) max.
AISI gold plated diaphragm	320 °C (608 °F) max.
PTFE gasket	-100 and 260 °C (-148 and 500 °F)
Viton gasket	-20 and 260 °C (-4 and 500 °F)
graphite gasket (except S26CN)	-100 and 360 °C (-148 and 680 °F)
graphite gasket for S26CN	-100 and 340 °C (-148 and 644 °F)
Silicone rubber gasket	-50 and 204 °C (-58 and 400 °F)
Ethylene Propylene gasket	-40 and 149 °C (-40 and 300 °F)
Ethylene Propylene gasket EPDM 3-A 18-03 Class II	-40 and 121 °C (-40 and 250 °F)

Seals model (mnemonic)	Process temperature limits
S26JN In-line type (J1, J1.5, J2, J3)	-40 and 180 °C (-40 and 356 °F)
S26KN Pulp & Paper (M1, M1.5 all)	-40 and 150 °C (-40 and 302 °F)
S26KN Pulp & Paper (Y1)	-20 and 130 °C (-4 and 266 °F)
S26SS Beverage (K1.5)	-40 and 150 °C (-40 and 302 °F)
S26SS with Ethylene Propylene gasket EPDM 3-A 18-03 Class II	-40 and 121 °C (-40 and 250 °F)
S26SS with Ethylene Propylene gasket	-40 and 149 °C (-40 and 300 °F)
S26XX with PFA anti-stick coating	max. 204 °C (max 400 °F)

Storage

Models 266xRH	Storage temperature limits
Storage limits	-50 and 85 °C (-58 and 185 °F)
LCD integral display	-40 and 85 °C (-40 and 185 °F)

...Specification – operative limits

Environmental limits

Electromagnetic compatibility (EMC)

Comply with 2014/30/UE to standards EN 61326-1:2013.
For IEC 61508 SIL certified transmitter to EN 61326-3-1:2008.
For transmitter with option "YE" to NAMUR NE 021 (2004).
Surge immunity level (with surge protector): 4 kV (according to IEC 61000-4-5 EN 61000-4-5)

Pressure equipment directive (PED)

Comply with 2014/68/UE to standards ANSI/ISA 61010-1:2012
Category III Module H for PS \geq than 20 MPa, 200 bar
Sound Engineering Practice (SEP) for PS < 20 MPa, 200 bar

Humidity

Relative humidity: up to 100 %
Condensing, icing: admissible

Vibration resistance

Accelerations up to 2 g at frequency up to 1000 Hz (according to IEC 60068-2-6)

Shock resistance

Acceleration: 50 g
Duration: 11 ms
(according to IEC 60068-2-27)

Wet and dust-laden atmospheres

The transmitter is dust and sand tight and protected against immersion effects as defined by IEC 60529 (2001) to IP 67 (IP 68 on request) or by NEMA Type 4X.
IP65 with Harting Han connector.
Aluminium and AISI housings as barrel version also comply to IP 66 as defined by IEC 60529 (2001).
IP66W/IP67W/IP68W as standard for Inmetro certification.

Vibration resistance

Accelerations up to 2 g at frequency up to 1000 Hz (according to IEC 60068-2-6)

Shock resistance

Acceleration: 50 g
Duration: 11 ms
(according to IEC 60068-2-27)

Wet and dust-laden atmospheres

The transmitter is dust and sand tight and protected against immersion effects as defined by IEC 60529 (2001) to IP 67 (IP 68 on request) or by NEMA Type 4X.
IP65 with Harting Han connector.
Aluminium and AISI housings as barrel version also comply to IP 66 as defined by IEC 60529 (2001).
IP66W/IP67W/IP68W as standard for Inmetro certification.

Hazardous atmospheres

(FOR ALL VERSIONS EXCEPT WirelessHART)

With or without integral display

INTRINSIC SAFETY Ex ia:

ATEX Europe (code E1) approval
II 1 G Ex ia IIC T6...T4 Ga and II 1/2 G Ex ia IIC T6...T4 Ga/Gb and II 1 D Ex ia IIIC T85 °C Da and II 1/2 D Ex ia IIIC T85 °C Da; IP67.
IECEX (code E8) approval
Ex ia IIC T6...T4 Ga/Gb and Ex ia IIIC T85 °C Da; IP67.
NEPSI China (code EY)
Ex ia IIC T4/T5/T6 Ga, Ex ia IIC T4/T5/T6 Ga/Gb,
Ex iaD 20 T85/T100/T135, Ex iaD 20/21 T85/T100/T135.

EXPLOSION PROOF:

ATEX Europe (code E2) approval
II 1/2 G Ex db IIC T6 Ga/Gb Ta=-50 °C to +75 °C and II 1/2 D Ex tb IIIC T85 °C Db Ta = -50 °C to +75 °C; IP67.
IECEX (code E9) approval
Ex db IIC T6 Ga/Gb Ta=-50 °C to +75 °C and Ex tb IIIC T85 °C Db Ta = -50 °C to +75 °C; IP67.
NEPSI China (code EZ)
Ex d IIC T6 Gb, Ex tD A21 IP67 T85 °C.

INTRINSIC SAFETY Ex ic:

ATEX Europe (code E3) type examination
II 3 G Ex ic IIC T6...T4 Gc and II 3 D Ex tc IIIC T85 °C Dc; IP67.
IECEX (code ER) type examination
Ex ic IIC T6...T4 Gc and Ex tc IIIC T85 °C Dc; IP67.
NEPSI China (code ES) type examination
Ex ic IIC T4~T6 Gc, Ex nA IIC T4~T6 Gc, Ex tD A22 IP67 T85 °C.
FM Approvals US (code E6) and FM Approvals Canada (code E4):
– Explosionproof (US): Class I, Division 1, Groups A, B, C, D; T5
– Explosionproof (Canada): Class I, Division 1, Groups B, C, D; T5
– Dust-ignitionproof: Class II, Division 1, Groups E, F, G; Class III, Div. 1; T5
– Flameproof (US): Class I, Zone 1 AEx d IIC T4 Gb
– Flameproof (Canada): Class I, Zone 1 Ex d IIC T4 Gb
– Nonincendive: Class I, Division 2, Groups A, B, C, D T6...T4
– Energy limited (US): Class I, Zone 2 AEx nC IIC T6...T4
– Energy limited (Canada): Class I, Zone 2 Ex nC IIC T6...T4
– Intrinsically safe: Class I, II, III, Division 1, Groups A, B, C, D, E, F, G T6...T4
Class I, Zone 0 AEx ia IIC T6...T4 (US)
Class I, Zone 0 Ex ia IIC T6...T4 (Canada)

Type 4X, IP67 for all above markings.

COMBINED FM Approvals US and Canada

– Intrinsically safe (code EA)

COMBINED ATEX, FM and IECEX Approvals (code EN)

Technical Regulations Customs Union EAC (Russia, Kazakhstan, Belarus), Inmetro (Brazil), Kosha (Korea)

(ONLY FOR WirelessHART VERSION)

With or without integral display

INTRINSIC SAFETY:

ATEX Europe (code E1) approval
II 1 G Ex ia IIC T4 and II 1/2 G Ex ia IIC T4.
IECEX (code E8) approval
Ex ia IIC T4.

FM Approvals US and FM Approvals Canada:

– Intrinsically safe: Class I, Div. 1, Groups A, B, C, D; T4 (code EA)
Class I, Zone 0 AEx ia IIC T4, Gb (FM US)
Class I, Zone 0 Ex ia IIC T4, Gb (FM Canada)

IMPORTANT

REFER TO CERTIFICATES FOR AMBIENT TEMPERATURE RANGES RELATED TO THE DIFFERENT TEMPERATURE CLASSES.

HIGH STATIC VERSION IS NOT IN COMPLIANCE WITH ISA 12.27.01 FOR SEALING REQUIREMENTS, SPECIFICALLY FOR FM APPROVAL (Canada).

Specification - Electrical Characteristics and Options

Optional indicators

Integrated digital display

(code LS; only with HART standard functionality)

Wide screen LCD, 128 x 64 pixel,
52.5 x 27.2 mm (2.06 x 1.07 in.) dot matrix.
Two keys for zero/span or without keypad.
User selectable application-specific visualizations.
Display may also indicate static pressure, sensor temperature and diagnostic messages.



Integral display with integral keypad

(code L1; not with HART standard functionality)

Wide screen LCD, 128 x 64 pixel,
52.5 x 27.2 mm (2.06 x 1.07 in.) dot matrix.
Multilanguage. Four keys for configuration and management of device.
Easy setup for quick commissioning.
User selectable application-specific visualizations.
Totalized and instantaneous flow indication.
Display may also indicate static pressure, sensor temperature and diagnostic messages and provides configuration facilities.



Integral display with Through-The-Glass (TTG) activated keypad (code L5; not with HART standard functionality)

As above integral display but equipped with the innovative TTG keypad allowing the activation of the configuration and management menus of the device without the need of removing the transmitter housing cover. TTG keypad is protected against accidental activations.



Optional surge protection

Up to 4kV

- voltage 1.2 μs rise time / 50 μs delay time to half value
- current 8 μs rise time / 20 μs delay time to half value

Process diagnostics (PILD)

Plugged impulse line detection (PILD) generates a warning via communication (HART, PA, FF). The device can be configured to drive the output to "Alarm current" or set a status "BAD".

HART® digital communication and 4 to 20 mA output – Standard and Advanced functionality

Device type: 1a06_{hex} (listed with HCF)

Power supply

The transmitter operates from 10.5 to 42 V DC with no load and is protected against reverse polarity connection (additional load allows operations over 42 V DC). For Ex ia and other intrinsically safe approval power supply must not exceed 30 V DC. Minimum operating voltage increases to 12.3 V DC with optional surge protector or to 10.8 V DC with optional conformity to NAMUR NE 21 (2004).

Ripple

20 mV max on a 250 Ω load as per HART specifications.

Load limitations

4 to 20 mA and HART total loop resistance :

$$R \text{ (k}\Omega\text{)} = \frac{\text{Supply voltage} - \text{min. operating voltage (V DC)}}{22 \text{ mA}}$$

A minimum of 250 Ω is required for HART communication.

Output signal

Two-wire 4 to 20 mA, user-selectable for linear or square root output, power of $^{3/2}$ or $^{5/2}$, square root for bidirectional flow, 22 points linearization table (i.e. for horizontal or spherical tank level measurement). HART® communication provides digital process variable superimposed on 4 to 20 mA signal, with protocol based on Bell 202 FSK standard.
HART revision 7 is the default HART output.
HART revision 5 is selectable on request.

Output current limits (to NAMUR NE 43 standard)

Overload condition

- Lower limit: 3.8 mA (configurable from 3.8 to 4 mA)
- Upper limit: 20.5 mA (configurable from 20 to 21 mA)

Alarm current

- Lower limit: 3.6 mA (configurable from 3.6 to 4 mA)
- Upper limit: 21 mA (configurable from 20 to 23 mA, limited to 22 mA for HART Safety; apply for electronics release 7.1.15 or later)

Factory setting: high alarm current.

...Specification – electrical characteristics and options

IEC 62591 WirelessHART® output

Device type: 1a06hex (listed with HCF)
 Network ID: ABBhex (2747 decimal)
 Join keys: 57495245_{hex} (1464422981) 4c455353_{hex} (1279611731)
 4649454_{hex} (1179206988) 444b4559_{hex} (1145783641).

Power Supply

1x D-cell size lithium-thionyl chloride battery.
 Battery life: 10 years at 32 sec. update time, 8 years at 16 sec. update time or 5 years at 8 sec. update time.
 (at reference conditions of 25 ± 2 °C ambient temperature, data routed from 3 additional devices, LCD off).

THE BATTERY CAN BE REPLACED IN FIELD, ALSO IN HAZARDOUS CLASSIFIED AREA.

Output signal

IEC 62591 WirelessHART Version 7.5 (IEEE 802.15.4-2006);
 Frequency band: 2.4 GHz DSSS
 Update rate: user selectable from 1 sec. to 60 min.

Integrated adjustable omnidirectional antenna

– Output radio frequency: maximum 10 mW (10 dBm) EIRP
 – Range: up to 300 m. (328 yds.)
 Minimum distance between antenna and person is 0.2 m. (8 in.)

Telecommunications directive

Every wireless measuring device must be certified in accordance with the telecommunications directive, in this case the frequency range. This certification is country-specific.

European directives

Radio Equipment & Telecommunications Terminal Equipment Directive 2014/53/UE to standards EN 60950-1:2013, EN 62311:2008, EN 301 489-1 V1.9.2, EN 301 489-17 V2.2.1, EN 300 328 v1.8.1.
 In Europe, use of the 2400 - 2483.5 MHz frequency band is not harmonized. Country-specific regulations must be observed.

Restrictions for Norway

Operation not permitted within a radius of 20 km around Ny-Alesund in Svalbard. For more information, see www.npt.no Norway Posts and Telecommunications site

Extra-european radio frequency licences

USA to FCC Part 15.247:2009;
 Canada to IC RSS-210 and ICES-003;
 Argentina; United Arab Emirates (UAE); India; Mexico.

PROFIBUS® PA output

Device type

Pressure transmitter compliant to Profiles 3.0.1
 Identification number: 3450 (hex)

Power supply

The transmitter operates from 9 to 32 V DC , polarity independent, with or without surge protector.
 For Ex ia approval power supply must not exceed 17.5 V DC.
 Intrinsic safety installation according to FISCO model.

Current consumption

operating (quiescent): 15 mA
 fault current limiting: 20 mA max.

Output signal

Physical layer in compliance to IEC 1158-2/EN 61158-2 with transmission to Manchester II modulation, at 31.25 kbit/s.

Output interface

PROFIBUS PA communication according to Profibus DP50170 Part 2/DIN 19245 part 1–3.

Output update time

25 ms

Data blocks

3 analog input, 1 physical.

Additional blocks

1 Pressure with calibration transducer block
 1 Advanced Diagnostics transducer block including Plugged Input Line Detection
 1 Local Display transducer block

Transmitter failure mode

On gross transmitter failure condition, detected by self-diagnostics, the output signal can be driven to defined conditions, selectable by the user as safe, last valid or calculated value.
 If electronic failure or short circuit occur the transmitter consumption is electronically limited at a defined value (20 mA approx), for safety of the network.

FOUNDATION Fieldbus™ output

Device type

LINK MASTER DEVICE
 Link Active Scheduler (LAS) capability implemented.
 Manufacturer code: 000320_{hex}
 Device type code: 0007_{hex}

Power supply

The transmitter operates from 9 to 32 V DC, polarity independent, with or without surge protector.
 For Ex ia approval power supply must not exceed 24 V DC (FF-816 certification) or 17.5 V DC (FISCO certification).

Current consumption

operating (quiescent): 15 mA
 fault current limiting: 20 mA max.

Output signal

Physical layer in compliance to IEC 61158-2/EN 61158-2.
 Transmission to Manchester II modulation, at 31.25 kbit/s.

Function blocks/execution period

3 enhanced Analog Input blocks/25 ms max (each)
 1 enhanced PID block/40 ms max.
 1 standard ARithmetic block/25 ms
 1 standard Input Selector block/25 ms
 1 standard Control Selector block/25 ms
 1 standard Signal Characterization block/25 ms
 1 standard Integrator/Totalizer block/25 ms

Additional blocks

1 enhanced Resource block,
 1 custom Pressure with calibration transducer block
 1 custom Advanced Diagnostics transducer block
 including Plugged Input Line Detection
 1 custom Local Display transducer block

Number of link objects

35

Number of VCRs

35

Output interface

FOUNDATION fieldbus digital communication protocol to standard H1, compliant to specification V. 1.7.

Transmitter failure mode

The output signal is “frozen” to the last valid value on gross transmitter failure condition, detected by self-diagnostics which also indicate a BAD conditions. If electronic failure or short circuit occur the transmitter consumption is electronically limited at a defined value (20 mA approx), for safety of the network.

Specification – performance

Stated at reference condition to IEC 60770 ambient temperature of 20 °C (68 °F), relative humidity of 65 %, atmospheric pressure of 1013 hPa (1013 mbar), mounting position with vertical diaphragm and zero based range for transmitter with isolating diaphragms in AISI 316 L ss or Hastelloy and silicone oil fill and HART digital trim values equal to 4 mA and to 20 mA span end points, in linear mode.

Unless otherwise specified, errors are quoted as % of span.

Some performance referring to the Upper Range Limit are affected by the actual turndown (TD) as ratio between Upper Range Limit (URL) and calibrated span.

IT IS RECOMMENDED TO SELECT THE TRANSMITTER SENSOR CODE PROVIDING THE TURNDOWN VALUE AS LOWEST AS POSSIBLE TO OPTIMIZE PERFORMANCE CHARACTERISTICS.

Accuracy rating

% of calibrated span, including combined effects of terminal based linearity, hysteresis and repeatability.

For fieldbus versions SPAN refer to analog input function block outscale range

Model	Sensor	for TD	
266DRH with seal(s) mnemonic P3, F3, E3, S3, F2	F	from 1:1 to 10:1	± 0.06 %
	F	from 10:1 to 60:1	± (0.006 x TD) %
	H to S	from 1:1 to 10:1	± 0.075 %
	H to S	from 10:1 to 60:1	± (0.0075 x TD) %
	E and B	from 1:1 to 5:1	± 0.10 %
266DRH high static with seal(s) mnemonic P3, F3, E3, S3, F2	E and B	from 5:1 to 20:1	± (0.02 x TD) %
	F to Q	from 1:1 to 10:1	± 0.075 %
266DRH with seal(s) mnemonic different from above	F to Q	from 10:1 to 60:1	± (0.0075 x TD) %
	F to S	from 1:1 to 10:1	± 0.10 %
	F to S	from 10:1 to 60:1	± (0.01 x TD) %
	E and B	from 1:1 to 5:1	± 0.15 %
266DRH high static with seal(s) mnemonic different from above	E and B	from 5:1 to 20:1	± (0.03 x TD) %
	F to Q	from 1:1 to 10:1	± 0.10 %
	F to Q	from 10:1 to 60:1	± (0.01 x TD) %

Model	Sensor	for TD	
266HRH with seal mnemonic P3, F3, E3, S3, F2, K1.5	M and P	from 1:1 to 10:1	± 0.06 %
		from 10:1 to 60:1	± (0.006 x TD) %
	F, H, Q, S	from 1:1 to 10:1	± 0.075 %
		from 10:1 to 60:1	± (0.0075 x TD) %
	W	from 1:1 to 5:1	± 0.075 %
		from 5:1 to 50:1	± (0.015 x TD) %
Z	from 1:1 to 5:1	± 0.15 %	
	from 5:1 to 10:1	± (0.03 x TD) %	
266HRH with seal mnemonic Y1	H and M	from 1:1 to 5:1	± 0.15 %
		from 5:1 to 30:1	± (0.03 x TD) %
	P, Q	from 1:1 to 5:1	± 0.075 %
266HRH with seal mnemonic M1	H and M	from 5:1 to 30:1	± (0.015 x TD) %
		from 1:1 to 5:1	± 0.15 %
	P, Q, S	from 5:1 to 30:1	± (0.03 x TD) %
		from 1:1 to 5:1	± 0.075 %
266HRH with seal mnemonic M1.5, M1.5B	F, H, M, P, Q	from 5:1 to 30:1	± (0.015 x TD) %
		from 1:1 to 5:1	± 0.075 %
266HRH with seal mnemonic M1.5A	F, H, M, P, Q, S	from 5:1 to 30:1	± (0.015 x TD) %
		from 1:1 to 5:1	± 0.075 %
266HRH with seal different from above	F, H, M, P, Q, S	from 1:1 to 10:1	± 0.10 %
		from 10:1 to 60:1	± (0.01 x TD) %
	W	from 1:1 to 5:1	± 0.10 %
		from 5:1 to 50:1	± (0.02 x TD) %
Z	from 1:1 to 5:1	± 0.20 %	
	from 5:1 to 10:1	± (0.04 x TD) %	
266NRH with seal mnemonic P3, F3, E3, S3, F2, K1.5	F to S	from 1:1 to 10:1	± 0.10 %
		from 10:1 to 60:1	± (0.01 x TD) %
266NRH with seal mnemonic M1	H and M	from 1:1 to 5:1	± 0.20 %
		from 5:1 to 30:1	± (0.04 x TD) %
	P, Q, S	from 1:1 to 5:1	± 0.10 %
266NRH with seal mnemonic M1.5, M1.5B	F, H, M, P, Q	from 5:1 to 30:1	± (0.02 x TD) %
		from 1:1 to 5:1	± 0.10 %
266NRH with seal mnemonic M1.5A	F, H, M, P, Q, S	from 5:1 to 30:1	± (0.02 x TD) %
		from 1:1 to 5:1	± 0.10 %
266NRH with seal different from above	F to S	from 1:1 to 10:1	± 0.15 %
		from 10:1 to 60:1	± (0.015 x TD) %

Ambient temperature

per 20K change between the limits of -40 °C to +85 °C
(per 36 °F change between the limits of -40 to +185 °F):

Model	Sensor	for TD up to	
266DRH	E to S	10 : 1	± (0.04 % URL + 0.065 % span)
	B	10 : 1	± (0.06 % URL + 0.10 % span)
266HRH	F to W	10 : 1	± (0.04 % URL + 0.065 % span)
	Z	10 : 1	± (0.06 % URL + 0.10 % span)
266NRH	F to S	10 : 1	± (0.08 % URL + 0.13 % span)

REFER TO S26 SEALS ERRORS IN NEXT PAGES FOR
TEMPERATURE ADDITIONAL EFFECTS OF REMOTE/
DIRECT MOUNT SEAL(S)

Static pressure

(zero errors can be calibrated out at line pressure)
per 2 MPa, 20 bar or 290 psi for all sensors except B
with remote seal(s)

- zero error: ±0.25% of URL
- span error: ±0.25% of reading

with direct mount seal only

- zero error: ±0.15% of URL
- span error: ±0.15% of reading

with direct mount plus remote seal

- zero error: ±0.20% of URL
- span error: ±0.20% of reading

per 2 MPa, 20 bar or 290 psi for sensor B only

with remote seal(s) or with direct mount plus remote seal

- zero error: ±0.30% of URL
- span error: ±0.30% of reading

Model 266DRH with direct mount seal only

- zero error: ±0.25% of URL
- span error: ±0.25% of reading

Supply voltage

Within voltage/load specified limits the total effect is less
than 0.005 % of URL per volt.

Load

Within load/voltage specified limits the total effect is
negligible.

Electromagnetic field

Meets all the requirements of EN 61326 for surge
immunity level (of NAMUR NE 21 on request).

Common mode interference

No effect from 100Vrms @ 50Hz, or 50 V DC

...Specification – performance

Seals temperature effects

The following table shows temperature effect per 20 K (36 °F) change, detailed separately for

- the seal (one element), as process temperature error
- the capillary per meter
- the system (transmitter sensor when combined with a seal of specific size/type, either direct mount or remote) referred to silicone oil (PMX 200) filling and AISI 316 L ss diaphragm materials.

For filling different from silicone oil (PMX 200) the errors can be multiplied by ratio between the thermal expansion coefficients of the selected filling divided by the one of PMX 200, listed in the fill fluid characteristics table.

THE ERRORS IN TABLE CAN BE CONSIDERED DIVIDED BY 4 FOR TRANSMITTERS USING SAME REMOTE SEAL ON THE TWO SIDES.

S26RA, S26RE, S26RJ rotating flange seal size - Mnemonic	Sensor URL	Seal error (process)	Direct mount system error (ambient)	Remote mount system error (ambient)	1 metre capillary error (ambient)
2 in. / DN 50 / A50 - P2	40 kPa, 160 inH2O	0.23 kPa, 0.92 inH2O	0.16 kPa, 0.64 inH2O	0.14 kPa, 0.56 inH2O	0.11 kPa, 0.44 inH2O
2 in. / DN 50 / A50 - P2	≥160 kPa, 642 inH2O	0.23 kPa, 0.92 inH2O	0.16 kPa, 0.64 inH2O	0.14 kPa, 0.56 inH2O	0.07 kPa, 0.28 inH2O
2 in. / DN 50 - F2	≥ 4 kPa, 16 inH2O	0.05 kPa, 0.2 inH2O	0.04 kPa, 0.16 inH2O	0.04 kPa, 0.16 inH2O	0.03 kPa, 0.12 inH2O
2 in. / DN 50 - E2	40 kPa, 160 inH2O	0.25 kPa, 1 inH2O	0.21 kPa, 0.84 inH2O	0.20 kPa, 0.80 inH2O	0.15 kPa, 0.60 inH2O
2 in. / DN 50 - E2	≥160 kPa, 642 inH2O	0.25 kPa, 1 inH2O	0.21 kPa, 0.84 inH2O	0.20 kPa, 0.80 inH2O	0.10 kPa, 0.40 inH2O
3 / 4 in. / DN 80 / 100 A80 / 100 - P3	4 - 16 kPa, 16 - 64 inH2O	0.08 kPa, 0.32 inH2O	0.02 kPa, 0.08 inH2O	0.02 kPa, 0.08 inH2O	0.02 kPa, 0.08 inH2O
3 / 4 in. / DN 80 / 100 A80 / 100 - P3	≥ 40 kPa, 160 inH2O	0.08 kPa, 0.32 inH2O	0.02 kPa, 0.08 inH2O	0.02 kPa, 0.08 inH2O	0.03 kPa, 0.12 inH2O
3 / 4 in. / DN 80 / 100 - F3	≥ 4 kPa, 16 inH2O	0.02 kPa, 0.08 inH2O	0.02 kPa, 0.08 inH2O	0.02 kPa, 0.08 inH2O	0.01 kPa, 0.04 inH2O
3 in. / DN 80 - E3	≥ 4 kPa, 16 inH2O	0.14 kPa, 0.56 inH2O	0.05 kPa, 0.20 inH2O	0.05 kPa, 0.20 inH2O	0.04 kPa, 0.16 inH2O

S26RR rotating flange RJ seal size - Mnemonic	Sensor URL	Seal error (process)	Direct mount system error (ambient)	Remote mount system error (ambient)	1 metre capillary error (ambient)
1 1/2 in. - P1.5	≥ 160 kPa, 642 inH2O	0.74 kPa, 3 inH2O	0.67 kPa, 2.68 inH2O	0.62 kPa, 2.48 inH2O	0.31 kPa, 1.24 inH2O
2 in. - P2	40 kPa, 160 inH2O	0.23 kPa, 0.92 inH2O	0.16 kPa, 0.64 inH2O	0.14 kPa, 0.56 inH2O	0.11 kPa, 0.44 inH2O
2 in. - P2	≥160 kPa, 642 inH2O	0.23 kPa, 0.92 inH2O	0.16 kPa, 0.64 inH2O	0.14 kPa, 0.56 inH2O	0.07 kPa, 0.28 inH2O
3 in. - P3	4 - 16 kPa, 16 - 64 inH2O	0.08 kPa, 0.32 inH2O	0.02 kPa, 0.08 inH2O	0.02 kPa, 0.08 inH2O	0.02 kPa, 0.08 inH2O
3 in. - P3	≥ 40 kPa, 160 inH2O	0.08 kPa, 0.32 inH2O	0.02 kPa, 0.08 inH2O	0.02 kPa, 0.08 inH2O	0.03 kPa, 0.12 inH2O

S26RH rotating flange ISO seal size - Mnemonic	Sensor URL	Seal error (process)	Direct mount system error (ambient)	Remote mount system error (ambient)	1 metre capillary error (ambient)
1 13/16 in. - H1.5	≥ 70000 kPa, 10150 psi	0.74 kPa, 3 inH2O	0.67 kPa, 2.68 inH2O	0.62 kPa, 2.48 inH2O	0.31 kPa, 1.24 inH2O
2 1/16 in. - P1.5	≥ 70000 kPa, 10150 psi	0.64 kPa, 2.56 inH2O	1.25 kPa, 5.0 inH2O	1.14 kPa, 0.08 inH2O	0.38 kPa, 1.52 inH2O

S26FA, S26FE fixed flange seal size - Mnemonic	Sensor URL	Seal error (process)	Direct mount system error (ambient)	Remote mount system error (ambient)	1 metre capillary error (ambient)
2 in. / DN 50 - P2	40 kPa, 160 inH2O	0.23 kPa, 0.92 inH2O	0.16 kPa, 0.64 inH2O	0.14 kPa, 0.56 inH2O	0.11 kPa, 0.44 inH2O
2 in. / DN 50 - P2	≥160 kPa, 642 inH2O	0.23 kPa, 0.92 inH2O	0.16 kPa, 0.64 inH2O	0.14 kPa, 0.56 inH2O	0.07 kPa, 0.28 inH2O
2 in. / DN 50 - F2	≥ 4 kPa, 16 inH2O	0.05 kPa, 0.2 inH2O	0.04 kPa, 0.16 inH2O	0.04 kPa, 0.16 inH2O	0.03 kPa, 0.12 inH2O
3 / 4 in. / DN 80 / 100 - P3	4 - 16 kPa, 16 - 64 inH2O	0.08 kPa, 0.32 inH2O	0.02 kPa, 0.08 inH2O	0.02 kPa, 0.08 inH2O	0.02 kPa, 0.08 inH2O
3 / 4 in. / DN 80 / 100 - P3	≥ 40 kPa, 160 inH2O	0.08 kPa, 0.32 inH2O	0.02 kPa, 0.08 inH2O	0.02 kPa, 0.08 inH2O	0.03 kPa, 0.12 inH2O
3 / 4 in. / DN 80 / 100 - F3	≥ 4 kPa, 16 inH2O	0.02 kPa, 0.08 inH2O	0.02 kPa, 0.08 inH2O	0.02 kPa, 0.08 inH2O	0.01 kPa, 0.04 inH2O

S26MA, S26ME off-line flange seal size - Mnemonic	Sensor URL	Seal error (process)	Direct mount system error (ambient)	Remote system error (ambient)	1 metre capillary error (ambient)
2 1/2 in. - T2.5	≥ 4 kPa, 16 inH2O	0.26 kPa, 1.04 inH2O	0.11 kPa, 0.44 inH2O	0.1 kPa, 0.4 inH2O	0.08 kPa, 0.32 inH2O

S26TT off-line threaded seal size - Mnemonic	Sensor URL	Seal error (process)	Direct mount system error (ambient)	Remote system error (ambient)	1 metre capillary error (ambient)
2 1/2 in. - T2.5	≥ 4 kPa, 16 inH2O	0.26 kPa, 1.04 inH2O	0.11 kPa, 0.44 inH2O	0.1 kPa, 0.4 inH2O	0.08 kPa, 0.32 inH2O

S26SS sanitary and food seal size - Mnemonic	Sensor URL	Seal error (process)	Direct mount system error (ambient)	Remote system error (ambient)	1 metre capillary error (ambient)
2 in. / F50 - S2	40 kPa, 160 inH2O	0.7 kPa, 2.8 inH2O	0.93 kPa, 3.72 inH2O	0.87 kPa, 3.48 inH2O	0.68 kPa, 2.72 inH2O
2 in. / F50 - S2	≥160 kPa, 642 inH2O	0.7 kPa, 2.8 inH2O	0.93 kPa, 3.72 inH2O	0.87 kPa, 3.48 inH2O	0.44 kPa, 1.76 inH2O
2 in. - S2.5	40 kPa, 160 inH2O	0.16 kPa, 0.64 inH2O	0.19 kPa, 0.76 inH2O	0.18 kPa, 0.72 inH2O	0.14 kPa, 0.56 inH2O
2 in. - S2.5	≥160 kPa, 642 inH2O	0.16 kPa, 0.64 inH2O	0.19 kPa, 0.76 inH2O	0.18 kPa, 0.72 inH2O	0.09 kPa, 0.36 inH2O
3 / 4 in. / F80 - S3	4 - 16 kPa, 16 - 64 inH2O	0.06 kPa, 0.24 inH2O	0.02 kPa, 0.08 inH2O	0.02 kPa, 0.08 inH2O	0.01 kPa, 0.04 inH2O
3 / 4 in. / F80 - S3	≥ 40 kPa, 160 inH2O	0.06 kPa, 0.24 inH2O	0.02 kPa, 0.08 inH2O	0.02 kPa, 0.08 inH2O	0.03 kPa, 0.12 inH2O
3 / 4 in. - S3.5	4 - 16 kPa, 16 - 64 inH2O	0.04 kPa, 0.16 inH2O	0.02 kPa, 0.08 inH2O	0.02 kPa, 0.08 inH2O	0.01 kPa, 0.04 inH2O
3 / 4 in. - S3.5	≥ 40 kPa, 160 inH2O	0.04 kPa, 0.16 inH2O	0.02 kPa, 0.08 inH2O	0.02 kPa, 0.08 inH2O	0.03 kPa, 0.12 inH2O
1 1/2 in. - K1.5	≥ 40 kPa, 260 inH2O	0.2 kPa, 0.8 inH2O	0.5 kPa, 2 inH2O	NA	NA

S26VN saddle & socket seal size - Mnemonic	Sensor URL	Seal error (process)	Direct mount system error (ambient)	Remote mount error (ambient)	1 metre capillary error (ambient)
1 1/2 in. - P1.5	≥ 160 kPa, 642 inH2O	0.74 kPa, 3 inH2O	0.67 kPa, 2.68 inH2O	0.62 kPa, 2.48 inH2O	0.31 kPa, 1.24 inH2O

S26WA, S26WE wafer seal size - Mnemonic	Sensor URL	Seal error (process)	Remote mount error (ambient)	1 metre capillary error (ambient)
1 1/2 in. / DN 40 - P1.5	≥ 160 kPa, 642 inH2O	0.74 kPa, 3 inH2O	0.62 kPa, 2.48 inH2O	0.31 kPa, 1.24 inH2O
1 1/2 in. / DN 40 - F1.5	≥ 160 kPa, 642 inH2O	0.15 kPa, 0.6 inH2O	0.15 kPa, 0.6 inH2O	0.08 kPa, 0.32 inH2O
2 in. / DN 50 - P2	40 kPa, 160 inH2O	0.23 kPa, 0.92 inH2O	0.14 kPa, 0.56 inH2O	0.11 kPa, 0.44 inH2O
2 in. / DN 50 - P2	≥160 kPa, 642 inH2O	0.23 kPa, 0.92 inH2O	0.14 kPa, 0.56 inH2O	0.07 kPa, 0.28 inH2O
2 in. / DN 50 - F2	≥ 4 kPa, 16 inH2O	0.05 kPa, 0.2 inH2O	0.04 kPa, 0.16 inH2O	0.03 kPa, 0.12 inH2O
3 in. / DN 80 - P3	4 - 16 kPa, 16 - 64 inH2O	0.08 kPa, 0.32 inH2O	0.02 kPa, 0.08 inH2O	0.02 kPa, 0.08 inH2O
3 in. / DN 80 - P3	≥ 40 kPa, 160 inH2O	0.08 kPa, 0.32 inH2O	0.02 kPa, 0.08 inH2O	0.03 kPa, 0.12 inH2O
3 in. / DN 80 - F3	≥ 4 kPa, 16 inH2O	0.02 kPa, 0.08 inH2O	0.02 kPa, 0.08 inH2O	0.01 kPa, 0.04 inH2O

S26CN Chemical Tee seal size - Mnemonic	Sensor URL	Seal error (process)	Remote system error (ambient)	1 metre capillary error (ambient)
3 in. - P3	4 - 16 kPa, 16 - 64 inH2O	0.08 kPa, 0.32 inH2O	0.02 kPa, 0.08 inH2O	0.02 kPa, 0.08 inH2O
3 in. - P3	≥ 40 kPa, 160 inH2O	0.08 kPa, 0.32 inH2O	0.02 kPa, 0.08 inH2O	0.03 kPa, 0.12 inH2O

S26BN Button type seal size - Mnemonic	Sensor URL	Seal error (process)	Remote system error (ambient)	1 metre capillary error (ambient)
1 in. - B1	≥ 8 MPa, 1160 psi	1.3 kPa, 5.2 inH2O	6.5 kPa, 26 inH2O	1.9 kPa, 7.6 inH2O

S26UN Union connection seal size - Mnemonic	Sensor URL	Seal error (process)	Remote system error (ambient)	1 metre capillary error (ambient)
1 1/2 in. - Z1.5	≥ 160 kPa, 642 inH2O	0.29 kPa, 1.16 inH2O	0.62 kPa, 2.48 inH2O	0.31 kPa, 1.24 inH2O

S26PN urea service seal size - Mnemonic	Sensor URL	Seal error (process)	Remote system error (ambient)	1 metre capillary error (ambient)
1 1/2 in. - U1.5 (2 in. flange)	≥ 160 kPa, 642 inH2O	0.86 kPa, 3.44 inH2O	1.1 kPa, 4.4 inH2O	0.54 kPa, 2.16 inH2O
2 1/2 in. - U2.5 (3 in. flange)	≥ 40 kPa, 160 inH2O	0.18 kPa, 0.72 inH2O	0.06 kPa, 0.24 inH2O	0.11 kPa, 0.44 inH2O

S26JN in-line seal size - Mnemonic	Sensor URL	Seal error (process)	Direct mount error (ambient)
1 in. - J1	≥ 600 kPa, 87 psi	2.2 kPa, 8.8 inH2O	0.94 kPa, 3.76 inH2O
1 1/2 in. - J1.5	≥ 600 kPa, 87 psi	1.4 kPa, 5.6 inH2O	0.36 kPa, 1.44 inH2O
2 in. - J2	≥ 600 kPa, 87 psi	4.6 kPa, 18.4 inH2O	0.94 kPa, 3.76 inH2O
4 in. - J3	≥ 600 kPa, 87 psi	3.0 kPa, 12 inH2O	0.42 kPa, 1.68 inH2O

S26KN paper seal size - Mnemonic	Sensor URL	Seal error (process)	Direct mount error (ambient)
1 in. - Y1	≥ 160 kPa, 642 inH2O	1.2 kPa, 4.8 inH2O	0.64 kPa, 2.56 inH2O
1 in. - M1	≥ 160 kPa, 642 inH2O	0.6 kPa, 2.4 inH2O	0.64 kPa, 2.56 inH2O
1 1/2 in. M1.5 - M1.5A - M1.5B	≥ 40 kPa, 160 inH2O	0.2 kPa, 0.8 inH2O	0.48 kPa, 1.92 inH2O

Specification – physical

(Refer to ordering information pages for variant availability related to specific model or versions code)

Model 266DRH only - materials of side without seal

Process isolating diaphragms (*)

AISI 316 L ss; Hastelloy® C-276; Monel 400®; Tantalum.
A remote seal can be selected with required diaphragm material (refer to high pressure side).

Process flanges, adapters, plugs and drain/vent valves (*)

AISI 316 L ss (1); Hastelloy® C-276 (2); Monel 400® (3).

Bolts and nuts

AISI 316 ss bolts Class A4–80 and nuts Class A4-70 per ISO 3506;
AISI 316 ss bolts and nuts Class A4–50 per ISO 3506, in compliance with NACE MR0175 Class II (std. static only).
Stainless steel per ASTM-A-453 grade 660D, in compliance with NACE MR0175 Class II (high static only).

Gaskets (*)

Viton®; PTFE.

Model 266DRH, 266HRH, 266NRH materials

Seal side process diaphragm (remote/direct mount seal) (*)

AISI 316 L ss; Hastelloy® C-276; Hastelloy® C-2000;
Inconel 625; Tantalum; AISI 316 L ss gold plated;
AISI 316 L ss or Hastelloy® C-276 with anti-stick coating;
AISI 316 L ss with anti-corrosion coating;
Superduplex ss (UNS S32750 to ASTM SA479);
Diaflex (AISI with anti-abrasion treatment).

Extension material (*)

AISI 316 L ss (also for Diaflex and gold plated diaphragms);
Hastelloy® C-276; AISI 316 L ss or Hastelloy® C-276 with coating same as diaphragm

Seal side fill fluid

Silicone oil-PMX 200®; Silicone oil for high temperature;
Low viscosity silicone oil-Baysilone® M5; Inert-Galden®;
Inert-Halocarbon® 4.2; Silicone Polymer-Syltherm XLT®;
Glycerin Water; Vegetable oil-Neobee® M-20;
Mineral oil-Esso Marcol 152®.

Electronic housing and covers

Aluminium alloy (copper content $\leq 0.3\%$) with baked epoxy finish (colour RAL9002); AISI 316 L ss.

Covers O-ring

Buna N.

Local adjustments (zero, span and write protect)

For Standard HART version:

- Internal for zero and span (on connection board)
- External non-intrusive for zero, span and write protect in glass filled polyphenylene oxyde, removable (code R1).

For all other versions:

- External non-intrusive for zero, span and write protect in glass filled polyphenylene oxyde, removable.

Plates

Transmitter nameplate: AISI 316 ss screwed to the electronics housing.

Certification plate and optional tag/calibration plate : self-adhesive attached to the electronics housing or AISI 316 ss fastened to the electronics housing with rivets or screws.

Optional wired-on customer data plate: AISI 316 ss. Laser printing on metal or thermal printing on self-adhesive.

For AISI 316 L ss housing it is mandatory to select option I2 or I3 for plates in AISI 316 ss.

Calibration

Standard: at maximum span, zero based range, ambient temperature and pressure;

Optional: at specified range and ambient conditions.

(*) Wetted parts of the transmitter.

(**) U-bolt material: high-strength alloy steel or AISI 316 L ss;
bolts/nuts material: high-strength alloy steel or AISI 316 ss.

(1) Supplied as AISI 316 L or as ASTM A351 Grade CF-3M

(2) Supplied as Hastelloy C-276 or as ASTM A494 alloy CW-12MW

(3) Supplied as Monel 400 or as ASTM A494 Grade M-35-1

Optional extras

Mounting brackets (code Bx)

For vertical and horizontal 60mm. (2in) pipes or wall mounting.

Display (code Lx)

4-position (at 90°) user orientable, except "LS".

Optional plates (code Ix)

Code I2: AISI 316 ss plate with laser printed tag (up to 31 characters) and calibration details (up to 31 characters: lower and upper range values and engineering unit) fixed onto transmitter housing.

Code I1: AISI 316 ss wired-on plate with laser printed customized data (4 lines of 32 characters with 4 mm/0.16 in. height).

Surge protection (code S2)

Test Certificates (test, design, calibration, material traceability) (codes Cx and Hx)

Tag and manual language (codes Tx and Mx)

Process connections 266DRH only - side without seal

on conventional flanges : 1/4 in. – 18 NPT on process axis
on adapters : 1/2 in. – 14 NPT on process axis
fixing threads: 7/16 in. – 20 UNF at 41.3mm centre distance

Refer to S26 seal data sheet for process connection variants through remote seal.

Gasket seat finish for seals

Smooth (polished finish for ASME or EN): 0.8 µm (Ra)
Serrated (to ASME 16.5 flange standard): 3.2 to 6.3 µm (Ra)
Serrated (to EN 1092-1 Type B1): 3.2 to 12.5 µm (Ra)
Serrated (to EN 1092-1 Type D and E): according to standard

(*) Bolts and nuts, gasket and mating flange supplied by customer.

Electrical connections

Two 1/2 in. – 14 NPT or M20x1.5 threaded conduit entries, direct on housing. Only M20x1.5 for WirelessHART with one port used for antenna.

One certified stainless steel plug (supplied loose with thread according to housing entries) available as option.

Terminal block

HART version: three terminals for signal/external meter wiring up to 2.5 mm² (14 AWG), also connection points for test and communication purposes.

WirelessHART version: connection points for test and communication purposes; additional fast connection for external harvesting unit.

Fieldbus versions: two terminals for signal wiring (bus connection) up to 2.5 mm² (14 AWG)

Grounding

Internal and external 6 mm² (10 AWG) ground termination points are provided.

Mounting position

Transmitter can be mounted in any position.

Electronics housing may be rotated to any position.

A positive stop prevents over travel.

Mass (without options and seals)

models 266DRH: 4 kg approx (8.8 lb)

models 266HRH, 266NRH: 2 kg approx (4.4 lb)

Add 1.5 kg (3.4 lb) for AISI housing.

Add 650 g (1.5 lb) for packing.

Consider additional weight up to 50 kg (up to 110 lb) for seals.

Packing

Carton.

Specification – configuration

Transmitter with HART communication and 4 to 20 mA

Standard configuration

Transmitters are factory calibrated to customer's specified range. Calibrated range and tag number are stamped on the tag plate. If a calibration range and tag data are not specified, the transmitter will be supplied with the plate left blank and configured as follows:

Engineering Unit	kPa
4 mA	Zero
20 mA	Upper Range Limit (URL)
Output	Linear
Damping	1 s
Transmitter failure mode	Upscale
Software tag (8 char. max)	Blank
Optional LCD display	PV in kPa; output in mA and in percentage on bargraph

Any or all the above configurable parameters, including Lower range-value and Upper range-value which must be the same unit of measure, can be easily changed using the HART hand-held communicator or by a PC running the configuration software with DTM for 266 models. The transmitter database is customized with specified flange type and material, O-ring and drain/vent materials and meter code option.

Custom configuration (option N6)

The following data may be specified in addition to the standard configuration parameters:

Descriptor	16 alphanumeric characters
Message	32 alphanumeric characters
Date	Day, month, year

For HART protocol available engineering units of pressure measure are :

- Pa, kPa, MPa
- inH2O@4 °C, mmH2O@4 °C, psi
- inH2O@68 °F, ftH2O@68 °F, mmH2O@68 °F
- inHg, mmHg, Torr
- g/cm², kg/cm², atm
- mbar, bar

These and others are available for PROFIBUS and FOUNDATION Fieldbus.

Transmitter with WirelessHART communication

Standard configuration

Transmitters are factory calibrated to customer's specified range. Calibrated range and tag number are stamped on the tag plate. If a calibration range and tag data are not specified, the transmitter will be supplied with the plate left blank and configured as follows:

Engineering Unit	kPa
Output scale 0 %	Lower Range Limit (LRL)
Output scale 100 %	Upper Range Limit (URL)
Output	Linear
Update time	16 s
Software tag (8 char. max)	Blank
Optional LCD display	PV in kPa; output in percentage on bargraph

Any or all the above configurable parameters, including Lower range-value and Upper range-value which must be the same unit of measure, can be easily changed using the HART hand-held communicator or by a PC running the configuration software with DTM for 266 models. The transmitter database is customized with specified flange type and material, O-ring and drain/vent materials and meter code option.

Custom configuration (option N6)

The following data may be specified in addition to the standard configuration parameters:

Descriptor	16 alphanumeric characters
Message	32 alphanumeric characters
Date	Day, month, year

Transmitter with PROFIBUS PA communication

Standard configuration

Transmitters are factory calibrated to customer's specified range. Calibrated range and tag number are stamped on the tag plate. If a calibration range and tag data are not specified, the transmitter will be supplied with the plate left blank and configured as follows:

Measure Profile	Pressure
Engineering Unit	kPa
Output scale 0 %	Lower Range Limit (LRL)
Output scale 100 %	Upper Range Limit (URL)
Output	Linear
Hi-Hi Limit	Upper Range Limit (URL)
Hi Limit	Upper Range Limit (URL)
Low Limit	Lower Range Limit (LRL)
Low-Low Limit	Lower Range Limit (LRL)
Limits hysteresis	0.5 % of output scale
PV filter	0 s
Address (set by local key)	126
Tag	32 alphanumeric characters
Optional LCD display	PV in kPa; output in percentage on bargraph

Any or all the above configurable parameters, including the range values which must be the same unit of measure, can be easily changed by a PC running the configuration software with DTM for 266 models. The transmitter database is customized with specified flange type and material, O-ring and drain/vent materials and meter code option.

Custom configuration (option N6)

The following data may be specified in addition to the standard configuration parameters:

Descriptor	32 alphanumeric characters
Message	32 alphanumeric characters
Date	Day, month, year

Transmitter with FOUNDATION Fieldbus communication

Standard configuration

Transmitters are factory calibrated to customer's specified range. Calibrated range and tag number are stamped on the tag plate. If a calibration range and tag data are not specified, the transmitter will be supplied with the plate left blank and the analog input function block FB1 is configured as follows:

Measure Profile	Pressure
Engineering Unit	kPa
Output scale 0 %	Lower Range Limit (LRL)
Output scale 100 %	Upper Range Limit (URL)
Output	Linear
Hi-Hi Limit	Upper Range Limit (URL)
Hi Limit :	Upper Range Limit (URL)
Low Limit	Lower Range Limit (LRL) Low-
Low Limit	Lower Range Limit (LRL)
Limits hysteresis	0.5 % of output scale
PV filter time	0 s
Tag	32 alphanumeric characters
Optional LCD display	PV in kPa; output in percentage on bargraph

The analog input function block FB2 and FB3 are configured respectively for the sensor temperature measured in °C and for the static pressure measured in MPa.

Any or all the above configurable parameters, including the range values, can be changed using any host compliant to FOUNDATION fieldbus. The transmitter database is customized with specified flange type and material, O-ring and drain/vent materials and meter code option.

Custom configuration (option N6)

The following data may be specified in addition to the standard configuration parameters:

Descriptor	32 alphanumeric characters
Message	32 alphanumeric characters
Date	Day, month, year

Dimensions

(not for construction unless certified) – dimensions in mm. (in.)

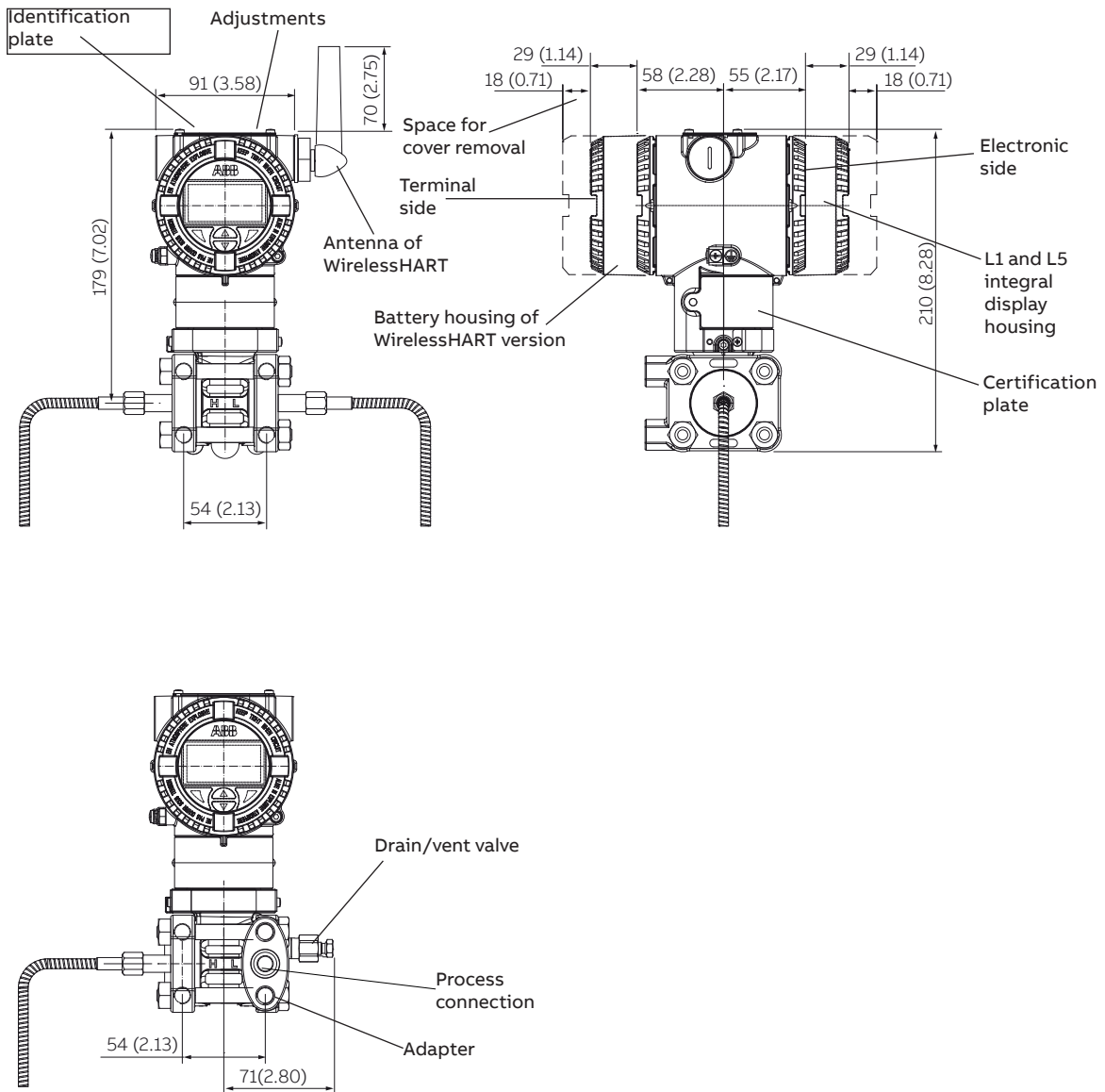

Figure 1 266DRH with barrel housing and remote seal(s)

NOTE

For 266DRH using one seal only, the threaded connection (1/4 in. – 18 NPT direct or 1/2 in. – 14 NPT through adapter) of conventional flange, gasket groove and gaskets are in accordance with IEC 61518.

Bolting threads for fixing adapter or other devices (i.e. manifold etc.) on process flange is 7/16 – 20 UNF.

Negative side of gauge measurement version 266DSHxP is provided with a removable filter, granting protection to the atmospheric pressure reference.

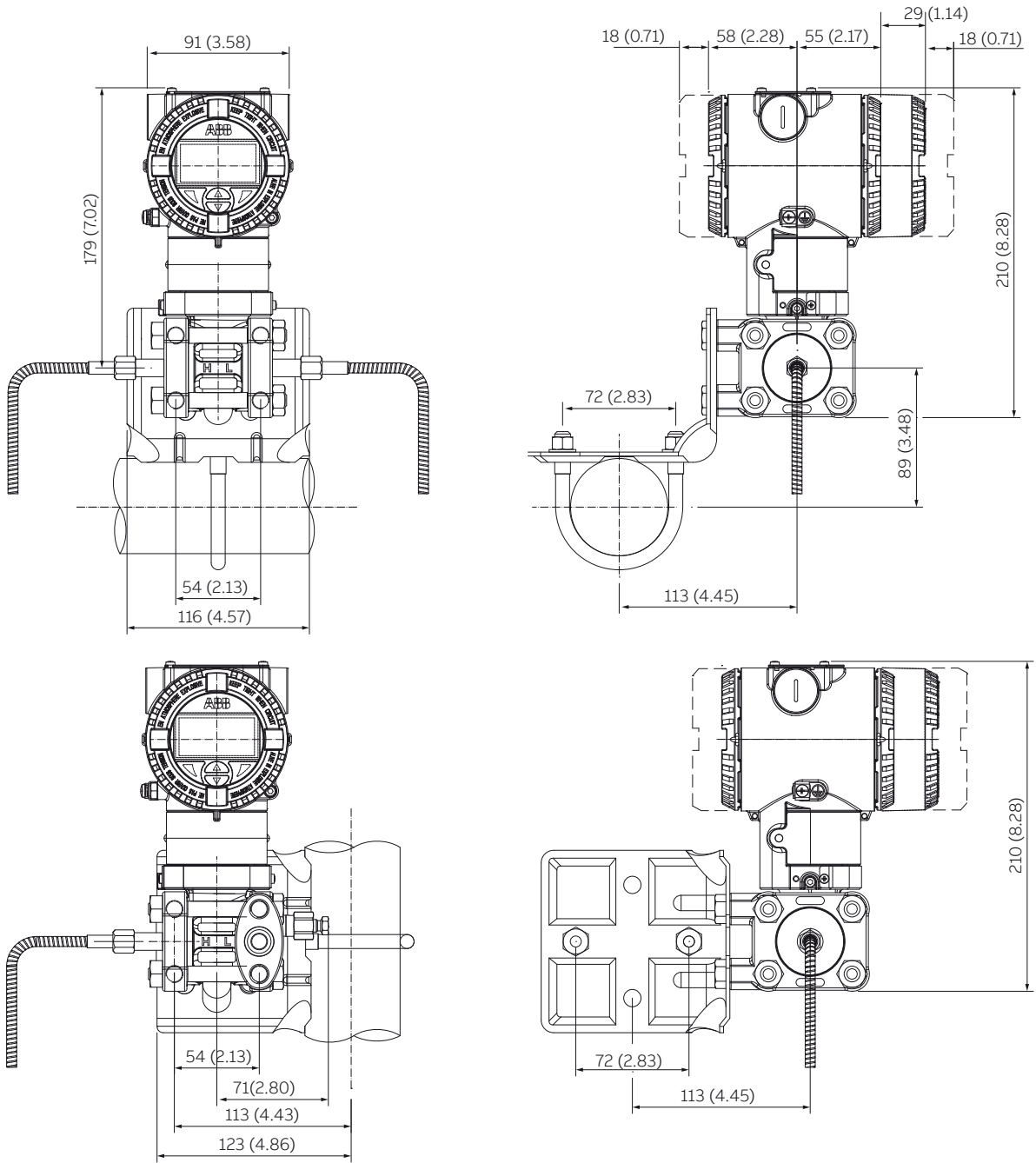

Figure 2 266DRH with barrel housing and remote seal(s) on bracket for vertical or horizontal 60 mm. (2 in.) pipe

...Dimensions

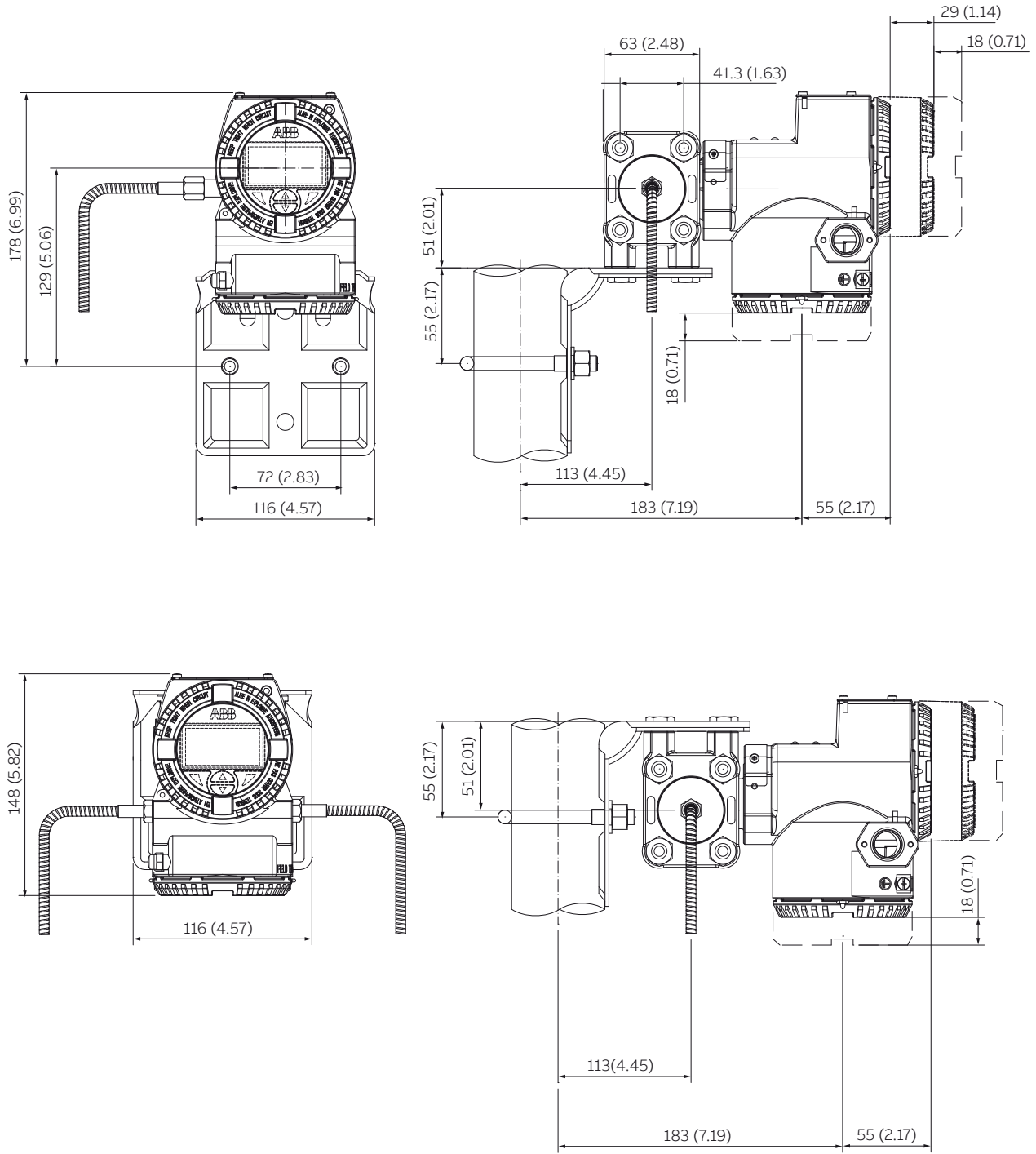

Figure 3 266DRH with DIN housing and remote seal(s) on bracket for vertical or horizontal 60 mm. (2 in.) pipe

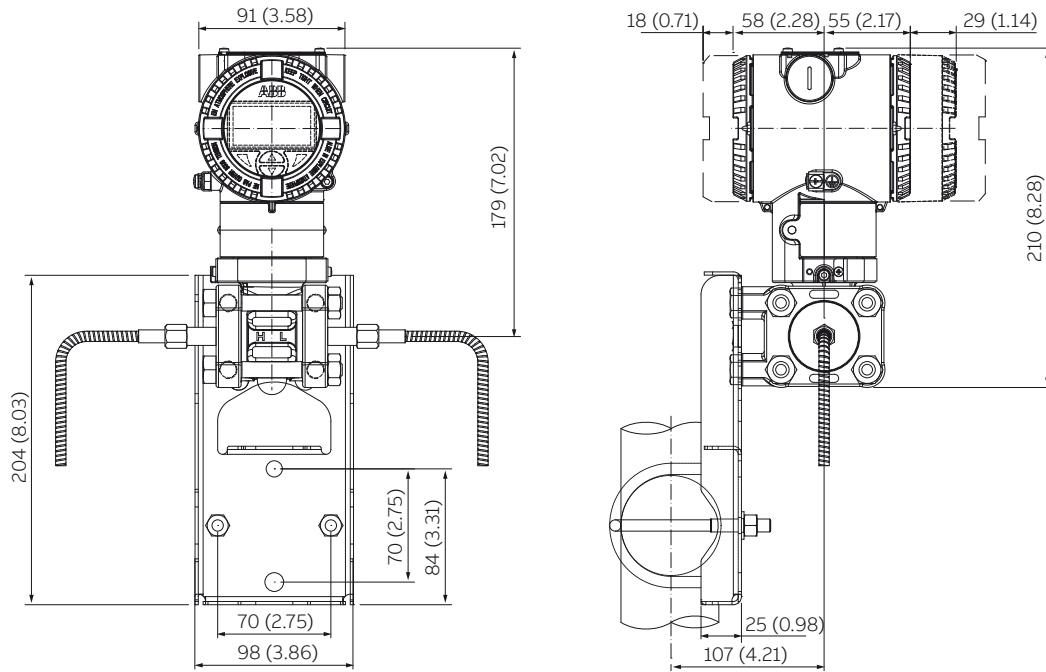

Figure 4 266DRH with barrel housing and remote seal(s) on flat bracket for vertical or horizontal 60 mm. (2 in.) pipe

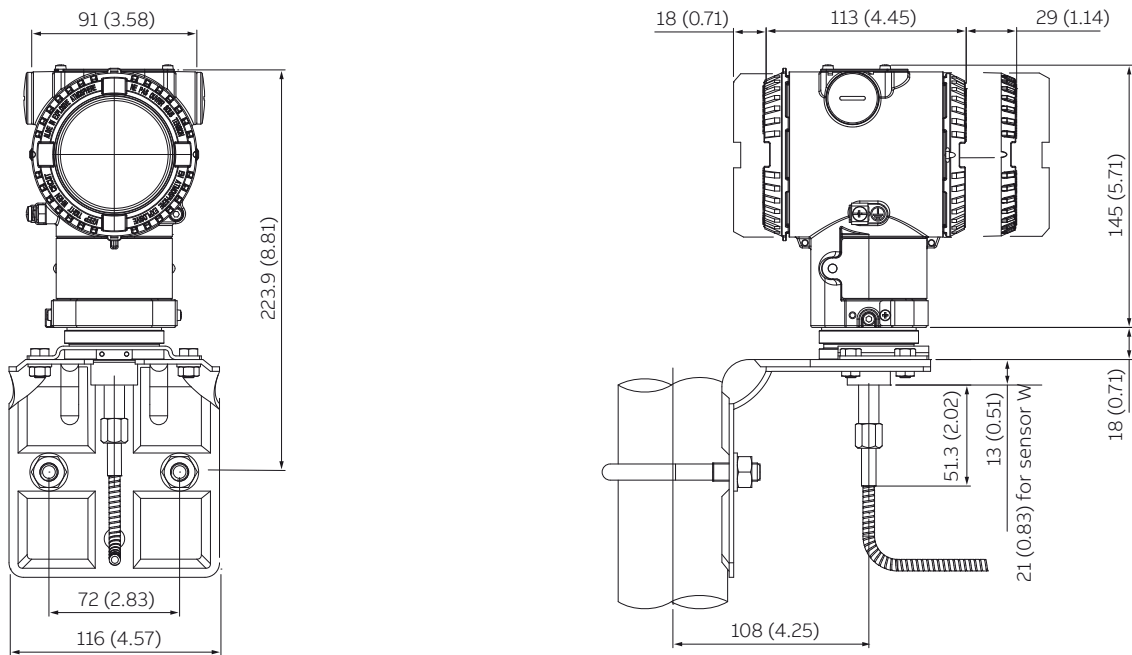

Figure 5 266HRH, 266NRH with barrel housing and remote seal(s) on bracket for vertical or horizontal 60 mm. (2 in.) pipe sensors F, H, M, P, Q, S, W

...Dimensions

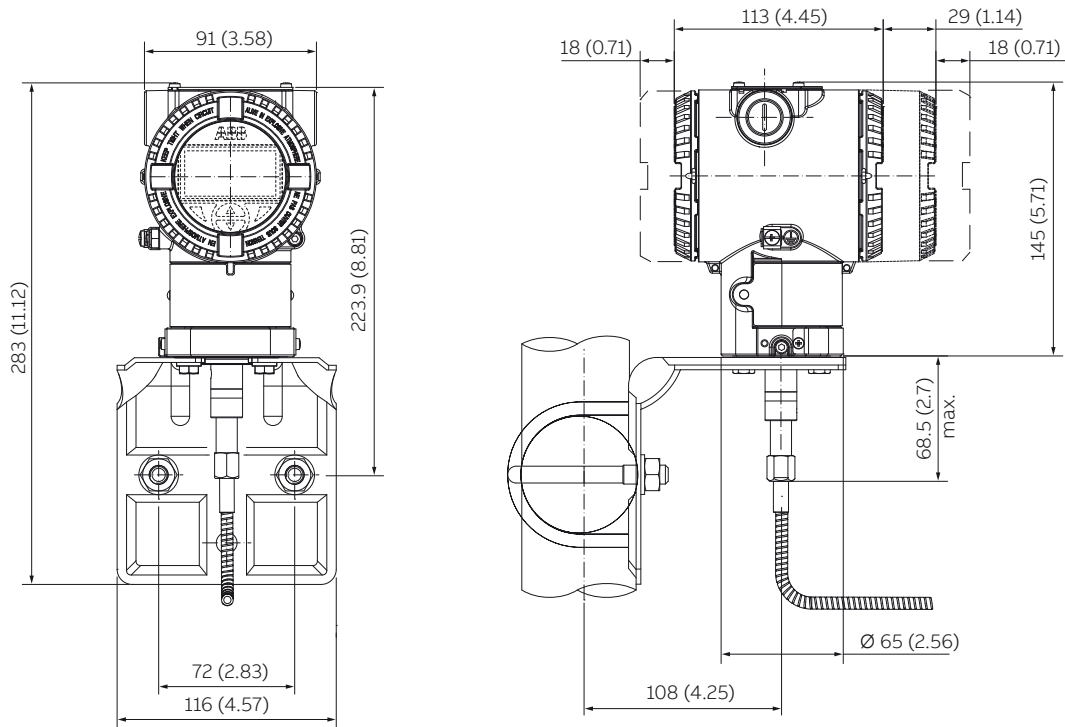

Figure 6 266HRH, 266NRH with barrel housing and remote seal(s) on bracket for vertical or horizontal 60 mm. (2 in.) pipe sensors Z

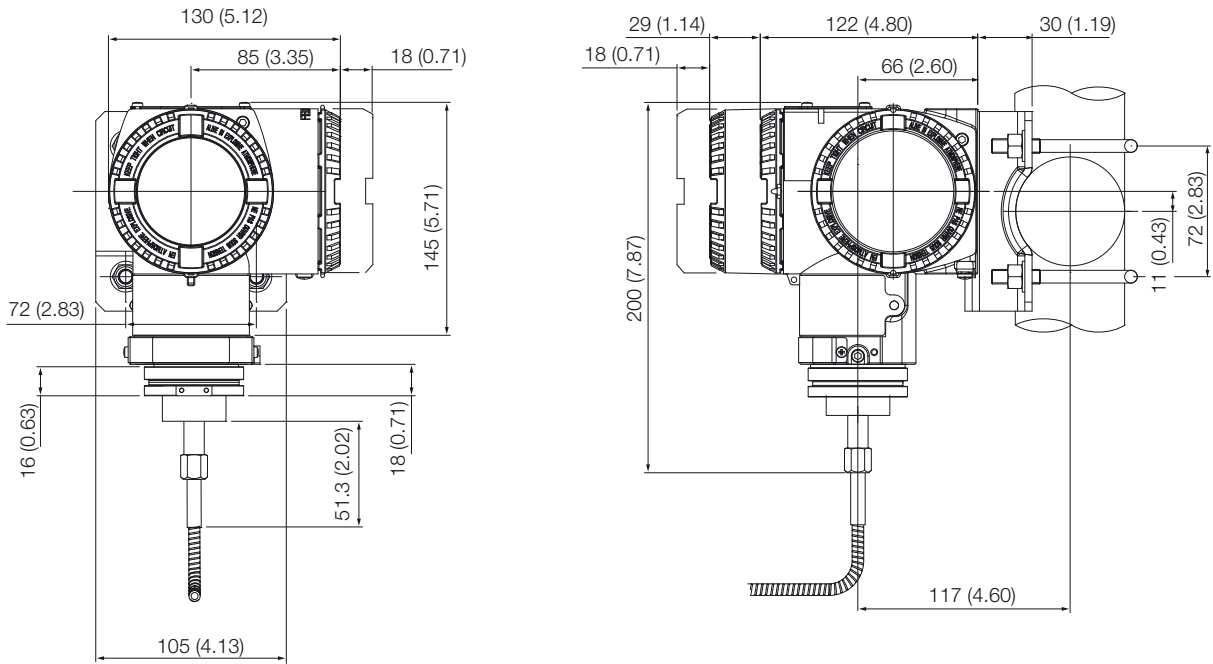

Figure 7 266HRH, 266NRH with DIN housing and remote seal(s) on bracket for vertical or horizontal 60 mm. (2 in.) pipe sensors F, H, M, P, Q, S, W

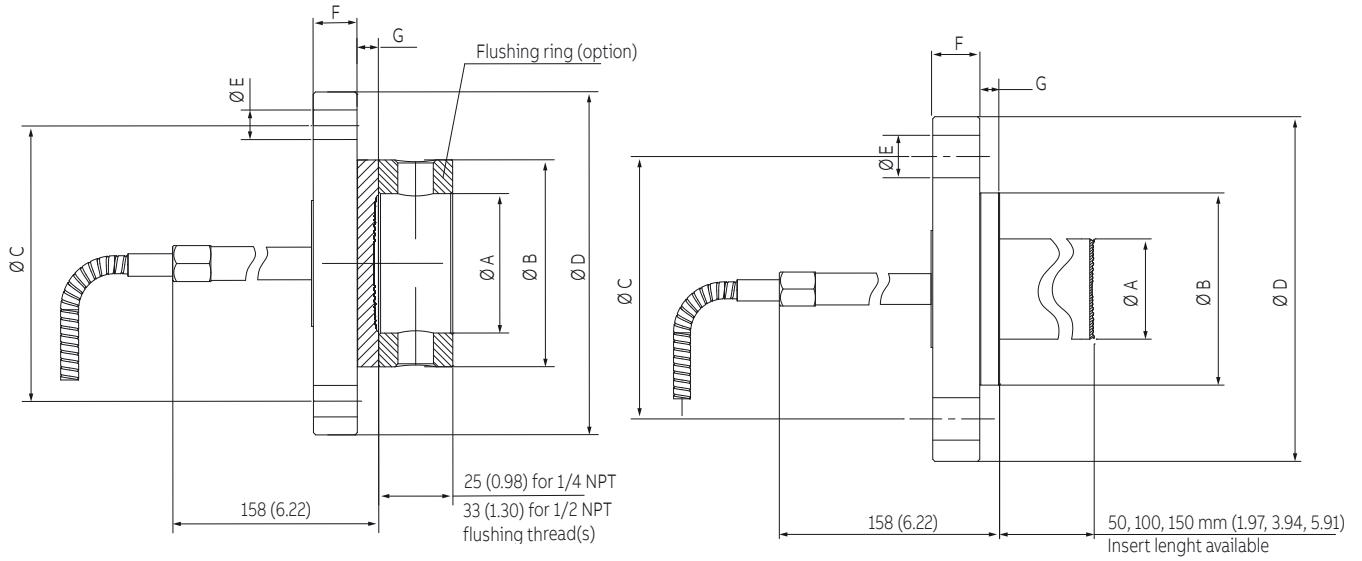

Figure 8 S26RA, S26RE, S26RJ Rotating flange diaphragm seals (flush and extended)

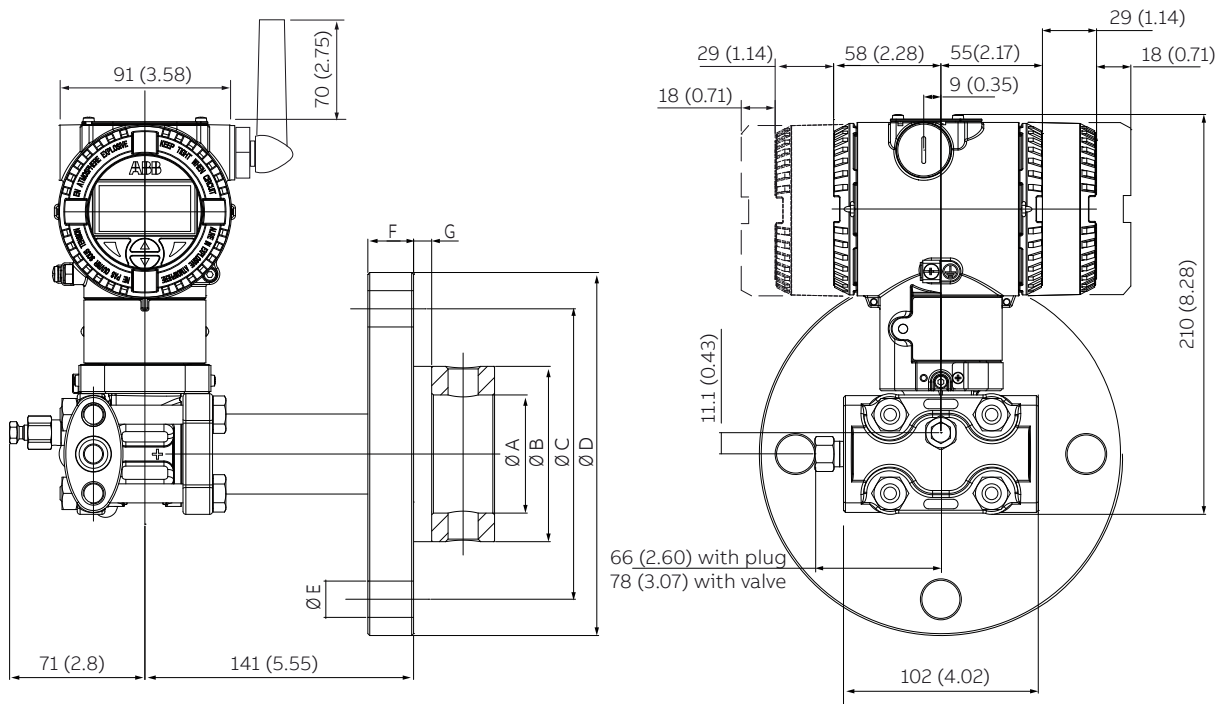

Figure 9 266DRH with barrel housing and direct mount seal S26RA/S26RE/S26RJ rotating flange Raised Face flush diaphragm

...Dimensions

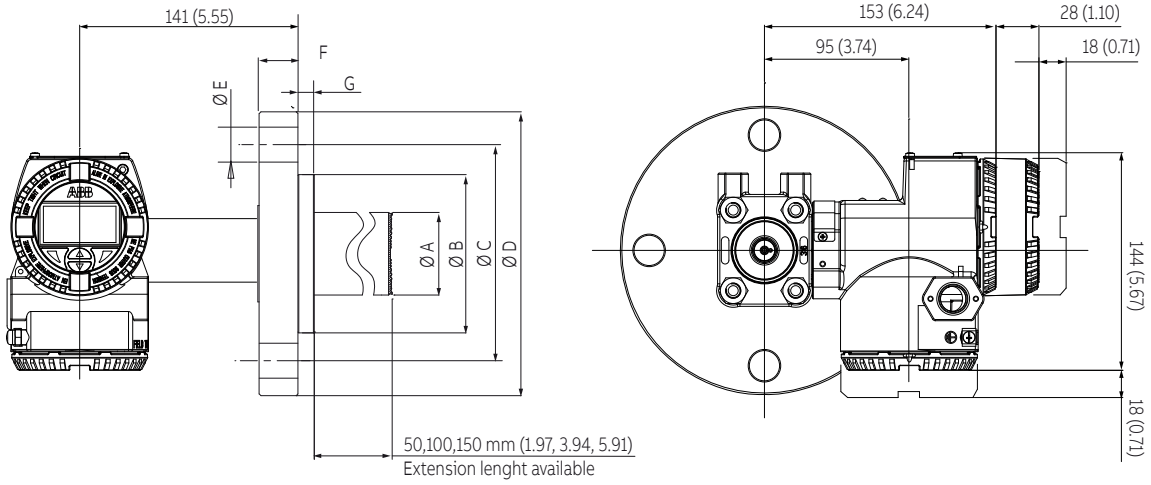

Figure 10 266DRH with DIN housing and direct mount seal S26RA/S26RE/S26RJ rotating flange Raised Face extended diaphragm

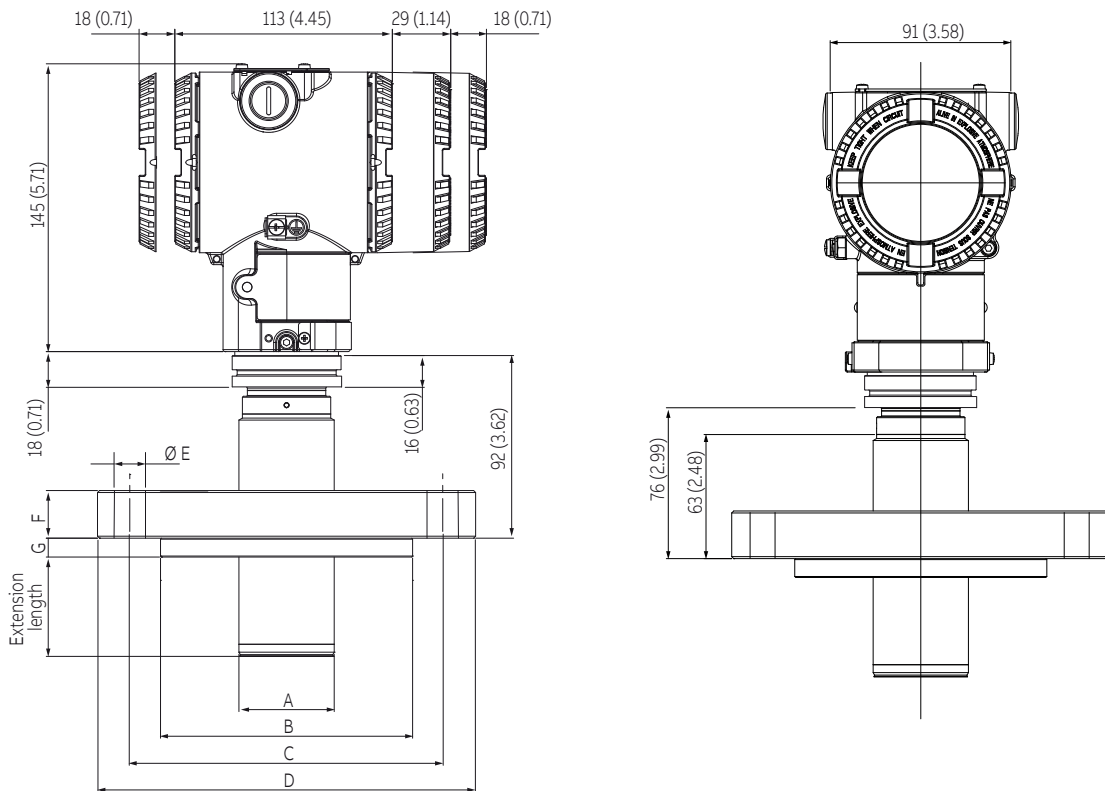

Figure 11 266HRH/266NRH with barrel housing and direct mount seal S26RA/S26RE/S26RJ flanged Raised Face extended diaphragm

Dimensions mm. (in.) for S26RA											
Size/Rating	A (dia)				B (dia)	C (dia)	D (dia)	E (dia)	F (Note 1)	G	N° of holes
	extended diaphragm	flush diaphragm		flushing ring internal dia							
		std.	low thick.								
2 in. ASME CL 150	48 (1.9)	60 (2.36)	58 (2.28)	62 (2.44)	92 (3.62)	120.65 (4.75)	152.4 (6)	19.1 (0.79)	17.5 (0.6)	9.5 (0.37)	4
2 in. ASME CL 300	48 (1.9)	60 (2.36)	58 (2.28)	62 (2.44)	92 (3.62)	127 (5)	165.1 (6.5)	19.1 (0.79)	20.8 (0.8)	9.5 (0.37)	8
2 in. ASME CL 600	NA	60 (2.36)	58 (2.28)	62 (2.44)	92 (3.62)	127 (5)	165.1 (6.5)	19.1 (0.79)	25.4 (1)	9.5 (0.37)	8
2 in. ASME CL 900	NA	60 (2.36)	58 (2.28)	62 (2.44)	92 (3.62)	165 (6.5)	215.9 (8.5)	26 (1.02)	38.1 (1.5)	9.5 (0.37)	8
2 in. ASME CL 1500	NA	60 (2.36)	58 (2.28)	62 (2.44)	92 (3.62)	165 (6.5)	215.9 (8.5)	26 (1.02)	38.1 (1.5)	9.5 (0.37)	8
3 in. ASME CL 150	72 (2.83)	89 (3.5)	75 (2.95)	92 (3.62)	127 (5)	152.4 (6)	190.5 (7.5)	19.1 (0.79)	22.4 (0.88)	9.5 (0.37)	4
3 in. ASME CL 300	72 (2.83)	89 (3.5)	75 (2.95)	92 (3.62)	127 (5)	168.15 (6.62)	209.6 (8.25)	22.4 (0.88)	26.9 (1.1)	9.5 (0.37)	8
3 in. ASME CL 600	NA	89 (3.5)	75 (2.95)	92 (3.62)	127 (5)	168.15 (6.62)	209.6 (8.25)	22.4 (0.88)	31.8 (1.3)	9.5 (0.37)	8
3 in. ASME CL 900	NA	89 (3.5)	75 (2.95)	92 (3.62)	127 (5)	190.5 (7.5)	241 (9.48)	26 (1.02)	38.1 (1.5)	9.5 (0.37)	8
3 in. ASME CL1500	NA	89 (3.5)	75 (2.95)	92 (3.62)	127 (5)	203.2 (8)	266.7 (10.5)	31.75 (1.25)	47.7 (1.88)	9.5 (0.37)	8
4 in. ASME CL 150	94 (3.7)	89 (3.5)	75 (2.95)	92 (3.62)	157.2 (6.2)	190.5 (7.5)	228.6 (9)	19.1 (0.79)	22.4 (0.88)	9.5 (0.37)	8
4 in. ASME CL 300	94 (3.7)	89 (3.5)	75 (2.95)	92 (3.62)	157.2 (6.2)	200.2 (7.88)	254 (10)	22 (0.86)	30.2 (1.19)	9.5 (0.37)	8

Dimensions mm. (in.) for S26RE											
Size/Rating	A (dia)				B (dia)	C (dia)	D (dia)	E (dia)	F (Note 2)	G	N° of holes
	extended diaphragm	flush diaphragm		flushing ring internal dia							
		std.	low thick.								
DN 50 EN PN 16	48 (1.9)	60 (2.36)	58 (2.28)	62 (2.44)	102 (4.02)	125 (4.92)	165 (6.5)	18 (0.71)	15 (0.58)	9.5 (0.37)	4
DN 50 EN PN 40	48 (1.9)	60 (2.36)	58 (2.28)	62 (2.44)	102 (4.02)	125 (4.92)	165 (6.5)	18 (0.71)	18 (0.67)	9.5 (0.37)	4
DN 50 EN PN 63	NA	60 (2.36)	58 (2.28)	62 (2.44)	102 (4.02)	135 (5.31)	180 (7.08)	22 (0.86)	23 (0.9)	9.5 (0.37)	4
DN 50 EN PN 100	NA	60 (2.36)	58 (2.28)	62 (2.44)	102 (4.02)	145 (5.71)	195 (7.67)	26 (1.02)	27 (1.06)	9.5 (0.37)	4
DN 80 EN PN 16	72 (2.83)	89 (3.5)	75 (2.95)	92 (3.62)	138 (5.43)	160 (6.3)	200 (7.87)	18 (0.71)	17 (0.67)	9.5 (0.37)	8
DN 80 EN PN 40	72 (2.83)	89 (3.5)	75 (2.95)	92 (3.62)	138 (5.43)	160 (6.3)	200 (7.87)	18 (0.71)	21 (0.83)	9.5 (0.37)	8
DN 80 EN PN 63	NA	89 (3.5)	75 (2.95)	92 (3.62)	138 (5.43)	170 (6.7)	215 (8.46)	22 (0.86)	25 (0.98)	9.5 (0.37)	8
DN 80 EN PN 100	NA	89 (3.5)	75 (2.95)	92 (3.62)	138 (5.43)	180 (7.08)	230 (9.05)	26 (1.02)	33 (1.3)	9.5 (0.37)	8
DN 100 EN PN 16	94 (3.7)	89 (3.5)	75 (2.95)	92 (3.62)	158 (6.22)	180 (7.08)	220 (8.66)	18 (0.71)	17 (0.67)	9.5 (0.37)	8
DN 100 EN PN 40	94 (3.7)	89 (3.5)	75 (2.95)	92 (3.62)	162 (6.38)	190 (7.48)	235 (9.25)	22 (0.86)	21 (0.83)	9.5 (0.37)	8

Dimensions mm. (in.) for S26RJ								
Size/Rating	A (dia) flush diaphragm	B (dia)	C (dia)	D (dia)	E (dia)	F (Note 3)	G	N° of holes
A50 Class 10K	60 (2.36)	96 (3.78)	120 (4.72)	155 (6.1)	19 (0.75)	16 (0.63)	9.5 (0.37)	4
A50 Class 20K	60 (2.36)	96 (3.78)	120 (4.72)	155 (6.1)	19 (0.75)	18 (0.71)	9.5 (0.37)	8
A50 Class 40K	60 (2.36)	104.3 (4.11)	130 (5.12)	165 (6.5)	19 (0.75)	26 (1.02)	9.5 (0.37)	8
A80 Class 10K	89 (3.5)	126 (4.96)	150 (5.91)	185 (7.28)	19 (0.75)	18 (0.71)	9.5 (0.37)	8
A80 Class 20K	89 (3.5)	132 (5.2)	160 (6.3)	200 (7.87)	23 (0.91)	22 (0.87)	9.5 (0.37)	8
A80 Class 40K	89 (3.5)	139.4 (5.49)	170 (6.69)	210 (8.27)	23 (0.91)	32 (1.26)	9.5 (0.37)	8
A100 Class 10K	89 (3.5)	151 (5.94)	175 (6.89)	210 (8.27)	19 (0.75)	18 (0.71)	9.5 (0.37)	8
A100 Class 20K	89 (3.5)	160 (6.3)	185 (7.28)	225 (8.86)	23 (0.91)	24 (0.94)	9.5 (0.37)	8

Note 1 - Flange thickness tolerance is +3.0 / -0.0 mm. (+0.12 / 0.0 in.).

Note 2 - Flange thickness tolerance is +1.0 / -1.3 mm. (+0.04 / 0.05 in.) up to 18 mm. or ±1.5 mm. (±0.06 in.) from 18 to 50 mm.

Note 3 - Flange thickness tolerance is +1.5 / -0.0 mm. (+0.06 / 0.0 in.) up to Class 20K or +2.0 / -0.0 mm. (+0.08 / 0.0 in.) from Class 20K to Class 50K.

...Dimensions

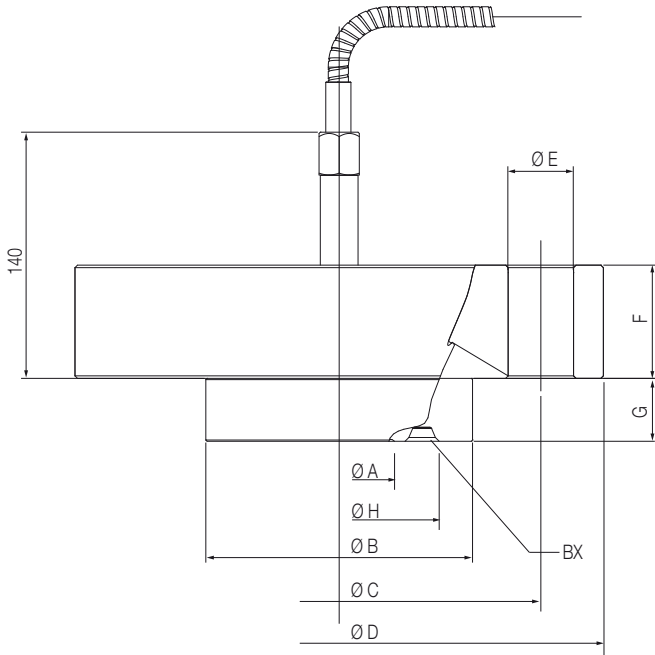

Figure 12 S26RH Rotating flange diaphragm seals according to ISO 10423 based on API 6A specification)

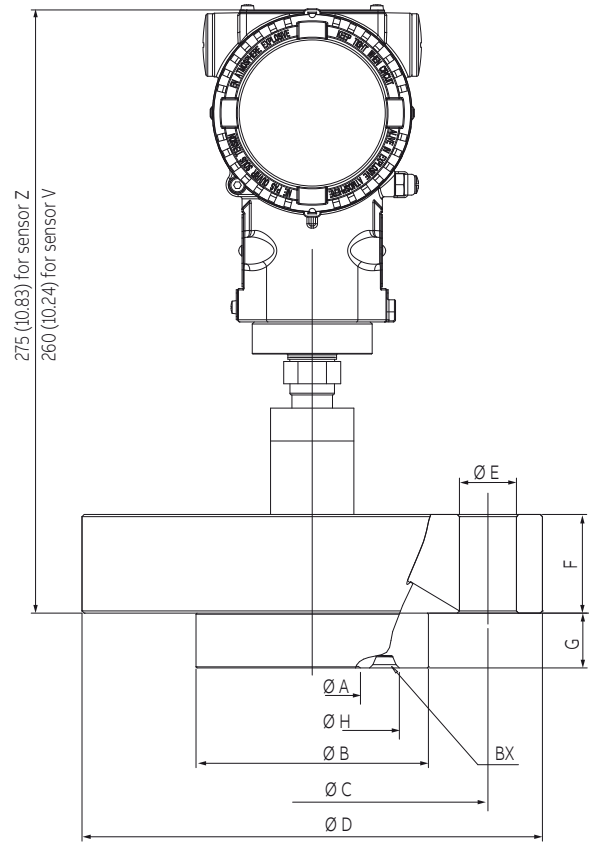

Figure 13 266HRH with barrel housing and direct mount seal S26RH flanged diaphragm seals (flush) to ISO 10423

Size/Rating	Dimensions mm. (in.) for S26RH									
	A (dia)	B (dia)	C (dia)	D (dia)	E (dia)	F	G	H (dia)	BX	N° of holes
1 13/16 in. API 10000	40 (1.57)	105.5 (4.15)	146.1 (5.75)	185 (7.28)	23 (0.91)	42.1 (1.66)	25 (0.98)	77.77 (3.06)	BX 151	8
1 13/16 in. API 15000	40 (1.57)	105.5 (4.15)	160.3 (6.31)	210 (8.27)	26 (1.02)	45 (1.77)	25 (0.98)	77.77 (3.06)	BX 151	8
2 1/16 in. API 10000	50 (1.97)	112.5 (4.43)	158.8 (6.25)	200 (7.87)	23 (0.91)	44.1 (1.74)	25 (0.98)	86.23 (3.40)	BX 152	8
2 1/16 in. API 15000	50 (1.97)	112.5 (4.43)	174.6 (6.87)	220 (8.66)	26 (1.02)	50.8 (2.00)	25 (0.98)	86.23 (3.40)	BX 152	8

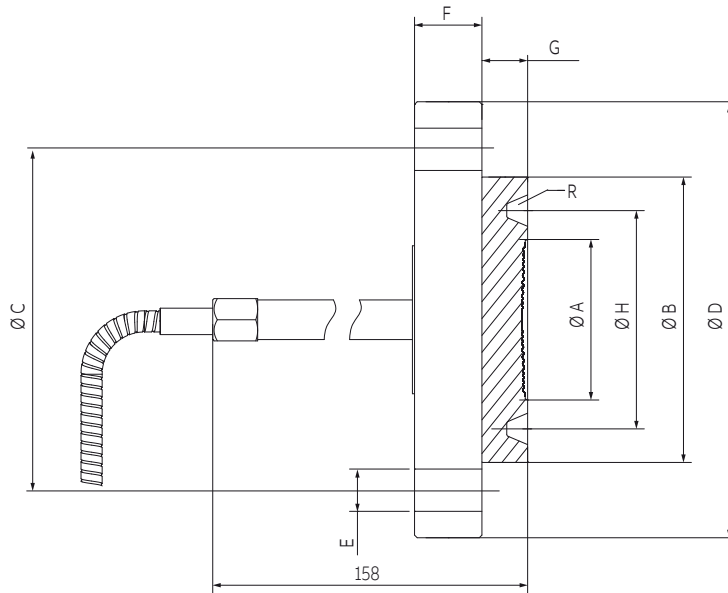

Figure 14 S26RR Rotating flange diaphragm seals - Ring Joint (RJ)

Size/Rating	Dimensions mm. (in.) for S26RR									N° of holes
	A (dia)	B (dia)	C (dia)	D (dia)	E (dia)	F	G	H (dia)	R	
1-1/2 in. ASME CL 150	48 (1.89)	83 (3.27)	98.6 (3.88)	127 (5)	15.75 (0.62)	17.5 (0.69)	17.3 (0.68)	65.1 (2.56)	R19	4
1-1/2 in. ASME CL 300	48 (1.89)	90 (3.54)	114.3 (4.5)	155.5 (6.12)	22.35 (0.88)	20.6 (0.81)	17.3 (0.68)	68.3 (2.69)	R20	4
1-1/2 in. ASME CL 600	48 (1.89)	90 (3.54)	114.3 (4.5)	155.5 (6.12)	22.35 (0.88)	22.4 (0.88)	17.3 (0.68)	68.3 (2.69)	R20	4
1-1/2 in. ASME CL 900/1500	48 (1.89)	92 (3.62)	124 (4.88)	177.8 (7)	28.45 (1.12)	31.8 (1.25)	20.8 (0.82)	68.3 (2.69)	R20	4
1-1/2 in. ASME CL 2500	48 (1.89)	114 (4.49)	146.1 (5.75)	203.2 (8)	31.75 (1.25)	44.5 (1.75)	20.8 (0.82)	82.6 (3.25)	R23	4
2 in. ASME CL 150	60 (2.36)	102 (4.02)	120.65 (4.75)	152.4 (6)	19.05 (0.75)	19.05 (0.75)	17.3 (0.68)	82.6 (3.25)	R22	4
2 in. ASME CL 300	60 (2.36)	108 (4.25)	127 (5)	165.1 (6.5)	19.05 (0.75)	22.35 (0.88)	17.3 (0.68)	82.6 (3.25)	R23	8
2 in. ASME CL 600	60 (2.36)	108 (4.25)	127 (5)	165.1 (6.5)	19.05 (0.75)	25.4 (1)	17.3 (0.68)	82.6 (3.25)	R23	8
2 in. ASME CL 900/1500	60 (2.36)	124 (4.88)	165 (6.5)	215.9 (8.5)	25.4 (1)	38.1 (1.5)	20.8 (0.82)	95.3 (3.75)	R24	8
2 in. ASME CL 2500	60 (2.36)	133 (5.24)	171.5 (6.75)	235 (9.25)	28.45 (1.12)	50.8 (2)	20.8 (0.82)	101.6 (4)	R26	8
3 in. ASME CL 150	89 (3.5)	133 (5.24)	152.4 (6)	190.5 (7.5)	19.05 (0.75)	23.87 (0.94)	17.3 (0.68)	114.3 (4.5)	R29	4
3 in. ASME CL 300	89 (3.5)	146 (5.75)	168.15 (6.62)	209.55 (8.25)	22.35 (0.88)	28.44 (1.12)	17.3 (0.68)	123.8 (4.87)	R31	8
3 in. ASME CL 600	89 (3.5)	146 (5.75)	168.15 (6.62)	209.55 (8.25)	22.35 (0.88)	31.75 (1.25)	17.3 (0.68)	123.8 (4.87)	R31	8
3 in. ASME CL 900	89 (3.5)	155 (6.10)	190.5 (7.5)	241.3 (9.5)	25.4 (1)	38.1 (1.50)	20.8 (0.82)	123.8 (4.87)	R31	8
3 in. ASME CL 1500	89 (3.5)	168 (6.61)	203.2 (8)	266.7 (10.5)	31.75 (1.25)	47.8 (1.88)	20.8 (0.82)	136.5 (5.37)	R35	8
3 in. ASME CL 2500	89 (3.5)	168 (6.61)	228.6 (9)	304.8 (12)	35.05 (1.38)	66.5 (2.62)	20.8 (0.82)	127 (5)	R32	8

...Dimensions

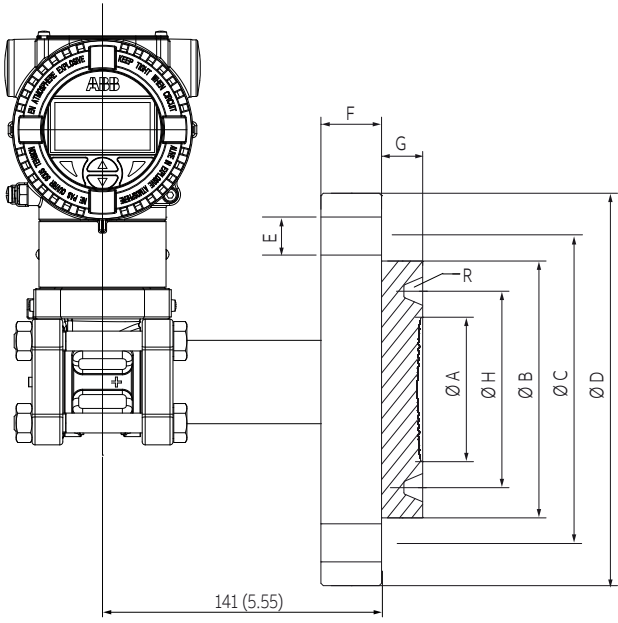

Figure 15 266DRH with barrel housing and direct mount seal S26RR flanged Ring Joint flush diaphragm

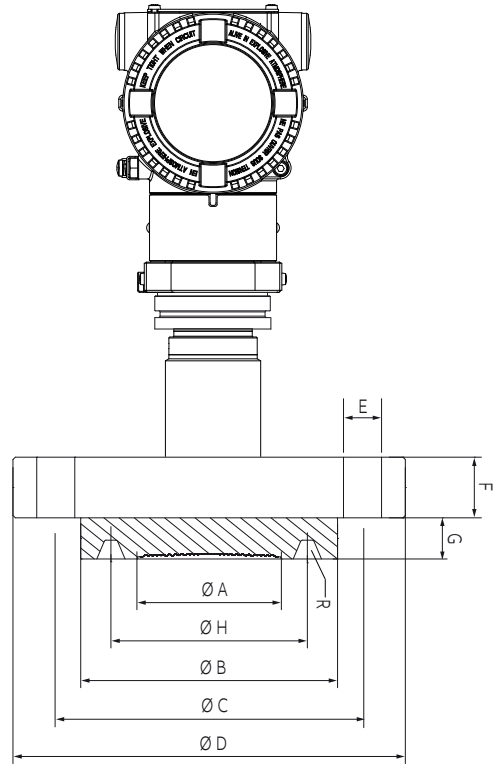

Figure 16 266HRH / 266NRH with barrel housing and direct mount seal S26RR flanged Ring Joint flush diaphragm

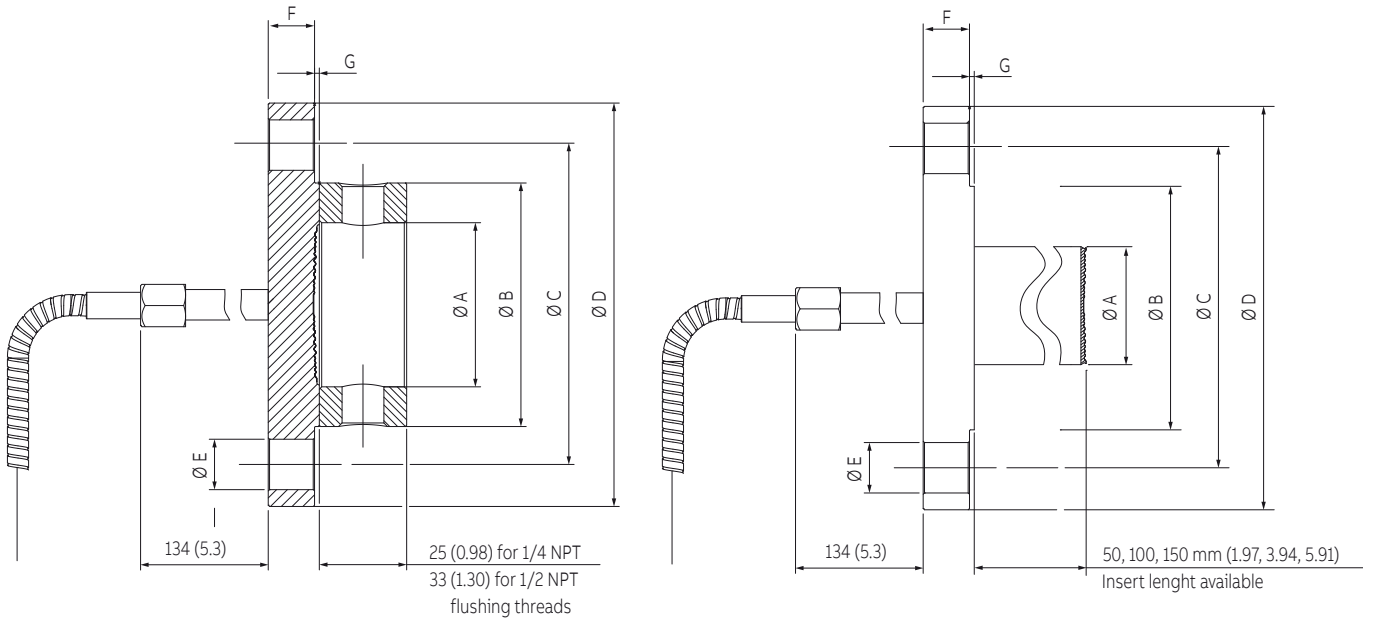

Figure 17 S26FA, S26FE Fixed flange diaphragm seals ASME and EN 1092-1 smooth and Form B1 (flushing ring as option, only for flush version)

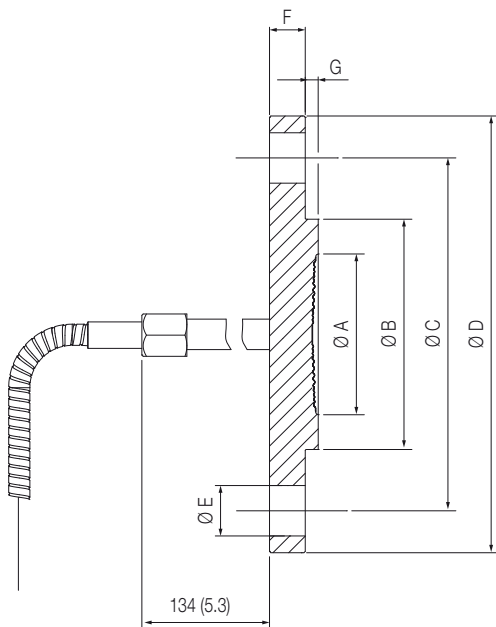

Figure 18 S26FA, S26FE Fixed flange diaphragm seals EN 1092-1 Form E

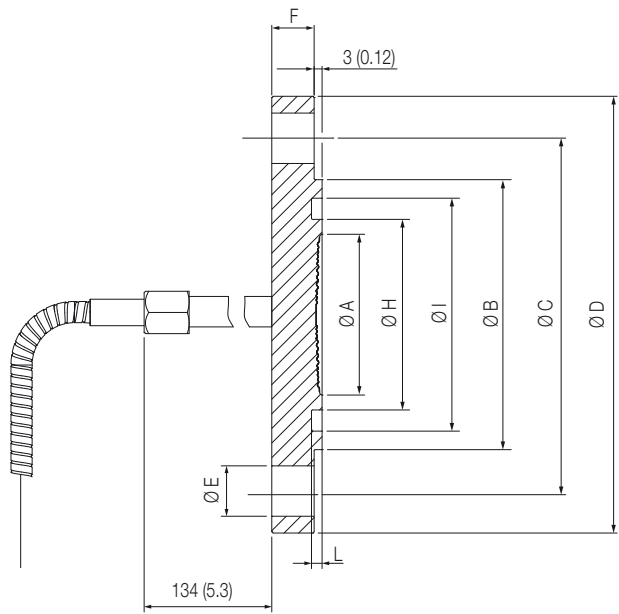

Figure 19 S26FA, S26FE Fixed flange diaphragm seals EN 1092-1 Form D

...Dimensions

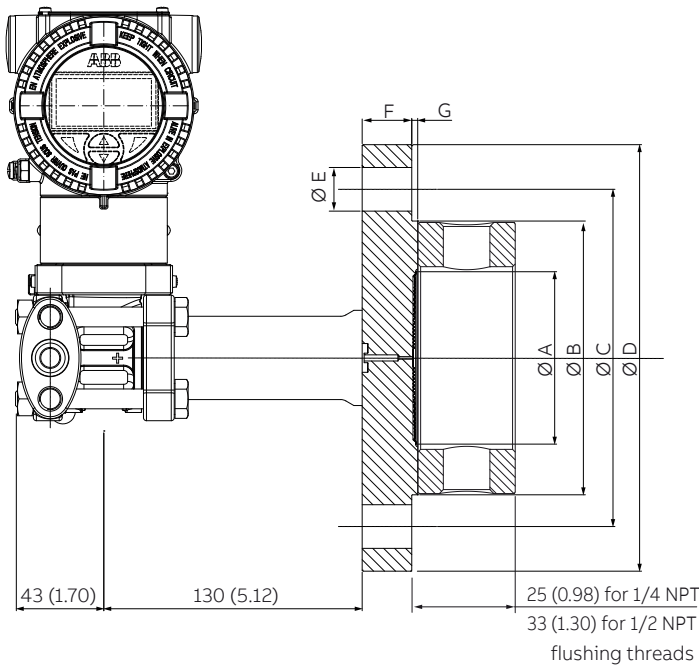

Figure 20 266DRH with barrel housing and direct mount seal S26FA/S26FE fixed flange Raised Face flush diaphragm ASME and EN 1092/1 smooth and Form B1 (flushing ring as option, only for flush version); Form E

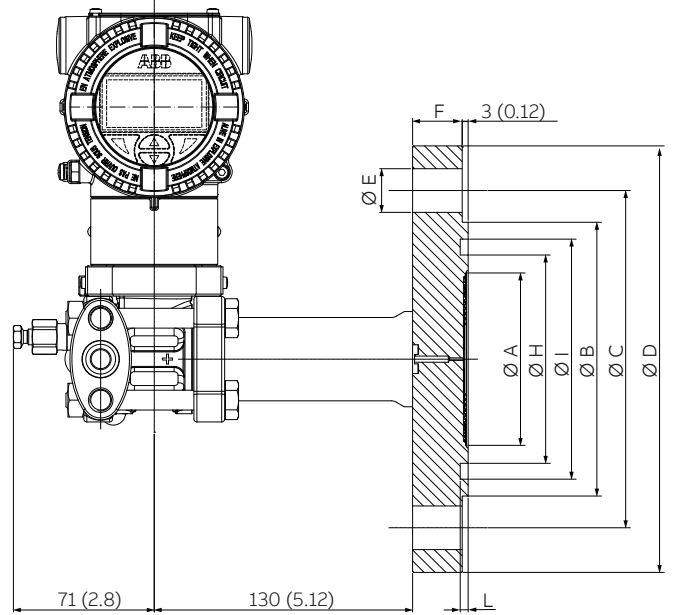

Figure 21 266DRH with barrel housing and direct mount seal S26FA/S26FE fixed flange Raised Face flush diaphragm EN 1092/1 Form D

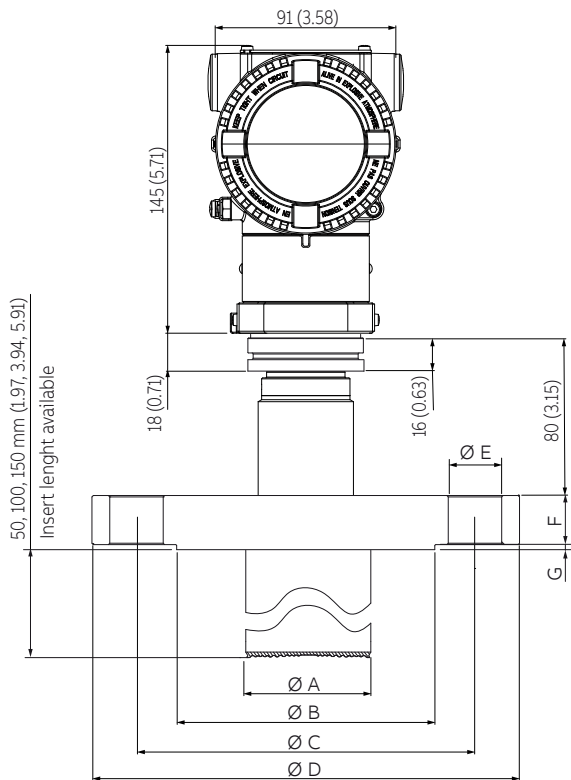

Figure 22 266HRH/266NRH with barrel housing and direct mount seal S26FA/S26FE fixed flange Raised Face ASME and EN 1092/1 smooth and Form B1; Form E (extension not available).

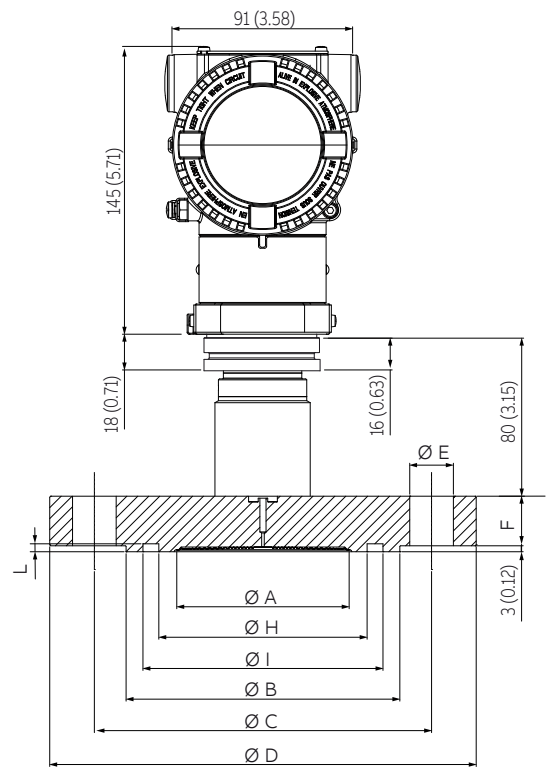

Figure 23 266HRH/266NRH with barrel housing and direct mount seal S26FA/S26FE fixed flange Raised Face EN 1092/1 Form D

Dimensions mm. (in.) for S26FA											
Size/Rating	A (dia)										N° of holes
	extended diaphragm	flush diaphragm		flushing ring internal dia	B (dia)	C (dia)	D (dia)	E (dia)	F (Note 1)	G	
		std.	low thick.								
2 in. ASME CL 150	48 (1.9)	60 (2.36)	58 (2.28)	62 (2.44)	92 (3.62)	120.65 (4.75)	152.4 (6)	19.1 (0.79)	17.5 (0.6)	2 (0.08)	4
2 in. ASME CL 300	48 (1.9)	60 (2.36)	58 (2.28)	62 (2.44)	92 (3.62)	127 (5)	165.1 (6.5)	19.1 (0.79)	20.8 (0.8)	2 (0.08)	8
2 in. ASME CL 600	48 (1.9)	60 (2.36)	58 (2.28)	62 (2.44)	92 (3.62)	127 (5)	165.1 (6.5)	19.1 (0.79)	25.4 (1)	7 (0.27)	8
3 in. ASME CL 150	72 (2.83)	89 (3.5)	75 (2.95)	92 (3.62)	127 (5)	152.4 (6)	190.5 (7.5)	19.1 (0.79)	22.4 (0.88)	2 (0.08)	4
3 in. ASME CL 300	72 (2.83)	89 (3.5)	75 (2.95)	92 (3.62)	127 (5)	168.15 (6.62)	209.6 (8.25)	22.4 (0.86)	26.9 (1.1)	2 (0.08)	8
3 in. ASME CL 600	72 (2.83)	89 (3.5)	75 (2.95)	92 (3.62)	127 (5)	168.15 (6.62)	209.6 (8.25)	22.4 (0.86)	31.8 (1.3)	7 (0.27)	8
4 in. ASME CL 150	94 (3.7)	89 (3.5)	75 (2.95)	92 (3.62)	157.2 (6.2)	190.5 (7.5)	228.6 (9)	19.1 (0.79)	22.4 (0.88)	2 (0.08)	8

Dimensions mm. (in.) for S26FE smooth and Form B1											
Size/Rating	A (dia)										N° of holes
	extended diaphragm	flush diaphragm		flushing ring internal dia	B (dia)	C (dia)	D (dia)	E (dia)	F (Note 2)	G	
		std.	low thick.								
DN 50 EN PN 16	48 (1.9)	60 (2.36)	58 (2.28)	62 (2.44)	102 (4.02)	125 (4.92)	165 (6.5)	18 (0.71)	15 (0.58)	3 (0.12)	4
DN 50 EN PN 40	48 (1.9)	60 (2.36)	58 (2.28)	62 (2.44)	102 (4.02)	125 (4.92)	165 (6.5)	18 (0.71)	18 (0.67)	3 (0.12)	4
DN 50 EN PN 63	NA	60 (2.36)	58 (2.28)	62 (2.44)	102 (4.02)	135 (5.31)	180 (7.08)	22 (0.86)	23 (0.9)	3 (0.12)	4
DN 50 EN PN 100	NA	60 (2.36)	58 (2.28)	62 (2.44)	102 (4.02)	145 (5.71)	195 (7.67)	26 (1.02)	27 (1.06)	3 (0.12)	4
DN 80 EN PN 16	72 (2.83)	89 (3.5)	75 (2.95)	92 (3.62)	138 (5.43)	160 (6.3)	200 (7.87)	18 (0.71)	17 (0.67)	3 (0.12)	8
DN 80 EN PN 40	72 (2.83)	89 (3.5)	75 (2.95)	92 (3.62)	138 (5.43)	160 (6.3)	200 (7.87)	18 (0.71)	21 (0.83)	3 (0.12)	8
DN 80 EN PN 63	NA	89 (3.5)	75 (2.95)	92 (3.62)	138 (5.43)	170 (6.7)	215 (8.46)	22 (0.86)	25 (0.98)	3 (0.12)	8
DN 80 EN PN 100	NA	89 (3.5)	75 (2.95)	92 (3.62)	138 (5.43)	180 (7.08)	230 (9.05)	26 (1.02)	33 (1.3)	3 (0.12)	8
DN 100 EN PN 16	94 (3.7)	89 (3.5)	75 (2.95)	92 (3.62)	158 (6.22)	180 (7.08)	220 (8.66)	18 (0.71)	17 (0.67)	3 (0.12)	8

Dimensions mm. (in.) for S26FE Form E											
Size/Rating	diaphragm A (dia)		B (dia)	C (dia)	D (dia)	E (dia)	F (Note 2)	G	N° of holes		
	std. thickness	low thickness									
	DN 50 EN PN 16	60 (2.36)								58 (2.28)	87 (3.42)
DN 50 EN PN 40	60 (2.36)	58 (2.28)	87 (3.42)	125 (4.92)	165 (6.5)	18 (0.71)	15.5 (0.61)	4.5 (0.18)	4		
DN 50 EN PN 63	60 (2.36)	58 (2.28)	87 (3.42)	135 (5.31)	180 (7.08)	22 (0.86)	21.5 (0.85)	4.5 (0.18)	4		
DN 50 EN PN 100	60 (2.36)	58 (2.28)	87 (3.42)	145 (5.71)	195 (7.67)	26 (1.02)	25.5 (1)	4.5 (0.18)	4		
DN 80 EN PN 16	89 (3.5)	75 (2.95)	120 (4.72)	160 (6.3)	200 (7.87)	18 (0.71)	15.5 (0.61)	4.5 (0.18)	8		
DN 80 EN PN 40	89 (3.5)	75 (2.95)	120 (4.72)	160 (6.3)	200 (7.87)	18 (0.71)	19.5 (0.77)	4.5 (0.18)	8		
DN 80 EN PN 63	89 (3.5)	75 (2.95)	120 (4.72)	170 (6.7)	215 (8.46)	22 (0.86)	23.5 (0.92)	4.5 (0.18)	8		
DN 80 EN PN 100	89 (3.5)	75 (2.95)	120 (4.72)	180 (7.08)	230 (9.05)	26 (1.02)	31.5 (1.24)	4.5 (0.18)	8		

Dimensions mm. (in.) for S26FE Form D											
Size/Rating	diaphragm A (dia)		B (dia)	C (dia)	D (dia)	E (dia)	F (Note 2)	H (dia)	I (dia)	L	N° of holes
	std. thickness	low thickness									
	DN 50 EN PN 16	60 (2.36)									
DN 50 EN PN 40	60 (2.36)	58 (2.28)	102 (4.02)	125 (4.92)	165 (6.5)	18 (0.71)	18 (0.71)	72 (2.83)	88 (3.46)	4 (0.16)	4
DN 50 EN PN 63	60 (2.36)	58 (2.28)	102 (4.02)	135 (5.31)	180 (7.08)	22 (0.86)	23 (0.91)	72 (2.83)	88 (3.46)	4 (0.16)	4
DN 50 EN PN 100	60 (2.36)	58 (2.28)	102 (4.02)	145 (5.71)	195 (7.67)	26 (1.02)	27 (1.06)	72 (2.83)	88 (3.46)	4 (0.16)	4
DN 80 EN PN 16	89 (3.5)	75 (2.95)	138 (5.43)	160 (6.3)	200 (7.87)	18 (0.71)	17 (0.67)	105 (4.13)	121 (4.76)	4 (0.16)	8
DN 80 EN PN 40	89 (3.5)	75 (2.95)	138 (5.43)	160 (6.3)	200 (7.87)	18 (0.71)	21 (0.83)	105 (4.13)	121 (4.76)	4 (0.16)	8
DN 80 EN PN 63	89 (3.5)	75 (2.95)	138 (5.43)	170 (6.7)	215 (8.46)	22 (0.86)	25 (0.92)	105 (4.13)	121 (4.76)	4 (0.16)	8
DN 80 EN PN 100	89 (3.5)	75 (2.95)	138 (5.43)	180 (7.08)	230 (9.05)	26 (1.02)	33 (1.3)	105 (4.13)	121 (4.76)	4 (0.16)	8

Note 1 - Flange thickness tolerance is +3.0 / -0.0 mm. (+0.12 / 0.0 in.).

Note 2 - Flange thickness tolerance is +1.0 / -1.3 mm. (+0.04 / 0.05 in.) up to 18 mm. or ±1.5 mm. (±0.06 in.) from 18 to 50 mm.

...Dimensions

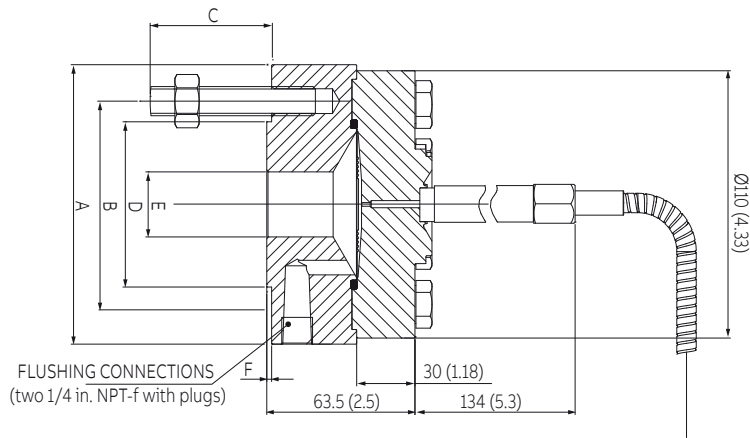

Figure 24 S26MA, S26ME Model off-line flanged diaphragm seal

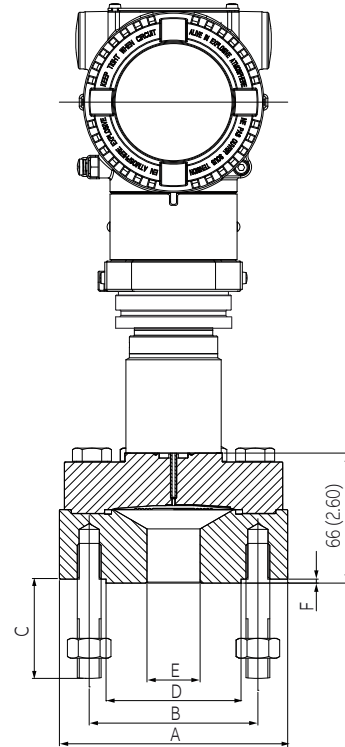

Figure 25 266HRH / 266NRH with barrel housing and direct mount seal S26Mx off-line flanged

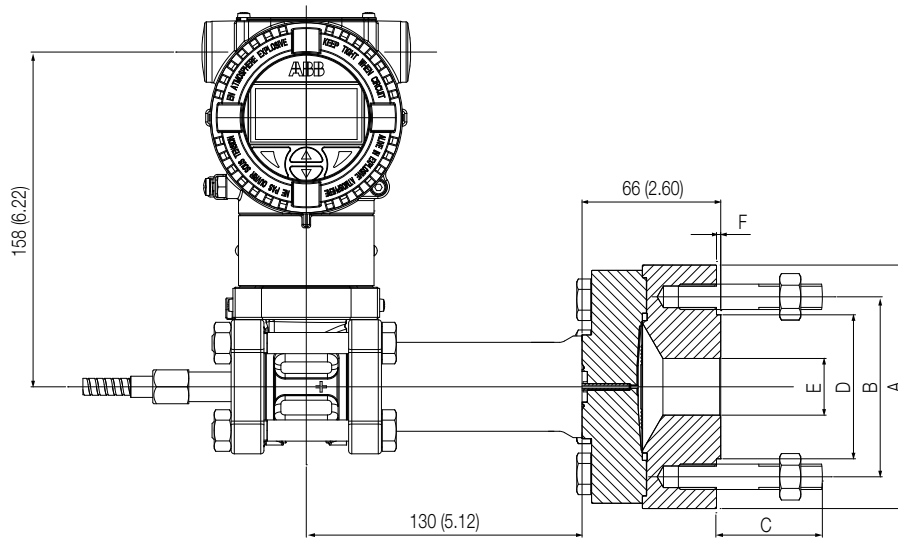
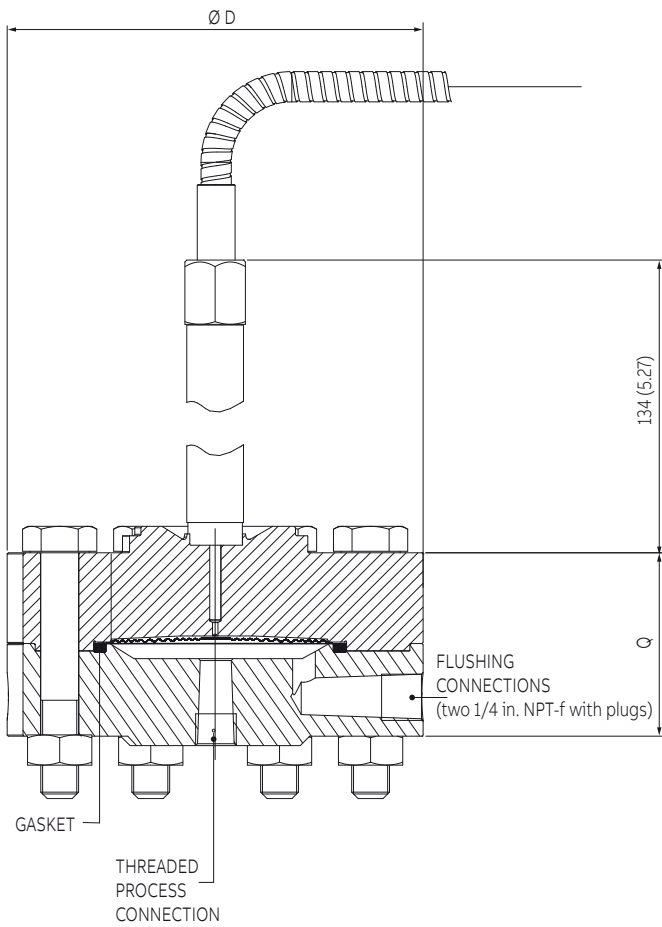

Figure 26 266DRH with barrel housing and direct mount seal S26Mx off-line flanged

Size/Rating	Dimensions mm. (in.) for S26MA and S26ME						
	A (dia)	B (dia)	C (4 studs)		D (dia)	E (dia)	F
			Length	Thread			
1/2 in. ASME CL 150	110 (4.33)	60.5 (2.38)	39 (1.53)	1/2 in. – 13 UNC	35.1 (1.38)	15.8 (0.62)	1.6 (0.06)
1/2 in. ASME CL 300	110 (4.33)	66.5 (2.62)	39 (1.53)	1/2 in. – 13 UNC	35.1 (1.38)	15.8 (0.62)	1.6 (0.06)
1 in. ASME CL 150	110 (4.33)	79.4 (3.12)	39 (1.53)	1/2 in. – 13 UNC	50.8 (2)	26.7 (1.05)	1.6 (0.06)
1 in. ASME CL 300	124 (4.88)	88.9 (3.5)	51 (2)	5/8 in. – 11 UNC	50.8 (2)	26.7 (1.05)	1.6 (0.06)
1 1/2 in. ASME CL 150	127 (5)	98.4 (3.87)	39 (1.53)	1/2 in. – 13 UNC	73 (2.87)	41 (1.61)	1.6 (0.06)
1 1/2 in. ASME CL 300	155 (6.1)	114.3 (4.5)	57 (2.24)	3/4 in. – 10 UNC	73 (2.87)	41 (1.61)	1.6 (0.06)
DN 25 PN 16-40	115 (4.52)	85 (3.34)	42 (1.65)	M12	68 (2.67)	28.5 (1.12)	2 (0.08)
DN 40 PN 16-40	150 (5.9)	110 (4.33)	48 (1.89)	M16	88 (3.46)	43.1 (1.69)	3 (0.12)



Size (thread)	Dimensions mm. (in.) for S26TT	
	D (dia)	Q
1/4 in. NPT	109.2 (4.3)	53.3 (2.1)
1/2 in. NPT	109.2 (4.3)	53.3 (2.1)
3/4 in. NPT	109.2 (4.3)	63.5 (2.5)
1 in. NPT	109.2 (4.3)	63.5 (2.5)
1 1/2 in. NPT	109.2 (4.3)	63.5 (2.5)

Figure 27 S26TT Model off-line threaded diaphragm seal

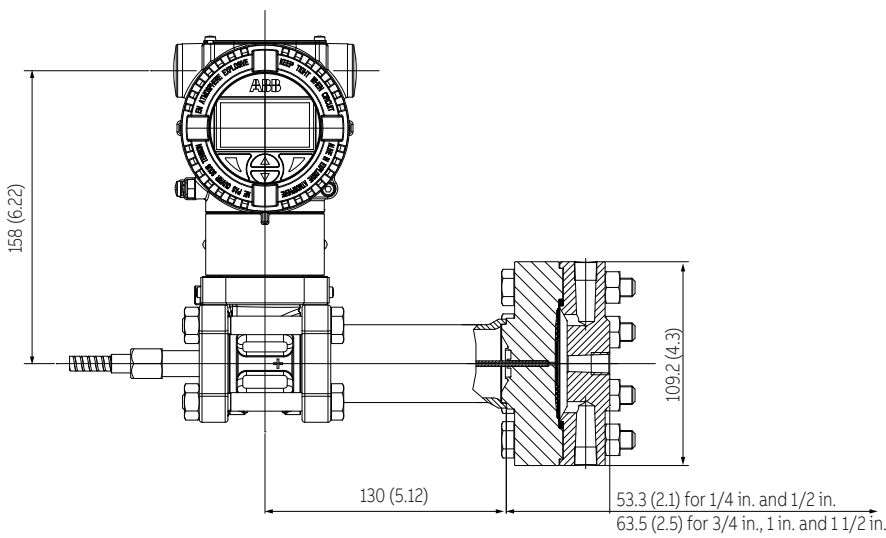

Figure 28 266DRH with barrel housing and direct mount seal S26TT off-line threaded flange

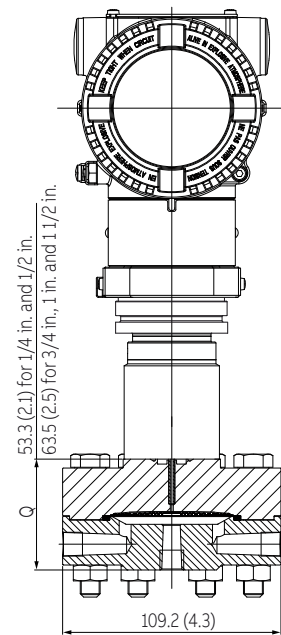
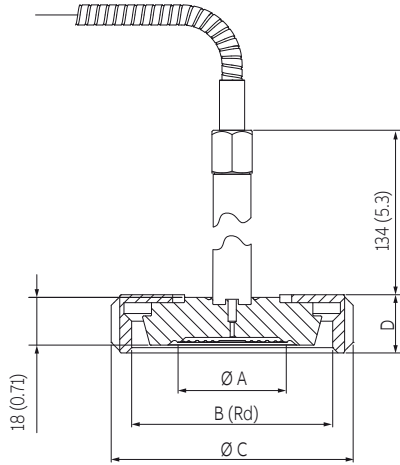

Figure 29 266HRH / 266NRH with barrel housing and direct mount seal S26TT off-line threaded flange

...Dimensions



Size	Dimensions mm. (in.) for S26SS Union Nut to DIN 11851			
	A (dia)	B (Rd)	C (dia)	D
F50	42 (1.65)	78 (3.07)	92 (3.62)	22 (0.87)
F80	72 (2.83)	110 (4.33)	127 (5)	29 (1.14)

Figure 30 S26SS Union Nut seal

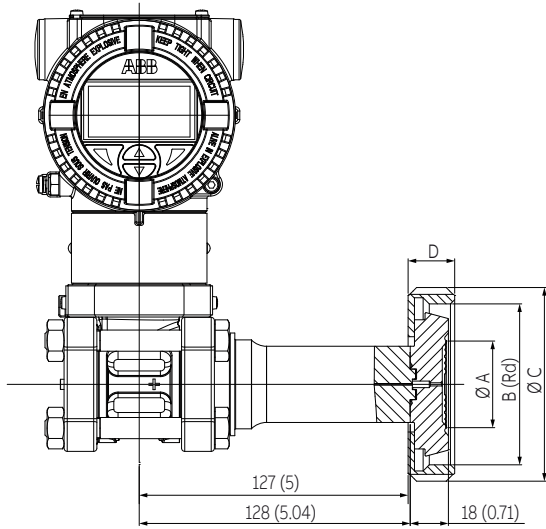

Figure 31 266DRH with barrel housing and direct mount seal S26SS Union Nut

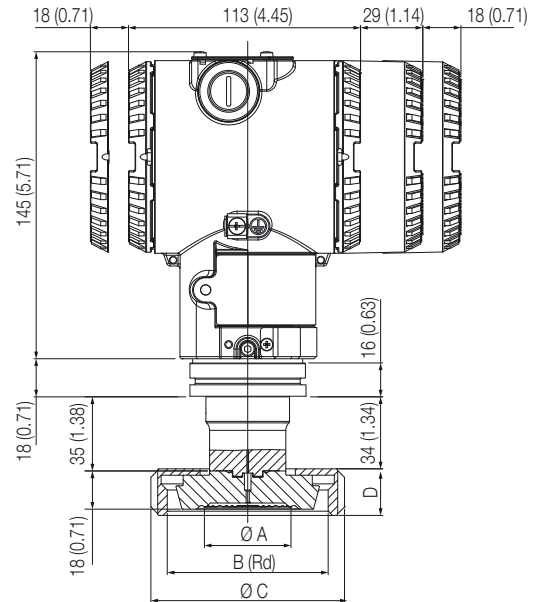
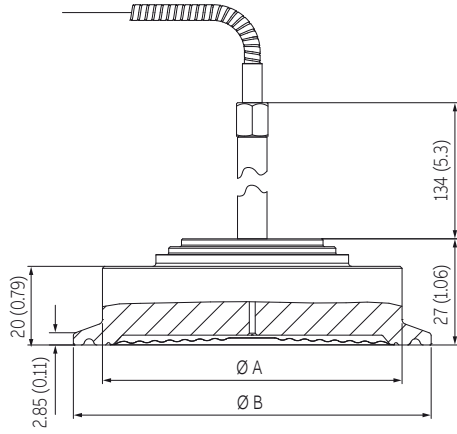

Figure 32 266HRH / 266NRH with barrel housing and direct mount seal S26SS Union Nut



Size	Dimensions mm. (in.) for S265S Triclamp	
	A (dia)	B (dia)
2 in.	56.3 (2.2)	64 (2.5)
3 in.	83 (3.26)	91 (3.58)
4 in.	110.3 (4.34)	119 (4.68)

Figure 33 S265S Triclamp seal

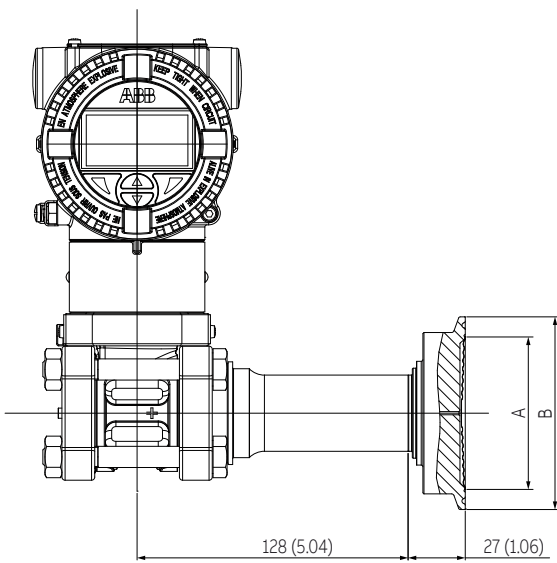

Figure 34 266DRH with barrel housing and direct mount seal S265S Triclamp

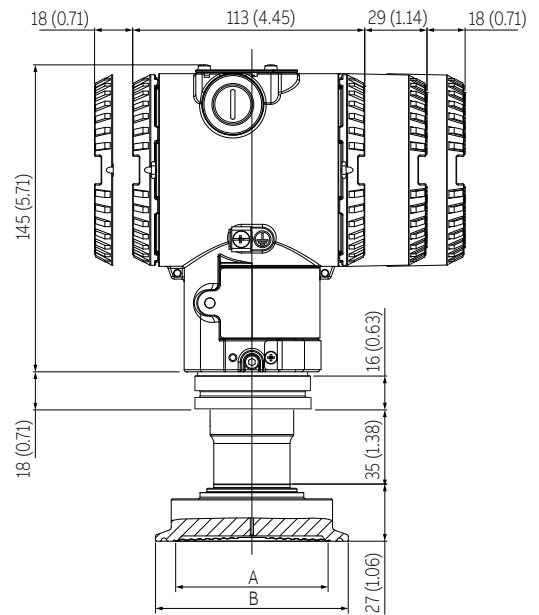

Figure 35 266HRH / 266NRH with barrel housing and direct mount seal S265S Triclamp

...Dimensions

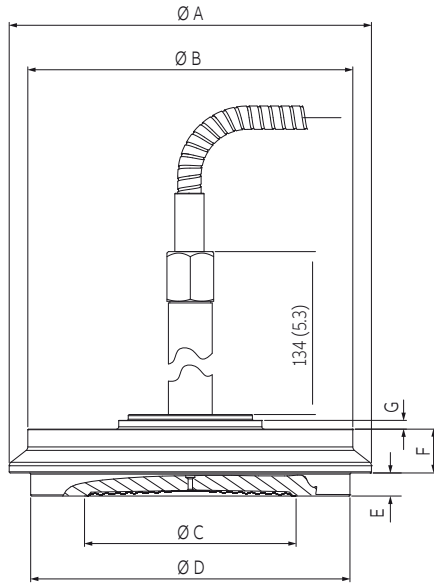

Figure 36 S26SS Cherry Burrell seal

Size	Dimensions mm. (in.) for S26SS Cherry Burrell						
	A (dia)	B (dia)	C (dia)	D (dia)	E	F	G
2 in.	67 (2.64)	56 (2.2)	47.7 (1.88)	57 (2.24)	6.5 (0.26)	12.5 (0.49)	3 (0.12)
3 in.	98.4 (3.87)	81 (3.19)	71 (2.80)	83.8 (3.3)	7.9 (0.31)	15 (0.59)	3 (0.12)
4 in.	124 (4.88)	111.25 (4.38)	71 (2.80)	109.3 (4.3)	7.9 (0.31)	15 (0.59)	3 (0.12)

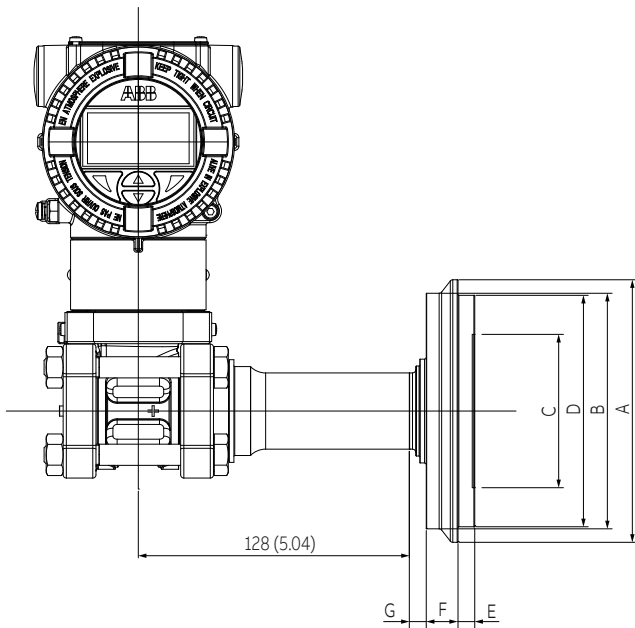

Figure 37 266DRH with barrel housing and direct mount seal S26SS Cherry Burrell

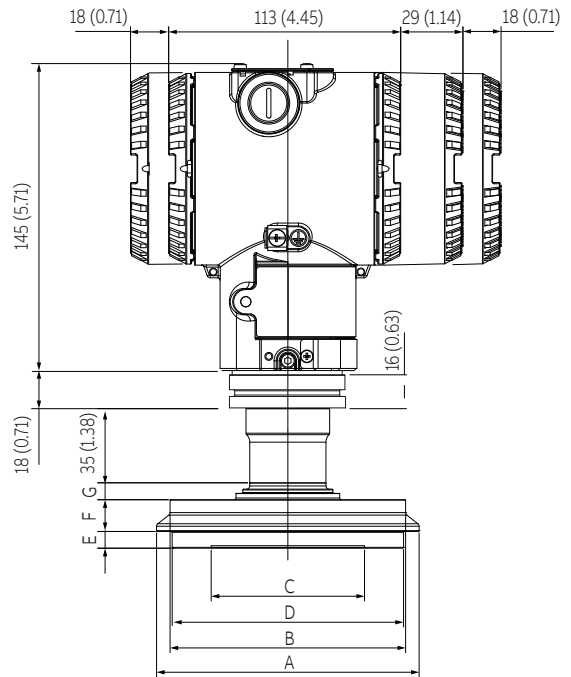

Figure 38 266HRH / 266NRH with barrel housing and direct mount seal S26SS Cherry Burrell

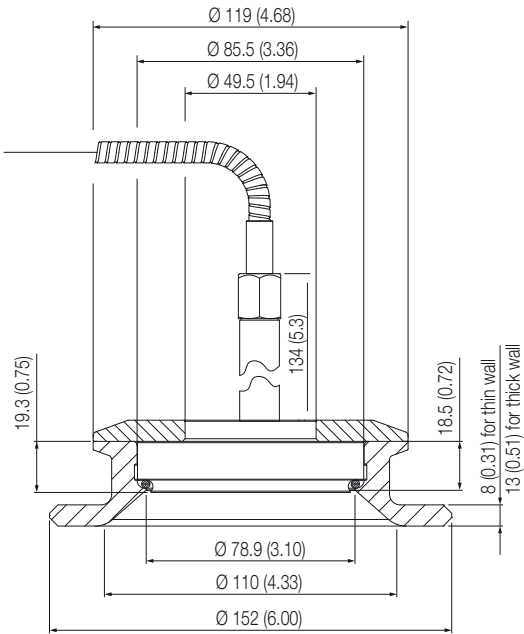

Figure 39 S26SS Sanitary flush seal

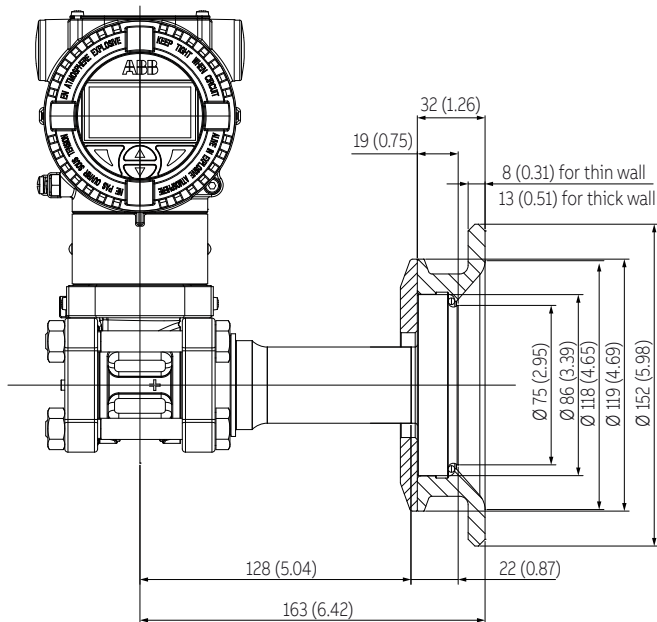

Figure 40 266DRH with barrel housing and direct mount seal S26SS Sanitary flush

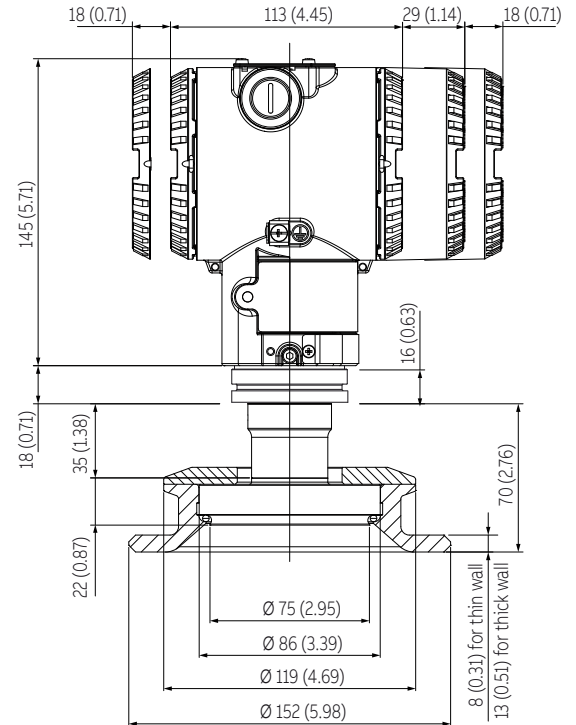

Figure 41 266HRH / 266NRH with barrel housing and direct mount seal S26SS Sanitary flush

...Dimensions

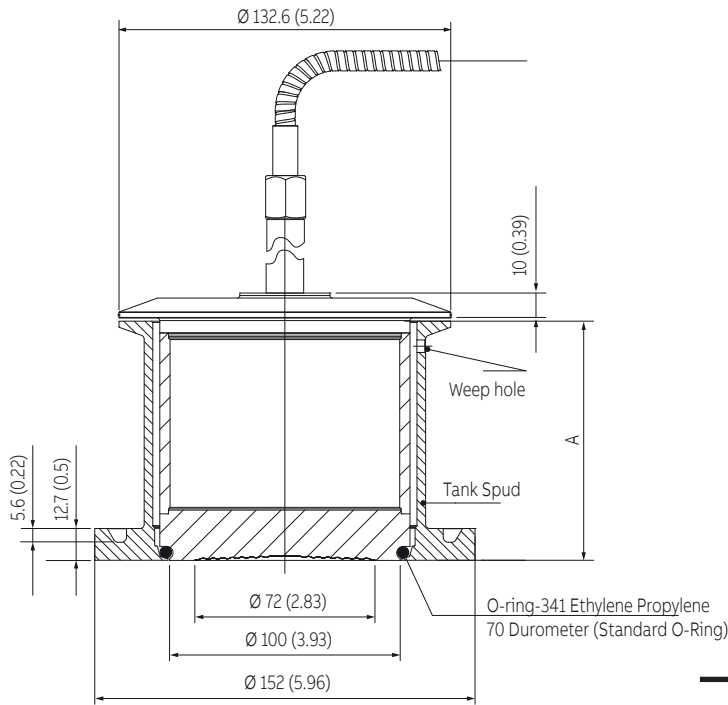

Figure 42 S26SS Sanitary extended seal

Size	Dimensions mm. (in.) for S26SS Sanitary extended	
	A	
2in	53.3 (2.1)	
4in	104.1 (4.1)	
6in	154.9 (6.1)	

NOTE

The tank spud required for connection of this seal element must be welded to the process vessel prior to connecting the seal, following a recommended welding and pressure testing procedure.

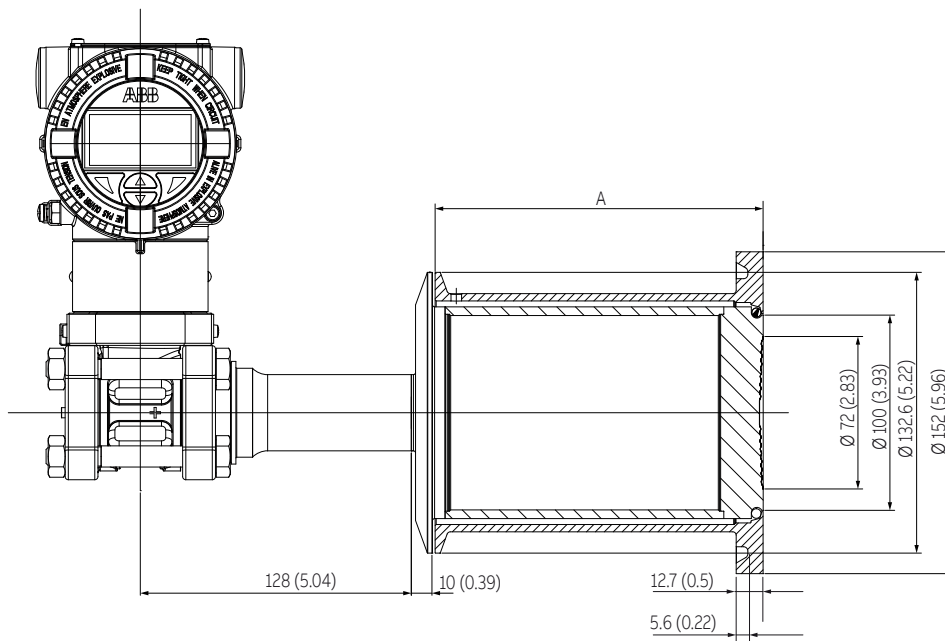
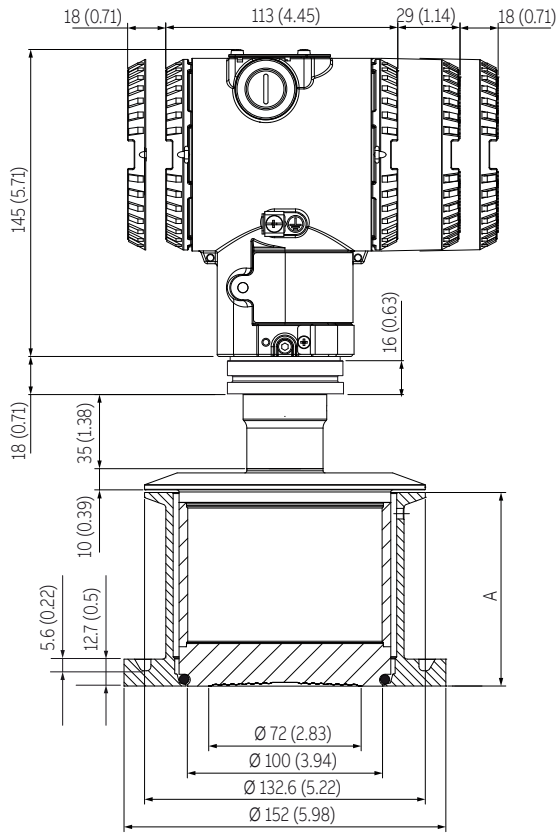

Figure 43 266DRH with barrel housing and direct mount seal S26SS Sanitary extended



Dimensions mm. (in.) for S26SS Sanitary extended	
Size	A
2in	53.3 (2.1)
4in	104.1 (4.1)
6in	154.9 (6.1)

Figure 44 266HRH / 266NRH with barrel housing and direct mount seal S26SS Sanitary extended

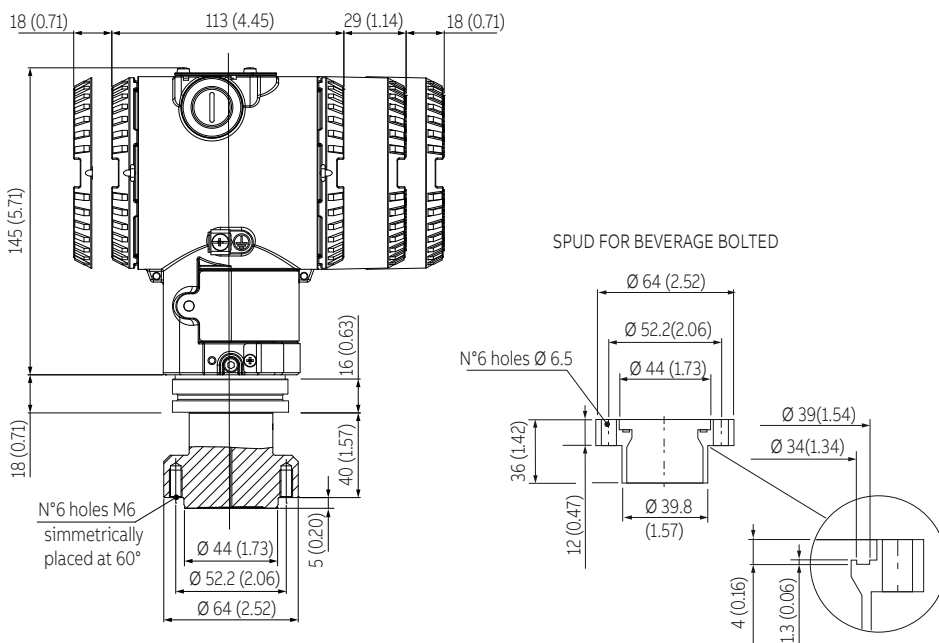

Figure 45 266HRH / 266NRH with barrel housing and direct mount seal S26SS beverage bolted

...Dimensions

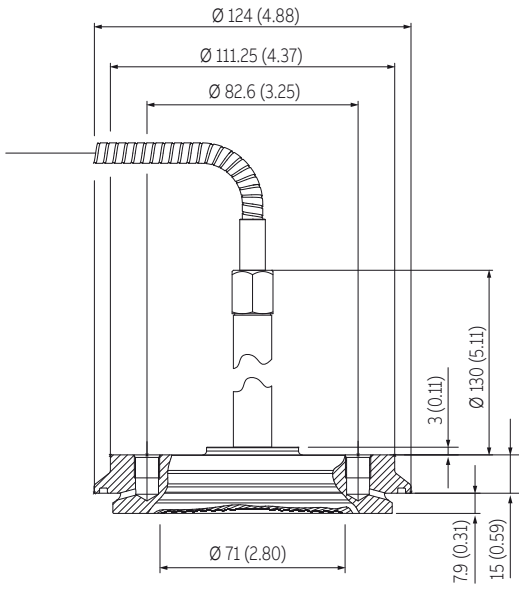

Figure 46 S26SS 4 in. Cherry Burrell Aseptic Sanitary seal

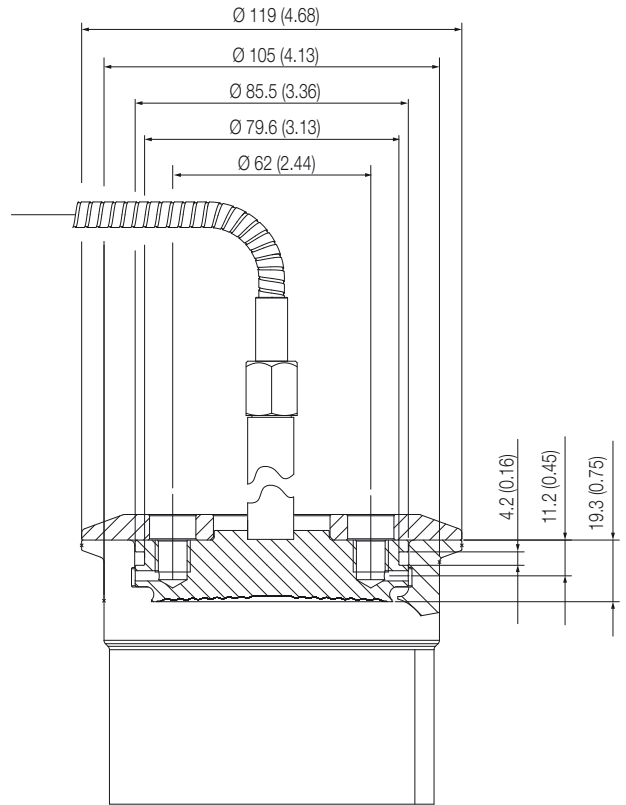

Figure 47 S26SS 4 in. Aseptic Flanged Connection Sanitary seal

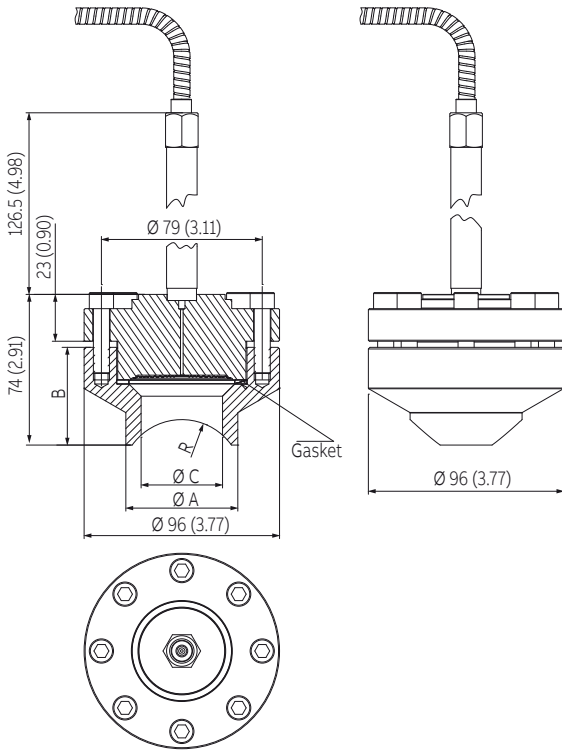

Figure 48 S26VN saddle seal

Fitting connection Size	Dimensions mm. (in.) for S26VN- saddle type			
	A (dia)	B	C (dia)	R
Saddle 2 in.	55 (2.17)	48 (1.89)	40 (1.57)	30
Saddle 2 1/2 in.	76 (3.0)	45 (1.77)	52 (2.05)	45
Saddle 3 in.	76 (3.0)	45 (1.77)	50 (1.97)	45
Saddle 4 in.	76 (3.0)	41 (1.61)	50 (1.97)	57
Saddle 5 in.	76 (3.0)	40 (1.57)	50 (1.97)	70
Saddle 6 in.	76 (3.0)	36 (1.42)	50 (1.97)	85

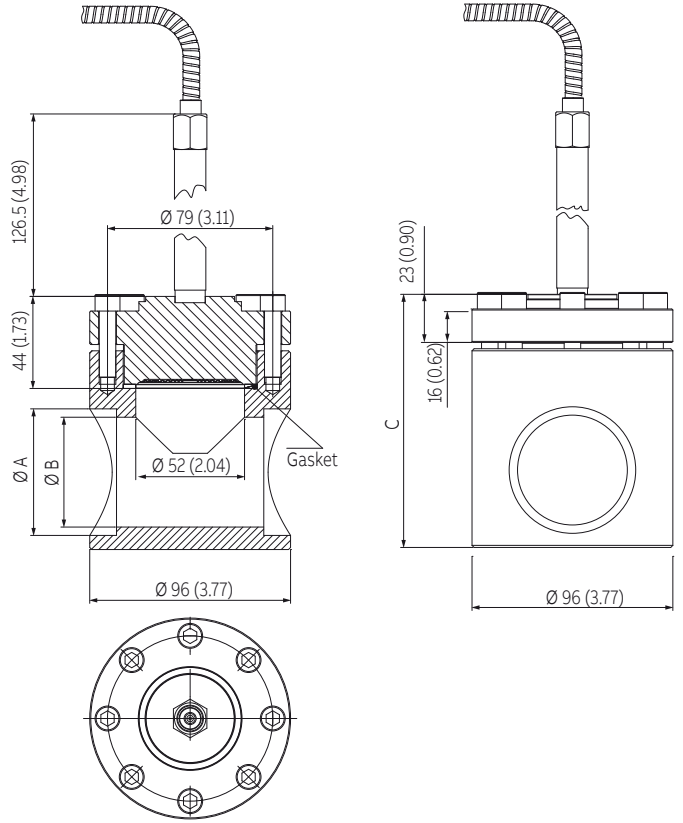

Figure 49 S26VN socket seal

Fitting connection Size	Dimensions mm. (in.) for S26VN- socket type		
	A (dia)	B	C
Socket 1/2 in.	21.8 (0.86)	15.9 (0.63)	86 (3.39)
Socket 3/4 in.	27 (1.06)	21.2 (0.83)	96 (3.78)
Socket 1 in.	33.6 (1.32)	26.8 (1.06)	101 (3.98)
Socket 1 1/2 in.	48.5 (1.91)	41 (1.61)	121 (4.76)
Socket 2 in.	60.5 (2.38)	52.5 (2.07)	121 (4.76)

...Dimensions

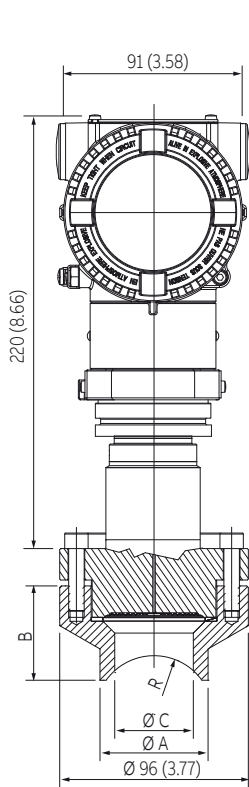

Figure 50 266HRH / 266NRH with barrel housing and direct mount seal S26VN saddle and socket

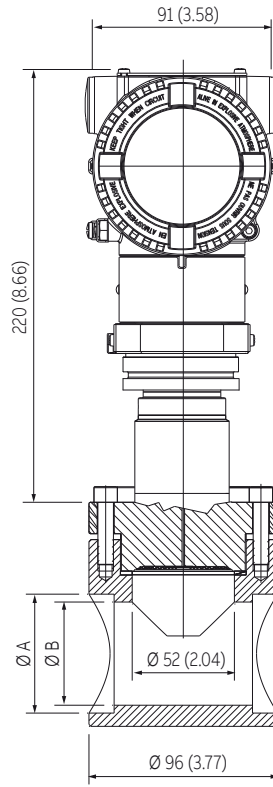

Figure 51 266HRH / 266NRH with barrel housing and direct mount seal S26VN saddle and socket

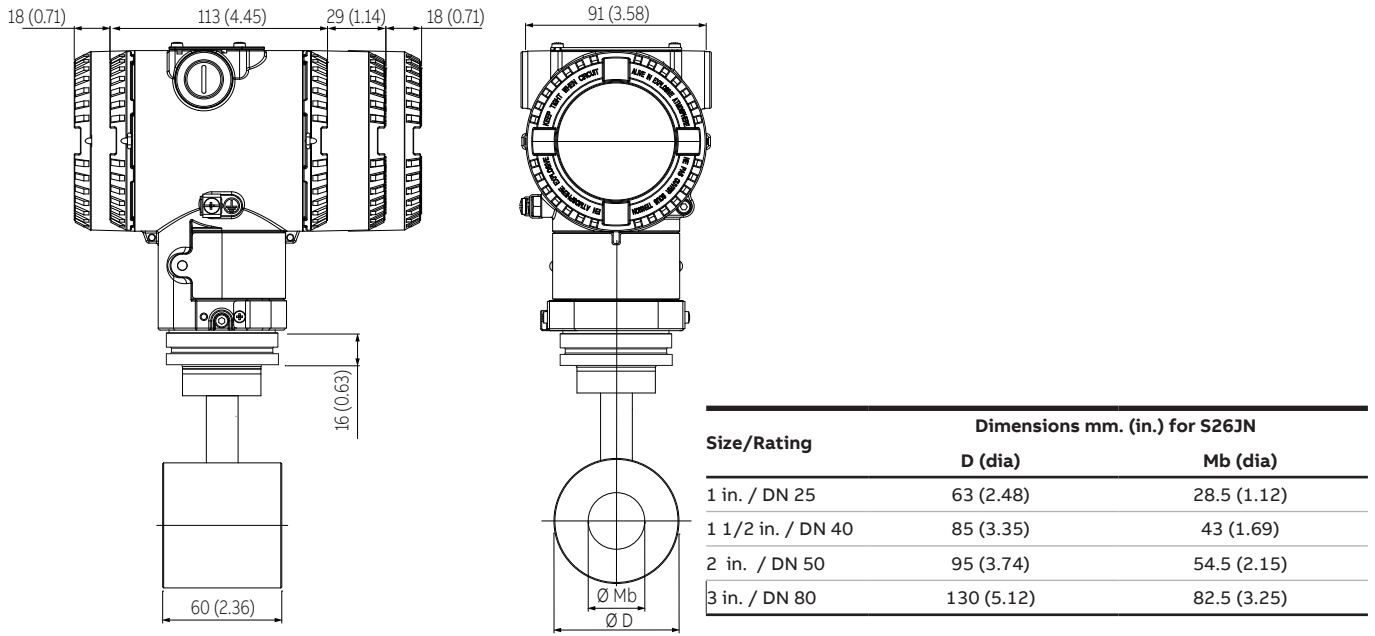

Figure 52 266HRH / 266NRH with barrel housing and direct mount seal S26JN in-line

...Dimensions

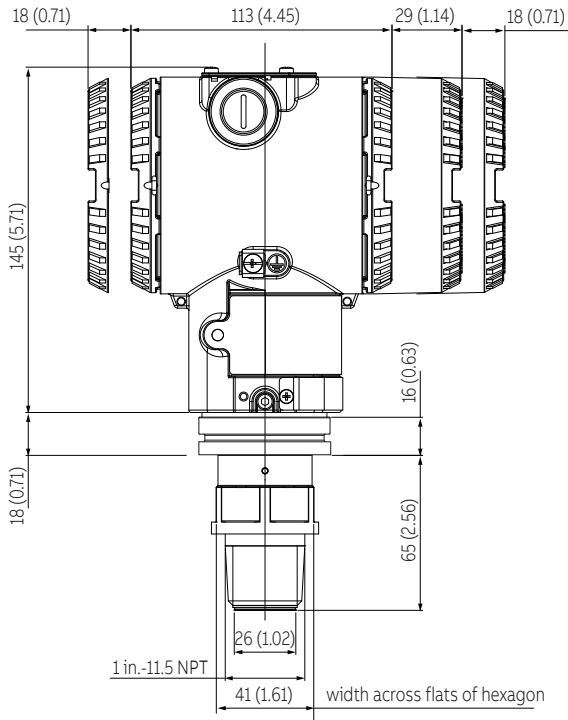

Figure 53 266HRH / 266NRH with barrel housing and direct mount seal S26KN pulp and paper 1 in. NPT threaded connections

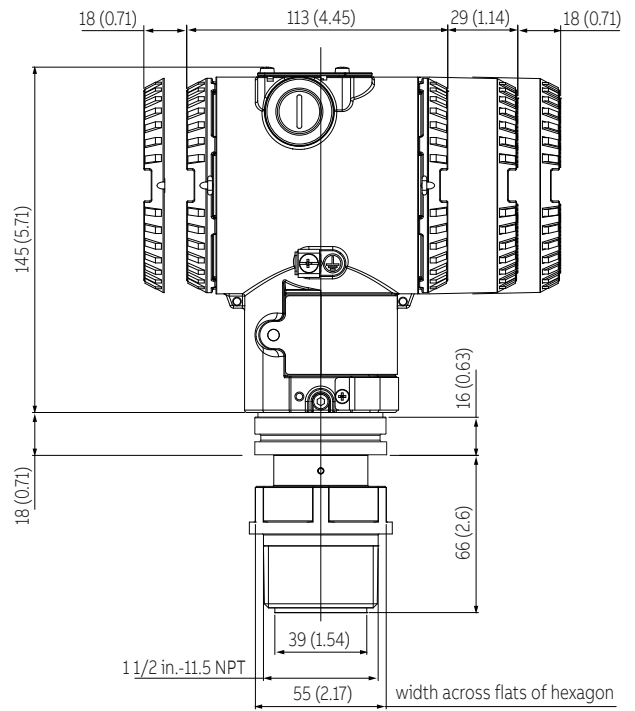

Figure 55 266HRH / 266NRH with barrel housing and direct mount seal S26KN pulp and paper 1 1/2 in. NPT threaded connections

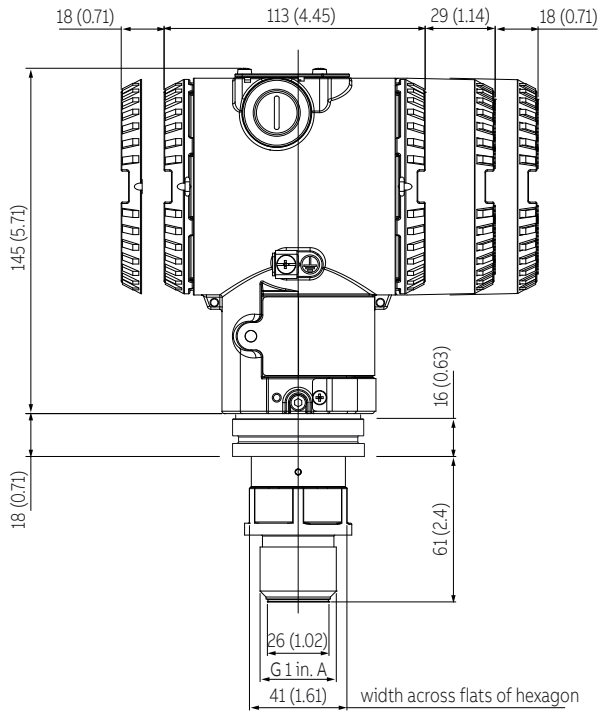

Figure 54 266HRH / 266NRH with barrel housing and direct mount seal S26KN pulp and paper 1 in. Gas threaded connections

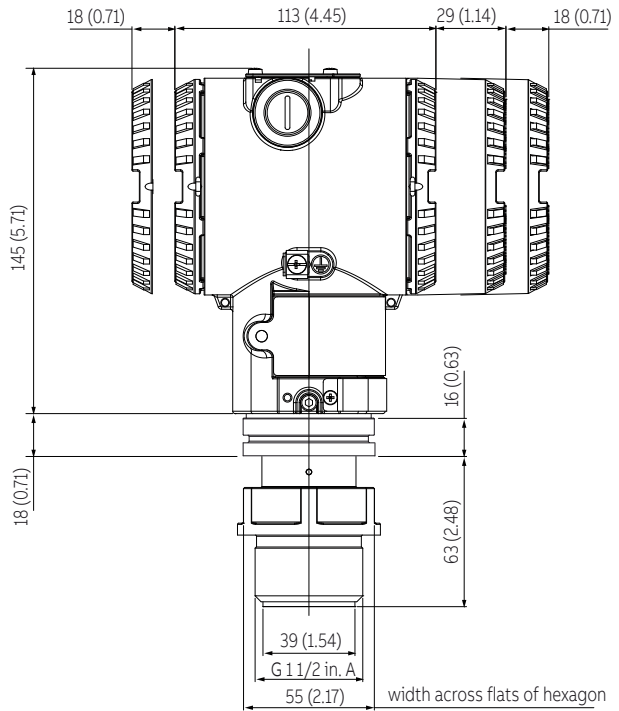

Figure 56 266HRH / 266NRH with barrel housing and direct mount seal S26KN pulp and paper 1 1/2 in. Gas threaded connections

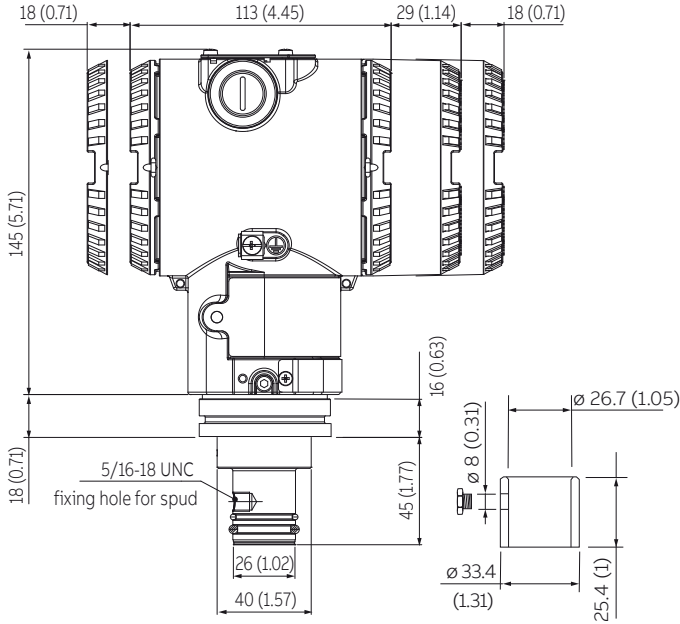

Figure 57 266HRH / 266NRH with barrel housing and direct mount seal S26KN pulp and paper 1 in. sealing with gasket

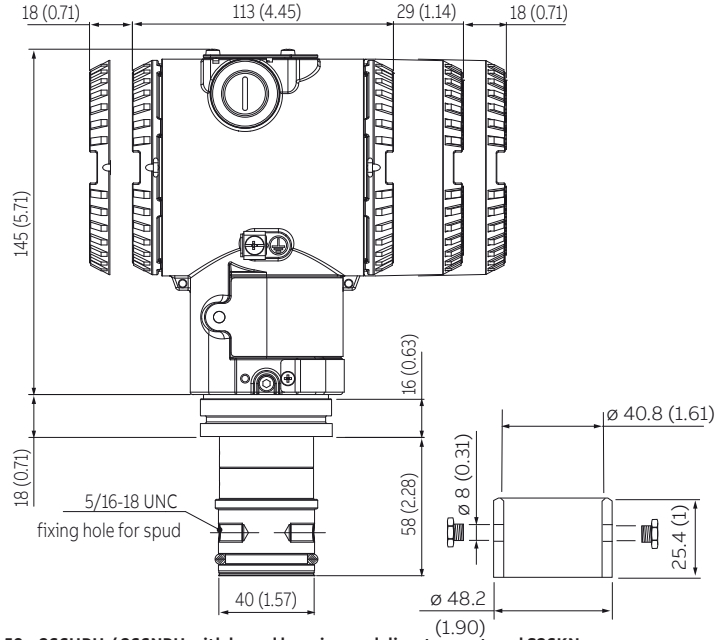

Figure 59 266HRH / 266NRH with barrel housing and direct mount seal S26KN pulp and paper 1 1/2 in. sealing with gasket

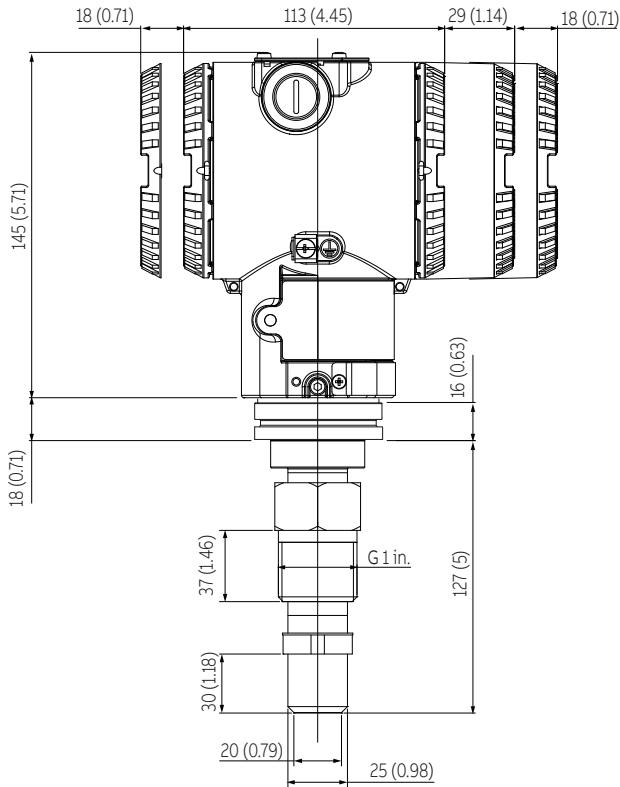

Figure 58 266HRH / 266NRH with barrel housing and direct mount seal S26KN pulp and paper ball valve connections

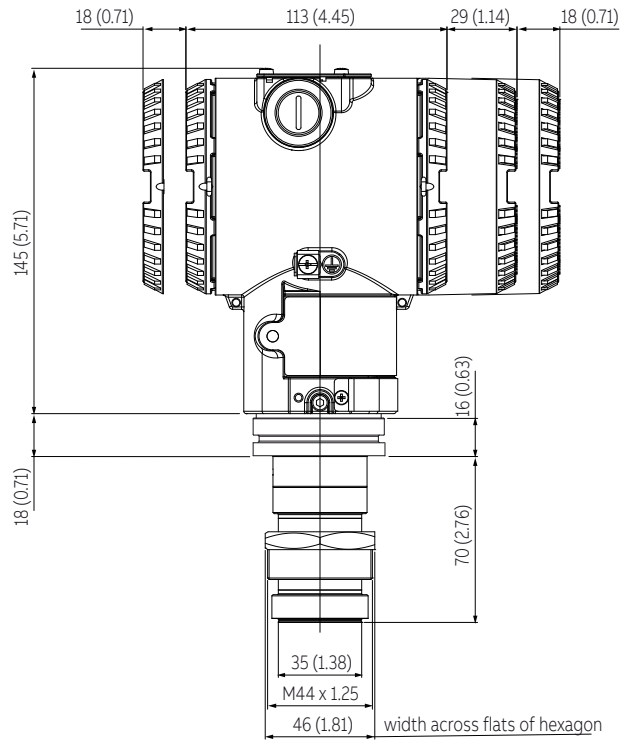

Figure 60 266HRH / 266NRH with barrel housing and direct mount seal S26KN pulp and paper to threaded spud

...Dimensions

The S26WA and S26WE wafer remote seals are designed to be clamped between two ASME or EN raised face flanges. The diaphragm side of the seal faces the process flange and a blind back-up flange is used on the other side of the seal.

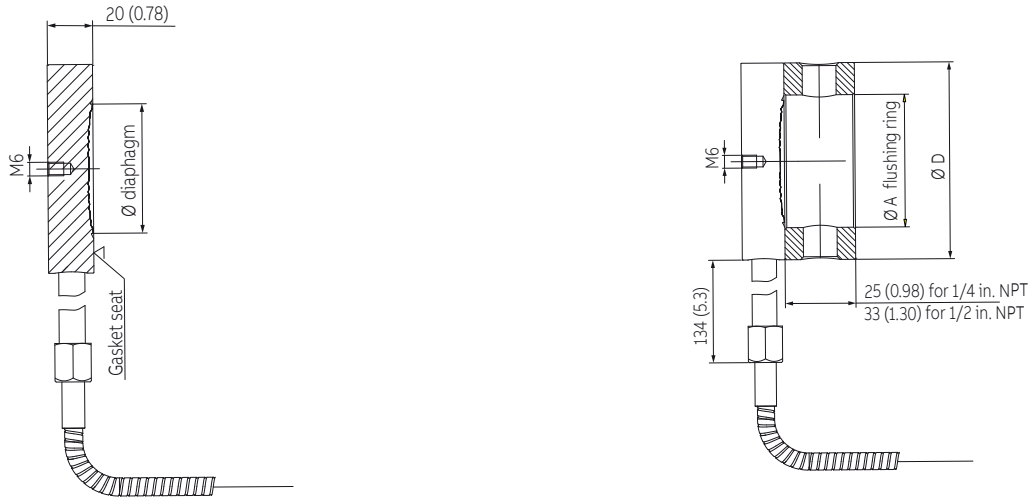

Figure 61 S26WA, S26WE Model Wafer remote diaphragm seal ASME and EN 1092-1 Form B1 smooth and serrated (flushing ring as option)

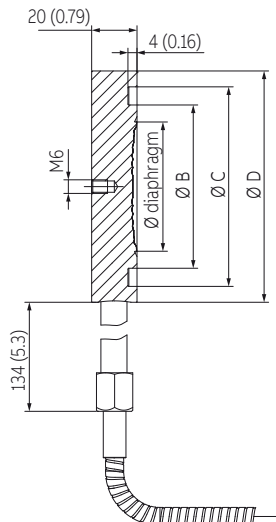

Figure 62 S26WA, S26WE Model Wafer remote diaphragm seal EN 1092-1 Form D

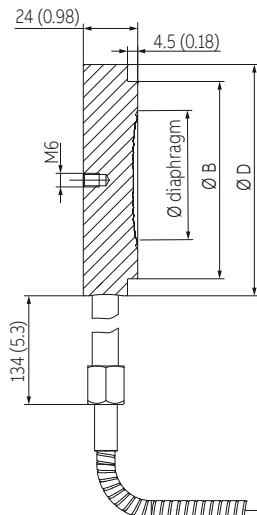

Figure 63 S26WA, S26WE Model Wafer remote diaphragm seal EN 1092-1 Form E

Size/Rating	Dimensions mm. (in.) for S26W					
	diaphragm (dia) std. thickness	diaphragm (dia) low thickness	A flushing ring internal dia	B (dia)	C (dia)	D (dia)
1 1/2 in. ASME B16.5	47 (1.85)	47 (1.85)	52 (2.05)	NA	NA	73 (2.87)
2 in. ASME B16.5	60 (2.36)	58 (2.28)	62 (2.44)	NA	NA	92 (3.62)
3 in. ASME B16.5	89 (3.5)	75 (2.95)	92 (3.62)	NA	NA	127 (5)
DN 40 EN 1092-1 Form B1	47 (1.85)	47 (1.85)	52 (2.05)	NA	NA	88 (3.46)
DN 50 EN 1092-1 Form B1	60 (2.36)	58 (2.28)	62 (2.44)	NA	NA	102 (4.02)
DN 80 EN 1092-1 Form B1	89 (3.5)	75 (2.95)	92 (3.62)	NA	NA	138 (5.43)
DN 40 EN 1092-1 Form D	47 (1.85)	47 (1.85)	NA	60 (2.36)	76 (2.99)	88 (3.46)
DN 50 EN 1092-1 Form D	60 (2.36)	58 (2.28)	NA	72 (2.83)	88 (3.46)	102 (4.02)
DN 80 EN 1092-1 Form D	89 (3.5)	75 (2.95)	NA	105 (4.13)	121 (4.76)	138 (5.43)
DN 40 EN 1092-1 Form E	47 (1.85)	47 (1.85)	NA	75 (2.95)	NA	88 (3.46)
DN 50 EN 1092-1 Form E	60 (2.36)	58 (2.28)	NA	87 (3.42)	NA	102 (4.02)
DN 80 EN 1092-1 Form E	89 (3.5)	75 (2.95)	NA	120 (4.72)	NA	138 (5.43)

The S26CN chemical tee remote seal is designed to connect to a Wedge Flow Element or to any process fitting with appropriate mating condition. Chemical tee elements cannot be connected to a standard ASME pipe flange.

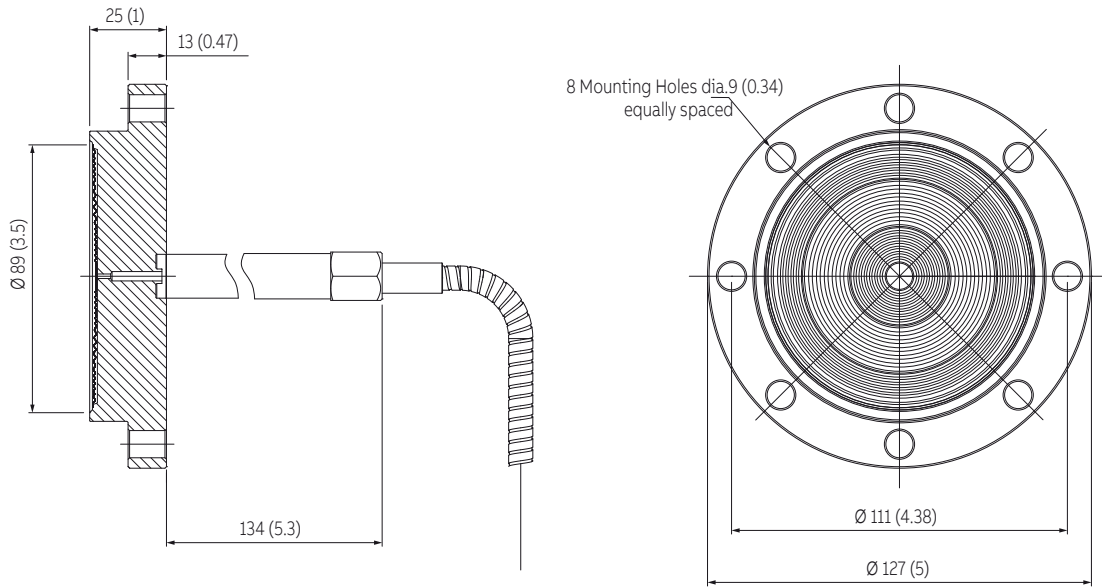

Figure 64 S26CN Model Chemical Tee remote diaphragm seal

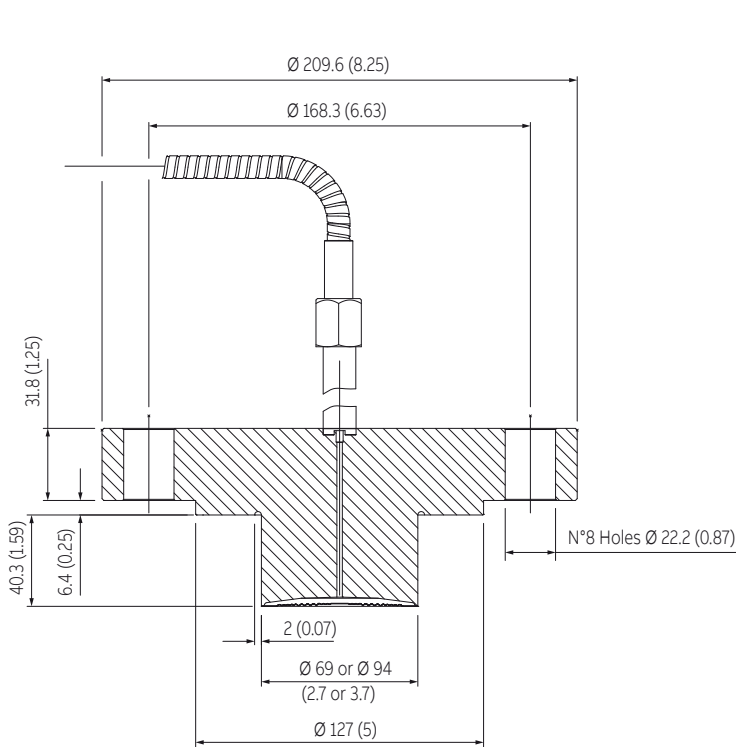

Figure 65 S26PN Model 2 1/2 in. urea service seal Flange ASME 600, 3 in.

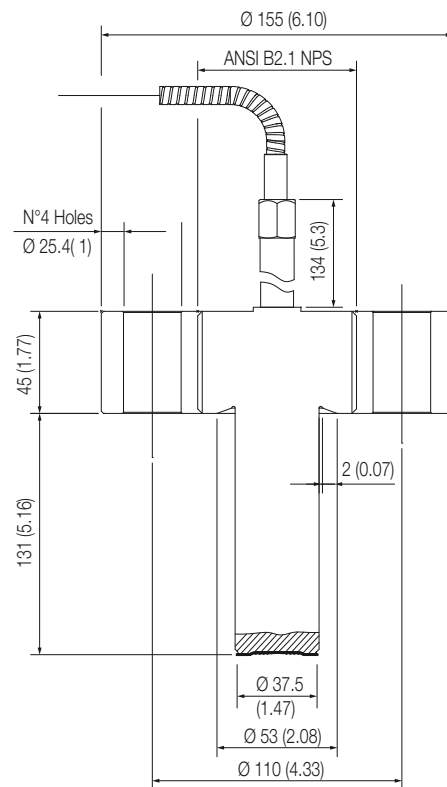

Figure 66 S26PN Model 1 1/2 in. urea service seal Flange ASME 2500, 2 in.

...Dimensions

The S26BN remote seals are designed to connect directly to a process pipe via the NPT threaded connection or to match pipe fitting with an interface suitable for the provided mating flange. The button seals, due to their design, are dedicated for measurement with medium/high calibrated span (2 MPa/20 bar/290 psi approx. or greater).

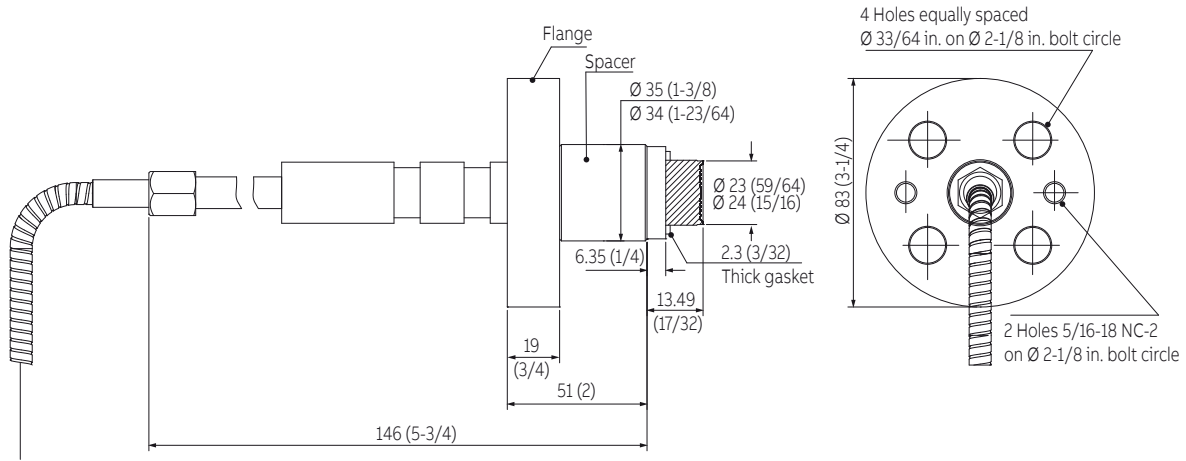

Figure 67 S26BN Model Button type remote diaphragm seal 3 1/4 in. flange extended - type 91

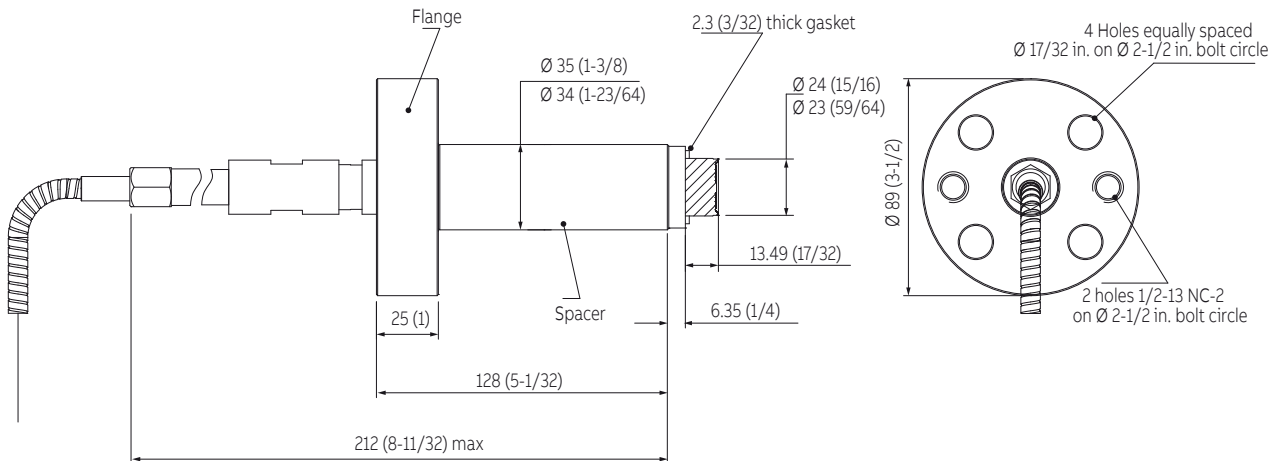

Figure 68 S26BN Model Button type remote diaphragm seal 3 1/2 in. flange extended - type 91 modified

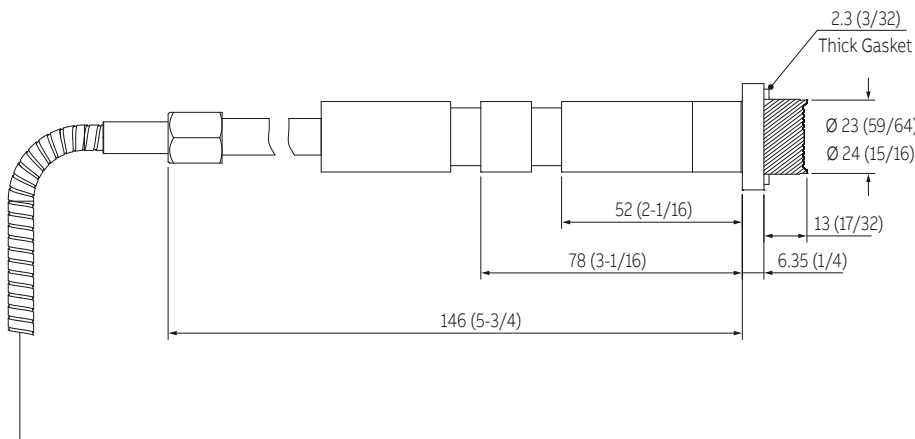

Figure 69 S26BN Model Button type remote diaphragm seal Universal - type 90

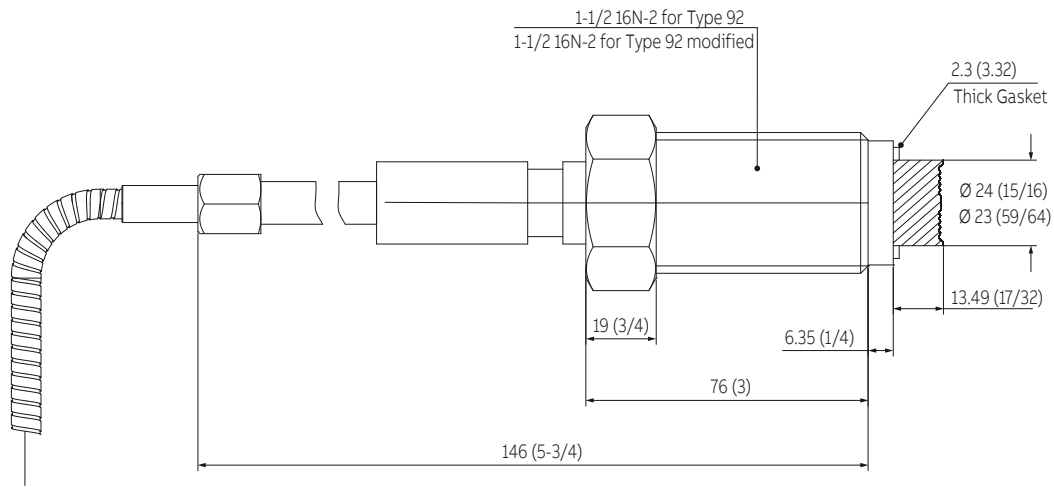

Figure 70 S26BN Model Button type remote diaphragm seal 1 1/2 in. threaded union type 92/92 modified

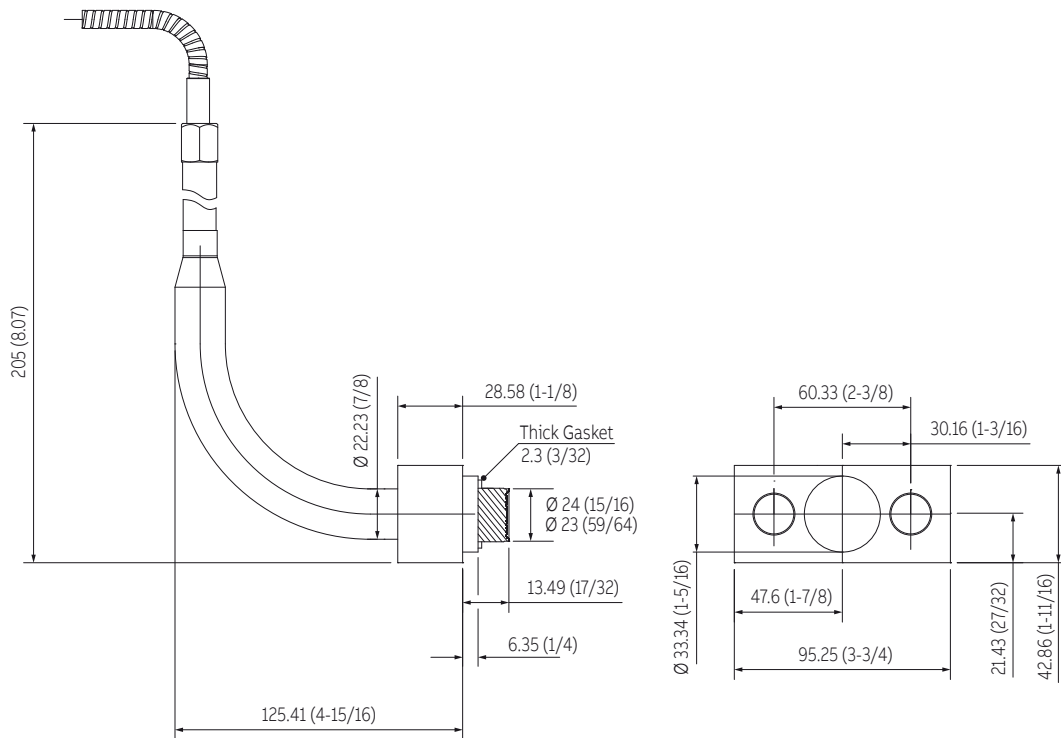

Figure 71 S26BN Model Button type remote diaphragm seal Bracket – type 89

...Dimensions

The union connection remote seals model S26BN are used exclusively for pressure measurement with gauge pressure transmitter.

The seal is available with an optional weld bushing, or with an optional chemical tee flange. The remote seal with a weld bushing, includes a bushing which provides the mating surface for the seal element. The union connection seal with a chemical tee flange, is designed to connect to any process fitting which accepts a chemical tee seal element (refer to Chemical Tee Seal for more information). The union seal connects to the chemical tee flange which serves as an adaptor to permit connection of the union seal to a chemical tee type fitting.

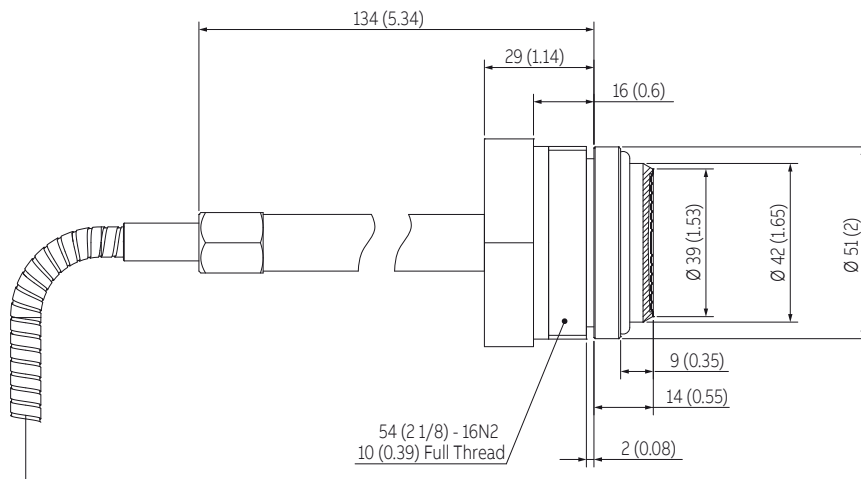

Figure 72 Union connection remote seal - basic version

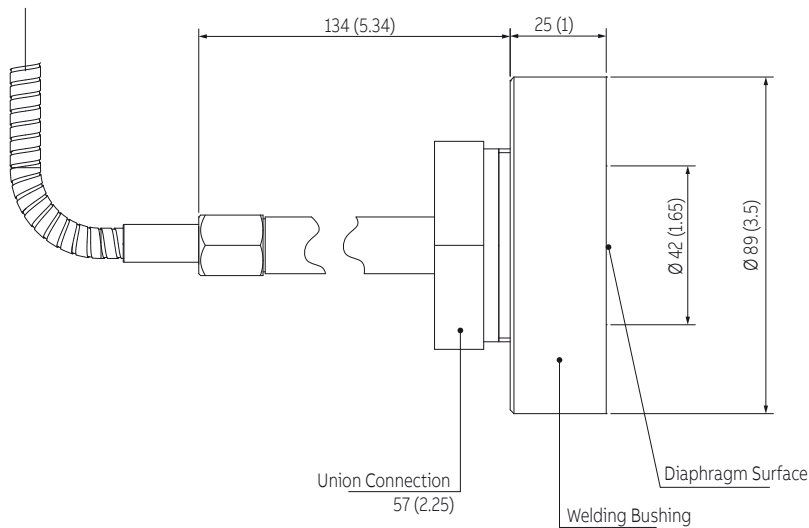

Figure 73 Union connection remote seal with weld bushing

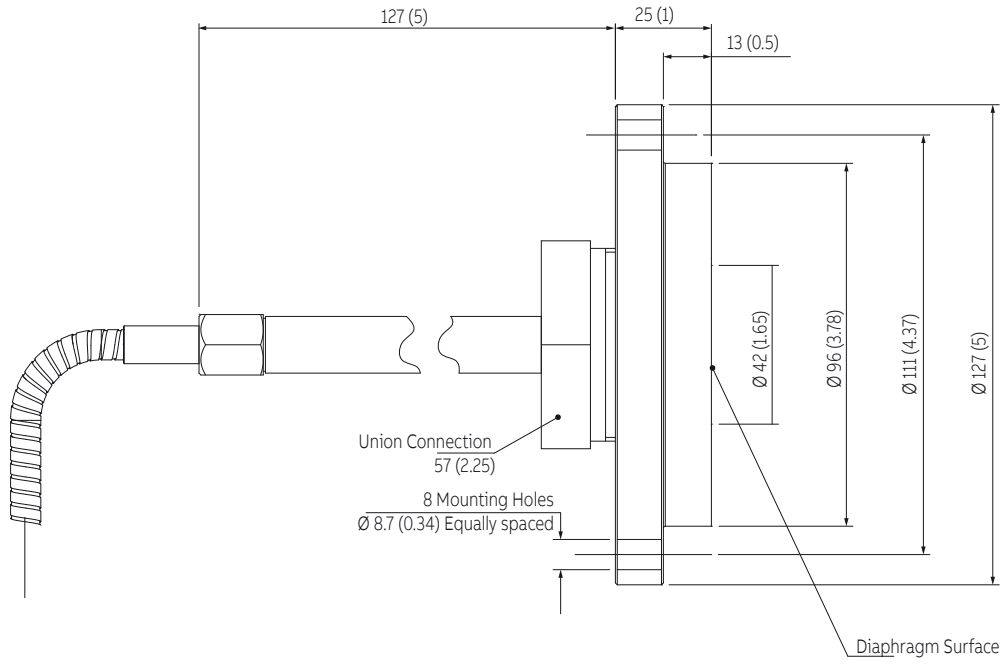
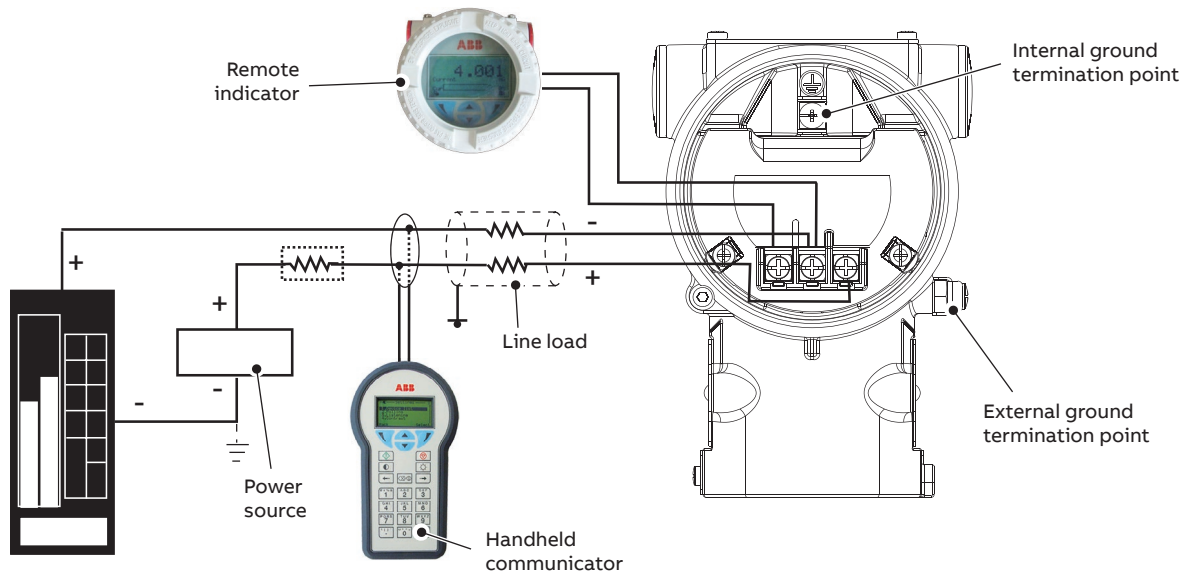

Figure 74 Union connection remote seal with Chemical Tee flange

Electrical connections



HART hand-held communicator may be connected at any wiring termination point in the loop, providing the minimum resistance is 250 ohm. If this is less than 250 ohm, additional resistance should be added to allow communications. Maximum voltage drop on external remote indicator is 0.7 V DC.

Figure 75 HART Version

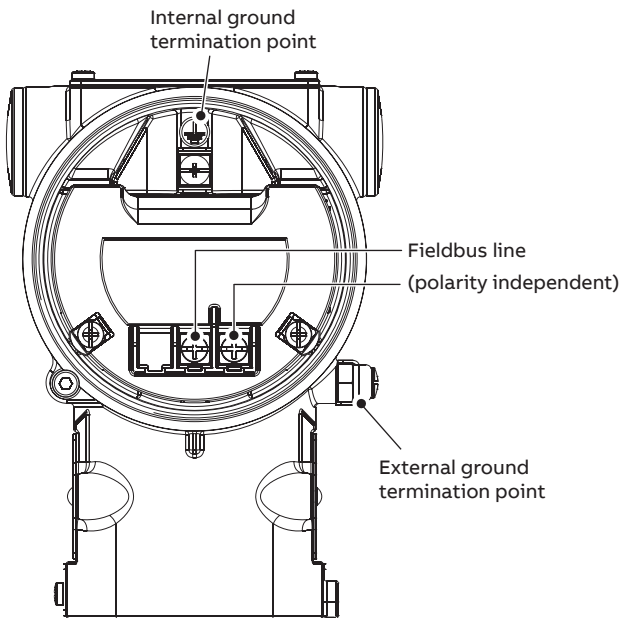

Figure 76 FIELDBUS Versions

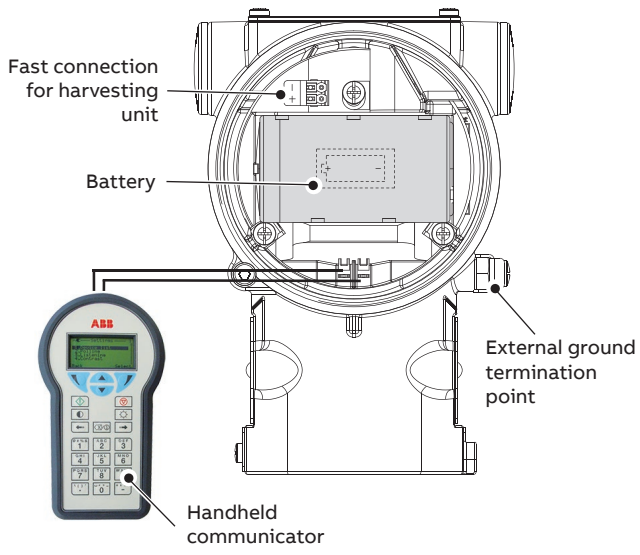

Figure 77 WirelessHART version

Ordering Information

Basic ordering information for model 266DRH Differential Pressure Transmitter with remote seal

Select one character or set of characters from each category and specify complete catalog number.

Refer to additional ordering information and specify one or more codes for each transmitter if additional options are required.

BASE MODEL - 1st to 6th characters				2 6 6 D R H	X	X	X	X	X	X	X
Differential Pressure Transmitter with remote seal- BASE ACCURACY 0.06 %											
SENSOR - Span limits - 7th character											
0.2 and 4 kPa	2 and 40 mbar	0.8 and 16 inH2O	(Note 11)	B							
0.8 and 16 kPa	8 and 160 mbar	3.2 and 64 inH2O	(Note 11)	E							
0.67 and 40 kPa	6.7 and 400 mbar	2.67 and 160 inH2O		F							
2.67 and 160 kPa	26.7 and 1600 mbar	10.7 and 642 inH2O		H							
10 and 600 kPa	0.1 and 6 bar	1.45 and 87 psi		M							
40 and 2400 kPa	0.4 and 24 bar	5.8 and 348 psi		P							
134 and 8000 kPa	1.34 and 80 bar	19.4 and 1160 psi		Q							
267 and 16000 kPa	2.67 and 160 bar	38.7 and 2320 psi	(Note 11)	S							
Application - 8th character											
Differential measurement at standard static pressure											S
Differential measurement at high static pressure (NOT AVAILABLE WITH DIRECT MOUNT SEALS)											H
Gauge measurement											(Note 3) P
Diaphragm material / Fill fluid (wetted parts) - 9th character											
AISI 316 L ss	Silicone oil	(one seal only to be quoted)	(Notes 3, 11)	NACE							S
Hastelloy® C-276	Silicone oil	(one seal only to be quoted)	(Notes 3, 11, 19)	NACE							K
Monel 400®	Silicone oil	(one seal only to be quoted)	(Notes 3, 11, 19)	NACE							M
Tantalum	Silicone oil	(one seal only to be quoted)	(Notes 3, 11, 19)	NACE							T
AISI 316 L ss	Inert fluid - Galden	(one seal only to be quoted)	(Notes 1, 3, 11)	NACE							A
Hastelloy® C-276	Inert fluid - Galden	(one seal only to be quoted)	(Notes 1, 3, 11, 19)	NACE							F
Monel 400®	Inert fluid - Galden	(one seal only to be quoted)	(Notes 1, 3, 11, 19)	NACE							C
Tantalum	Inert fluid - Galden	(one seal only to be quoted)	(Notes 1, 3, 11, 19)	NACE							D
AISI 316 L ss	Inert fluid - Halocarbon	(one seal only to be quoted)	(Notes 1, 3, 11)	NACE							L
Hastelloy® C-276	Inert fluid - Halocarbon	(one seal only to be quoted)	(Notes 1, 3, 11, 19)	NACE							P
Monel 400®	Inert fluid - Halocarbon	(one seal only to be quoted)	(Notes 1, 3, 11, 19)	NACE							4
Tantalum	Inert fluid - Halocarbon	(one seal only to be quoted)	(Notes 1, 3, 11, 19)	NACE							5
AISI 316 L ss (not wetted)	Silicone oil	(two seals to be quoted)	(Notes 2, 19)	NACE							R
AISI 316 L ss (not wetted)	Inert fluid - Galden	(two seals to be quoted)	(Notes 1, 3, 11, 19)	NACE							2
AISI 316 L ss (not wetted)	Inert fluid - Halocarbon	(two seals to be quoted)	(Notes 1, 3, 19)	NACE							W

continued
see next page

...Basic ordering information for model 266DRH Differential Pressure Transmitter

BASIC ORDERING INFORMATION model 266DRH Differential Pressure Transmitter				2	6	D	R	H	X	X	X	X
Process flanges/adapters material and connection (wetted parts) - 10th character												
AISI 316 L ss for two seals construction		(Notes 4, 19)	NACE						R			
AISI 316 L ss (Horizontal connection)	1/4 in. – 18 NPT-f direct	(Note 5)	NACE						A			
AISI 316 L ss (Horizontal connection)	1/2 in. – 14 NPT-f through adapter	(Notes 5, 19)	NACE						B			
Hastelloy® C-276 (Horizontal connection)	1/4 in. – 18 NPT-f direct	(Notes 5, 6, 19)	NACE						D			
Hastelloy® C-276 (Horizontal connection)	1/2 in. – 14 NPT-f through adapter	(Notes 5, 6, 19)	NACE						E			
Monel 400® (Horizontal connection)	1/4 in. – 18 NPT-f direct	(Notes 5, 6, 19)	NACE						G			
Monel 400® (Horizontal connection)	1/2 in. – 14 NPT-f through adapter	(Notes 5, 6, 19)	NACE						H			
Bolts/Gasket (wetted parts) - 11th character												
AISI 316 ss for standard static without gaskets for two seals construction (MWP = 16 MPa)		(Notes 4, 19)	NACE						R			
Stainless steel for high static without gaskets for two seals construction (MWP = 42 MPa)		(Notes 4, 19)	NACE						R			
AISI 316 ss without gaskets for two seals construction		(Notes 4, 19)	NACE (non exposed)						S			
AISI 316 ss	Viton®	(Note 5)	NACE (non exposed)						1			
AISI 316 ss	PTFE	(Notes 1, 5, 19)	NACE (non exposed)						2			
AISI 316 ss (NACE) – (MWP = 16 MPa)	Viton®	(Note 5)	NACE						3			
AISI 316 ss (NACE) – (MWP = 16 MPa)	PTFE	(Notes 1, 5, 19)	NACE						4			
Housing material and electrical connection - 12th character												
Aluminium alloy (barrel version)	1/2 in. – 14 NPT						(Note 14)					A
Aluminium alloy (barrel version)	M20 x 1.5 (CM 20)		(TO BE USED for WirelessHART)									B
AISI 316 L ss (barrel version) (I2 or I3 required)	1/2 in. – 14 NPT						(Note 14)					S
AISI 316 L ss (barrel version) (I2 or I3 required)	M20 x 1.5 (CM20)		(TO BE USED for WirelessHART)									T
Aluminium alloy (DIN version)	M20 x 1.5 (CM20)		(not Ex d or XP)				(Note 14)					J
Output/Additional options - 13th character												
HART and 4 to 20 mA - Standard functionality												7
HART and 4 to 20 mA - Advanced functionality (includes option R1)												1
PROFIBUS PA (includes option R1)												2
FOUNDATION Fieldbus (includes option R1)												3
HART and 4 to 20 mA Safety, certified to IEC 61508 (includes option R1)												8
WirelessHART (includes option R1)							(Note 13)					9

...Ordering information

Additional ordering information for model 266DRH Differential Pressure Transmitter

Add one or more 2–digit code(s) after the basic ordering information to select all required options.

				XX	XX	XX
Improved performance						
Temperature errors optimization				DE		
Drain/vent valve (material and position) (wetted parts)						
AISI 316 L ss	on process axis	(Note 7)	NACE			V1
AISI 316 L ss	on flange side top	(Note 7)	NACE			V2
AISI 316 L ss	on flange side bottom	(Note 7)	NACE			V3
Hastelloy® C-276	on process axis	(Note 8)	NACE			V4
Hastelloy® C-276	on flange side top	(Note 8)	NACE			V5
Hastelloy® C-276	on flange side bottom	(Note 8)	NACE			V6
Monel 400®	on process axis	(Note 9)	NACE			V7
Monel 400®	on flange side top	(Note 9)	NACE			V8
Monel 400®	on flange side bottom	(Note 9)	NACE			V9
Hazardous area certifications (see relevant paragraph for complete detailed markings)						
ATEX Intrinsic Safety Ex ia						E1
ATEX Explosion Proof Ex db					(Notes 10, 14)	E2
ATEX Intrinsic Safety Ex ic					(Note 14)	E3
Combined ATEX, IECEx, FM Approvals (USA) and FM Approvals (Canada)					(Notes 10, 14)	EN
FM Approvals (Canada) approval (XP, DIP, IS, NI, Type N)					(Notes 10, 14)	E4
FM Approvals (USA) approval (XP, DIP, IS, NI, Type N)					(Notes 10, 14)	E6
FM Approvals (USA and Canada) Intrinsic Safety						EA
IECEx Intrinsic Safety Ex ia						E8
IECEx Explosion Proof Ex db					(Notes 10, 14)	E9
IECEx Intrinsic Safety Ex ic					(Note 14)	ER
NEPSI Intrinsic Safety Ex ia					(Note 14)	EY
NEPSI Explosion Proof Ex d					(Notes 10, 14)	EZ
NEPSI Intrinsic Safety Ex ic					(Note 14)	ES

...Additional ordering information for model 266DRH Differential Pressure Transmitter

	XX	XX	XX	XX	XX
Other hazardous area certifications (ONLY AS ALTERNATIVE TO BASIC CERTIFICATION CODE Ex)					
Technical Regulations Customs Union (EAC) Intrinsic Safety Ex ia for Russia (Note 14)	W1				
Technical Regulations Customs Union (EAC) Explosion Proof Ex d for Russia (Notes 10, 14)	W2				
Technical Regulations Customs Union (EAC) combined Ex ia and Ex d for Russia (Notes 10, 14)	WC				
Technical Regulations Customs Union (EAC) Intrinsic Safety Ex ia for Kazakhstan (Note 14)	W3				
Technical Regulations Customs Union (EAC) Explosion Proof Ex d for Kazakhstan (Notes 10, 14)	W4				
Technical Regulations Customs Union (EAC) combined Ex ia and Ex d for Kazakhstan (Notes 10, 14)	WD				
Inmetro (Brazil) Intrinsic Safety Ex ia (Note 14)	W5				
Inmetro (Brazil) Explosion Proof Ex d (Notes 10, 14)	W6				
Inmetro (Brazil) Intrinsic Safety Ex ic (Note 14)	W7				
Combined Inmetro (Brazil) - Intrinsic Safety Ex ia, Explosion Proof and Intrinsic Safety Ex ic (Notes 10, 14)	W8				
Technical Regulations Customs Union (EAC) Intrinsic Safety Ex ia for Belarus (Note 14)	WF				
Technical Regulations Customs Union (EAC) Explosion Proof Ex d for Belarus (Notes 10, 14)	WG				
Technical Regulations Customs Union (EAC) combined Ex ia and Ex d for Belarus (Notes 10, 14)	WH				
Kosha (Korea) Intrinsic Safety Ex ia IIC T6, IP67 (Notes 12, 14)	WM				
Kosha (Korea) Explosion Proof Ex d IIC T6, IP67 (Notes 10, 12, 14)	WN				
Combined Kosha (Korea) - Intrinsic Safety and Explosion Proof (Notes 10, 12, 14)	WP				
Integral LCD					
Digital LCD integral display (Note 12)	L1				
TTG (Through-The-Glass) digital LCD controlled display (Note 12)	L5				
Integrated digital LCD display (ONLY SELECTABLE WITH OUTPUT CODE 7) (Note 17)	LS				
External non intrusive Z, S and WP pushbuttons					
Transmitters with external pushbutton (ONLY SELECTABLE WITH OUTPUT CODE 7)					R1
Mounting bracket (shape and material)					
For pipe/wall mounting - Carbon steel (Not suitable for AISI housing)					B1
For pipe/wall mounting - AISI 316 L ss					B2
Flat type for box - AISI 316 ss					B5
Surge					
Surge/Transient Protector (Note 14)					S2

...Ordering Information

...Additional ordering information for model 266DRH Differential Pressure Transmitter

	XX	XX	XX	XX	XX
Operating manual (multiple selection allowed)					
German (FOR HART, WirelessHART and PROFIBUS VERSIONS)	M1				
Italian (ONLY FOR HART VERSIONS)	M2				
Spanish (FOR HART, WirelessHART and FOUNDATION Fieldbus VERSIONS)	M3				
French (ONLY FOR HART VERSIONS)	M4				
English	M5				
Portuguese (ONLY FOR HART VERSIONS)	MA				
Russian (ONLY FOR HART VERSIONS)	MB				
Plates language					
German		T1			
Italian		T2			
Spanish		T3			
French		T4			
Additional tag plate					
Supplemental wired-on stainless steel plate				I1	
Tag and certification stainless steel plates and laser printing of tag				I2	
Tag, certification and supplemental wired-on stainless steel plates and laser printing of tag				I3	
Configuration					
Standard – Pressure = inH2O/ psi at 68 °F; Temperature = deg. F					N2
Standard – Pressure = inH2O/ psi at 39.2 °F; Temperature = deg. F					N3
Standard – Pressure = inH2O/ psi at 20 °C; Temperature = deg. C					N4
Standard – Pressure = inH2O/ psi at 4 °C; Temperature = deg. C					N5
Custom					N6
Configured for HART revision 5		(Note 20)			NH
Certificates (multiple selection allowed)					
Inspection certificate EN 10204–3.1 of calibration (9-point)					C1
Inspection certificate EN 10204–3.1 of helium leakage test of the sensor module					C4
Inspection certificate EN 10204–3.1 of the pressure test					C5
Certificate of compliance with the order EN 10204–2.1 of instrument design					C6
PMI test of wetted parts					CT

...Additional ordering information for model 266DRH Differential Pressure Transmitter

	XX	XX	XX	XX	XX
Approvals					
Metrologic Pattern for Russia (NOT APPLICABLE WITH ANY HAZARDOUS AREA CERTIFICATION)	Y1				
Metrologic Pattern for Kazakhstan (NOT APPLICABLE WITH ANY HAZARDOUS AREA CERTIFICATION)	Y2				
Metrologic Pattern for Belarus (NOT APPLICABLE WITH ANY HAZARDOUS AREA CERTIFICATION)	Y4				
Chinese pattern (NOT APPLICABLE WITH ANY HAZARDOUS AREA CERTIFICATION)	Y5				
DNV GL approval (Notes 12, 14)		YA			
Conformity to NAMUR NE 021 (2004) (NOT APPLICABLE WITH SURGE PROTECTOR CODE "S2") (Notes 12, 14, 16, 18)		YE			
CRN (Canadian Registration Number OF14838.5C)		YR			
Material traceability					
Inspection certificate EN 10204–3.1 of process wetted parts (not for gaskets)				H3	
Test report EN 10204–2.2 of pressure bearing and process wetted parts (not for gaskets)				H4	
National radio frequency licence					
Basic countries (Europe, USA, Canada) (Note 15)					FB
Argentina (Note 15)					FA
United Arab Emirates (Note 15)					FG
India (Note 15)					FI
Mexico (Note 15)					FM
Electrical connection plug					
One certified stainless steel plug (supplied loose with thread according to housing entries)					Z1

Note 1: Suitable for oxygen service

Note 2: Not wetted – Hastelloy C276 on AISI seat for sensor code B

Note 3: Not available with sensor code B

Note 4: Not available with low side diaphragm code S, K, M, T, A, F, C, D, L, P, 4, 5

Note 5: Not available with low side diaphragm code R, 2, W

Note 6: Not available with diaphragm material/fill fluid code S, A, L

Note 7: Not available with Process flanges/adapters code D, E, G, H, R

Note 8: Not available with Process flanges/adapters code A, B, G, H, R

Note 9: Not available with Process flanges/adapters code A, B, D, E, R

Note 10: Not available with Housing code J

Note 11: Not available with high static pressure code H

Note 12: Not available with Output code 7

Note 13: Not available with Housing code A, S, J

Note 14: Not available with Output code 9

Note 15: Not available with Output code 1, 2, 3, 7, 8

Note 16: Not available with Output code 2, 3

Note 17: Not available with Hazardous area certification code WM, WN, WP

Note 18: Not available with Hazardous area certification code EN, E4, E6, EA, EY, EZ, ES, W1, W2, WC, W3, W4, WD, W5, W6, W7, W8, WF, WG, WH, WM, WN, WP

Note 19: Not available with Application code P (gauge measurement)

Note 20: Not available with Output code 2, 3, 9

Standard delivery items (can be differently specified by additional ordering code)

- Adapter supplied loose
- Plug on axis of horizontal connection flange
- General purpose (no electrical certification)
- No display, no mounting bracket, no surge protection
- Multilanguage short-form operating instruction manual and labels in english (metal nameplate; self-adhesive certification and tag)
- Configuration with kPa and deg. C units
- No test, inspection or material traceability certificates

...Ordering Information

Basic ordering information for model 266HRH Gauge Pressure Transmitter with remote seal

Select one character or set of characters from each category and specify complete catalog number.

Refer to additional ordering information and specify one or more codes for each transmitter if additional options are required.

BASE MODEL - 1st to 6th characters			2 6 6 H R H		X	X	X	X	X
Gauge Pressure Transmitter with remote seal – BASE ACCURACY 0.06 %									
SENSOR - Span limits - 7th character									
0.67 and 40 kPa	6.7 and 400 mbar	2.67 and 160 inH2O			F				
2.67 and 160 kPa	26.7 and 1600 mbar	10.7 and 642 inH2O			H				
10 and 600 kPa	0.1 and 6 bar	1.45 and 87 psi			M				
40 and 2400 kPa	0.4 and 24 bar	5.8 and 348 psi			P				
134 and 8000 kPa	1.34 and 80 bar	19.4 and 1160 psi			Q				
267 and 16000 kPa	2.67 and 160 bar	38.7 and 2320 psi			S				
1400 and 70000 kPa	14 and 700 bar	203 and 10150 psi			W				
10500 and 105000 kPa	105 and 1050 bar	1522 and 15225 psi			Z				
Diaphragm material / Fill fluid - 8th character									
AISI 316 L ss		Silicone oil	(Note 5)	NACE				R	
AISI 316 L ss		Inert fluid - Galden	(Notes 1, 2, 5)	NACE				2	
AISI 316 L ss		Inert fluid - Halocarbon	(Notes 1, 2, 5)	NACE				W	
Inconel® 718		No filling	(Notes 2, 6)					U	
Process connection - 9th character									
Remote or direct mount seal		(one seal to be quoted separately)							R
Housing material and electrical connection - 10th character									
Aluminium alloy (barrel version)		1/2 in. – 14 NPT		(Note 8)					A
Aluminium alloy (barrel version)		M20 x 1.5 (CM 20)		(TO BE USED for WirelessHART)					B
AISI 316 L ss (barrel version) (I2 or I3 required)		1/2 in. – 14 NPT		(Note 8)					S
AISI 316 L ss (barrel version) (I2 or I3 required)		M20 x 1.5 (CM20)		(TO BE USED for WirelessHART)					T
Aluminium alloy (DIN version)		M20 x 1.5 (CM20)		(not Ex d or XP)				(Note 8)	J
Output/Additional options - 11th character									
HART and 4 to 20 mA - Standard functionality				(Notes 2, 5)					7
HART and 4 to 20 mA - Advanced functionality (includes option R1)									1
PROFIBUS PA (includes option R1)									2
FOUNDATION Fieldbus (includes option R1)									3
HART and 4 to 20 mA Safety, certified to IEC 61508 (includes option R1)									8
WirelessHART (includes option R1)				(Notes 2, 5, 7)					9

NOTE - Option R1 represents the external pushbuttons

Additional ordering information for model 266HRH Gauge Pressure Transmitter with remote seal

Add one or more 2–digit code(s) after the basic ordering information to select all required options.

			XX
Hazardous area certifications (see relevant paragraph for complete detailed markings)			
ATEX Intrinsic Safety Ex ia			E1
ATEX Explosion Proof Ex db	(Notes, 3, 8)		E2
ATEX Intrinsic Safety Ex ic	(Note 8)		E3
Combined ATEX, IECEx, FM Approvals (USA) and FM Approvals (Canada)	(Notes, 3, 8)		EN
FM Approvals (Canada) approval (XP, DIP, IS, NI, Type N)	(Notes, 3, 8)		E4
FM Approvals (USA) approval (XP, DIP, IS, NI, Type N)	(Notes, 3, 8)		E6
FM Approvals (USA and Canada) Intrinsic Safety			EA
IECEx Intrinsic Safety Ex ia			E8
IECEx Explosion Proof Ex db	(Notes, 3, 8)		E9
IECEx Intrinsic Safety Ex ic	(Note 8)		ER
NEPSI Intrinsic Safety Ex ia	(Note 8)		EY
NEPSI Explosion Proof Ex d	(Notes, 3, 8)		EZ
NEPSI Intrinsic Safety Ex ic	(Note 8)		ES
Other hazardous area certifications (ONLY AS ALTERNATIVE TO BASIC CERTIFICATION CODE Ex)			
Technical Regulations Customs Union (EAC) Intrinsic Safety Ex ia for Russia	(Note 8)		W1
Technical Regulations Customs Union (EAC) Explosion Proof Ex d for Russia	(Notes, 3, 8)		W2
Technical Regulations Customs Union (EAC) combined Ex ia and Ex d for Russia	(Notes, 3, 8)		WC
Technical Regulations Customs Union (EAC) Intrinsic Safety Ex ia for Kazakhstan	(Note 8)		W3
Technical Regulations Customs Union (EAC) Explosion Proof Ex d for Kazakhstan	(Notes, 3, 8)		W4
Technical Regulations Customs Union (EAC) combined Ex ia and Ex d for Kazakhstan	(Notes, 3, 8)		WD
Inmetro (Brazil) Intrinsic Safety Ex ia	(Note 8)		W5
Inmetro (Brazil) Explosion Proof Ex d	(Notes, 3, 8)		W6
Inmetro (Brazil) Intrinsic Safety Ex ic	(Note 8)		W7
Combined Inmetro (Brazil) - Intrinsic Safety Ex ia, Explosion Proof and Intrinsic Safety Ex ic	(Notes, 3, 8)		W8
Technical Regulations Customs Union (EAC) Intrinsic Safety Ex ia for Belarus	(Note 8)		WF
Technical Regulations Customs Union (EAC) Explosion Proof Ex d for Belarus	(Notes, 3, 8)		WG
Technical Regulations Customs Union (EAC) combined Ex ia and Ex d for Belarus	(Notes, 3, 8)		WH
Kosha (Korea) Intrinsic Safety Ex ia IIC T6, IP67	(Notes 2, 4, 8)		WM
Kosha (Korea) Explosion Proof Ex d IIC T6, IP67	(Notes 2, 3, 4, 8)		WN
Combined Kosha (Korea) - Intrinsic Safety and Explosion Proof	(Notes 2, 3, 4, 8)		WP

...Additional ordering information for model 266HRH Gauge Pressure Transmitter with remote seal

	XX	XX	XX	XX	XX	XX
Certificates (multiple selection allowed)						
Inspection certificate EN 10204–3.1 of calibration (9-point)	C1					
Inspection certificate EN 10204–3.1 of the pressure test	C5					
Certificate of compliance with the order EN 10204–2.1 of instrument design	C6					
PMI test of wetted parts	CT					
Approvals						
Metrologic Pattern for Russia (NOT APPLICABLE WITH ANY HAZARDOUS AREA CERTIFICATION)	Y1					
Metrologic Pattern for Kazakhstan (NOT APPLICABLE WITH ANY HAZARDOUS AREA CERTIFICATION)	Y2					
Metrologic Pattern for Belarus (NOT APPLICABLE WITH ANY HAZARDOUS AREA CERTIFICATION)	Y4					
Chinese pattern (NOT APPLICABLE WITH ANY HAZARDOUS AREA CERTIFICATION)	Y5					
DNV GL approval (Notes 2, 4, 5, 8)	YA					
Conformity to NAMUR NE 021 (2004) (NOT APPLICABLE WITH SURGE PROTECTOR CODE "S2") (Notes 2, 4, 5, 8, 10, 12)	YE					
CRN (Canadian Registration Number OF14838.5C)	YR					
Material traceability						
Inspection certificate EN 10204–3.1 of process wetted parts (not for gaskets)					H3	
Test report EN 10204–2.2 of pressure bearing and process wetted parts (not for gaskets)					H4	
National radio frequency licence						
Basic countries (Europe, USA, Canada) (Note 9)						FB
Argentina (Note 9)						FA
United Arab Emirates (Note 9)						FG
India (Note 9)						FI
Mexico (Note 9)						FM
Electrical connection plug						
One certified stainless steel plug (supplied loose with thread according to housing entries)						Z1

Note 1: Suitable for oxygen service
 Note 2: Not available with Sensor code W
 Note 3: Not available with Housing code J
 Note 4: Not available with Output code 7
 Note 5: Not available with Sensor code Z
 Note 6: Not available with Sensor code F to S
 Note 7: Not available with Housing code A, S, J
 Note 8: Not available with Output code 9
 Note 9: Not available with Output code 1, 2, 3, 7, 8
 Note 10: Not available with Output code 2, 3
 Note 11: Not available with Hazardous area certification code WM, WN, WP
 Note 12: Not available with Hazardous area certification code EN, E4, E6, EA, EY, EZ, ES, W1, W2, WC, W3, W4, WD, W5, W6, W7, W8, WF, WG, WH, WM, WN, WP
 Note 13: Not available with Output code 2, 3, 9

Standard delivery items (can be differently specified by additional ordering code)

- General purpose (no electrical certification)
- No display, no mounting bracket, no surge protection
- Multilanguage short-form operating instruction manual and labels in english (metal nameplate; self-adhesive certification and tag)
- Configuration with kPa and deg. C units
- No test, inspection or material traceability certificates

...Ordering Information

Basic ordering information for model 266NRH Absolute Pressure Transmitter with remote seal

Select one character or set of characters from each category and specify complete catalog number.

Refer to additional ordering information and specify one or more codes for each transmitter if additional options are required.

BASE MODEL - 1st to 6th characters				2 6 6 N R H	X	X	X	X	X
Absolute Pressure Transmitter with remote seal – BASE ACCURACY 0.10 %									
SENSOR - Span limits - 7th character									
0.67 and 40 kPa	6.7 and 400 mbar	5 and 300 mmHg		F					
2.67 and 160 kPa	26.7 and 1600 mbar	10.7 and 642 inH ₂ O		H					
10 and 600 kPa	0.1 and 6 bar	1.45 and 87 psi		M					
40 and 2400 kPa	0.4 and 24 bar	5.8 and 348 psi		P					
134 and 8000 kPa	1.34 and 80 bar	19.4 and 1160 psi		Q					
267 and 16000 kPa	2.67 and 160 bar	38.7 and 2320 psi		S					
Diaphragm material / Fill fluid - 8th character									
AISI 316 L ss		Silicone oil	NACE		R				
AISI 316 L ss		Inert fluid - Galden (Note 1)	NACE		2				
AISI 316 L ss		Inert fluid - Halocarbon (Note 1)	NACE		W				
Process connection - 9th character									
Remote or direct mount seal (one seal to be quoted separately)									R
Housing material and electrical connection - 10th character									
Aluminium alloy (barrel version)	1/2 in. – 14 NPT	(Note 5)							A
Aluminium alloy (barrel version)	M20 x 1.5 (CM 20)	(TO BE USED for WirelessHART)							B
AISI 316 L ss (barrel version) (I2 or I3 required)	1/2 in. – 14 NPT	(Note 5)							S
AISI 316 L ss (barrel version) (I2 or I3 required)	M20 x 1.5 (CM20)	(TO BE USED for WirelessHART)							T
Aluminium alloy (DIN version)	M20 x 1.5 (CM20)	(not Ex d or XP)	(Note 5)						J
Output/Additional options - 11th character									
HART and 4 to 20 mA - Standard functionality									7
HART and 4 to 20 mA - Advanced functionality (includes option R1)									1
PROFIBUS PA (includes option R1)									2
FOUNDATION Fieldbus (includes option R1)									3
HART and 4 to 20 mA Safety, certified to IEC 61508 (includes option R1)									8
WirelessHART (includes option R1)							(Note 4)		9

Additional ordering information for model 266NRH Absolute Pressure Transmitter with remote seal

Add one or more 2–digit code(s) after the basic ordering information to select all required options.

	XX
Hazardous area certifications (see relevant paragraph for complete detailed markings)	
ATEX Intrinsic Safety Ex ia	E1
ATEX Explosion Proof Ex db	(Notes, 2, 5) E2
ATEX Intrinsic Safety Ex ic	(Note 5) E3
Combined ATEX, IECEx, FM Approvals (USA) and FM Approvals (Canada)	(Notes, 2, 5) EN
FM Approvals (Canada) approval (XP, DIP, IS, NI, Type N)	(Notes, 2, 5) E4
FM Approvals (USA) approval (XP, DIP, IS, NI, Type N)	(Notes, 2, 5) E6
FM Approvals (USA and Canada) Intrinsic Safety	EA
IECEX Intrinsic Safety Ex ia	E8
IECEX Explosion Proof Ex db	(Notes, 2, 5) E9
IECEX Intrinsic Safety Ex ic	(Note 5) ER
NEPSI Intrinsic Safety Ex ia	(Note 5) EY
NEPSI Explosion Proof Ex d	(Notes, 2, 5) EZ
NEPSI Intrinsic Safety Ex ic	(Note 5) ES
Other hazardous area certifications (ONLY AS ALTERNATIVE TO BASIC CERTIFICATION CODE Ex)	
Technical Regulations Customs Union (EAC) Intrinsic Safety Ex ia for Russia	(Note 5) W1
Technical Regulations Customs Union (EAC) Explosion Proof Ex d for Russia	(Notes, 2, 5) W2
Technical Regulations Customs Union (EAC) combined Ex ia and Ex d for Russia	(Notes, 2, 5) WC
Technical Regulations Customs Union (EAC) Intrinsic Safety Ex ia for Kazakhstan	(Note 5) W3
Technical Regulations Customs Union (EAC) Explosion Proof Ex d for Kazakhstan	(Notes, 2, 5) W4
Technical Regulations Customs Union (EAC) combined Ex ia and Ex d for Kazakhstan	(Notes, 2, 5) WD
Inmetro (Brazil) Intrinsic Safety Ex ia	(Note 5) W5
Inmetro (Brazil) Explosion Proof Ex d	(Notes, 2, 5) W6
Inmetro (Brazil) Intrinsic Safety Ex ic	(Notes, 5) W7
Combined Inmetro (Brazil) - Intrinsic Safety Ex ia, Explosion Proof and Intrinsic Safety Ex ic	(Notes, 2, 5) W8
Technical Regulations Customs Union (EAC) Intrinsic Safety Ex ia for Belarus	(Note 5) WF
Technical Regulations Customs Union (EAC) Explosion Proof Ex d for Belarus	(Notes, 2, 5) WG
Technical Regulations Customs Union (EAC) combined Ex ia and Ex d for Belarus	(Notes, 2, 5) WH
Kosha (Korea) Intrinsic Safety Ex ia IIC T6, IP67	(Notes, 3, 5) WM
Kosha (Korea) Explosion Proof Ex d IIC T6, IP67	(Notes, 2, 3, 5) WN
Combined Kosha (Korea) - Intrinsic Safety and Explosion Proof	(Notes, 2, 3, 5) WP

...Additional ordering information for model 266NRH Absolute Pressure Transmitter with remote seal

	XX	XX	XX	XX	XX	XX
Certificates (multiple selection allowed)						
Inspection certificate EN 10204–3.1 of calibration (9-point)	C1					
Inspection certificate EN 10204–3.1 of the pressure test	C5					
Certificate of compliance with the order EN 10204–2.1 of instrument design	C6					
PMI test of wetted parts	CT					
Approvals						
Metrologic Pattern for Russia (NOT APPLICABLE WITH ANY HAZARDOUS AREA CERTIFICATION)		Y1				
Metrologic Pattern for Kazakhstan (NOT APPLICABLE WITH ANY HAZARDOUS AREA CERTIFICATION)		Y2				
Metrologic Pattern for Belarus (NOT APPLICABLE WITH ANY HAZARDOUS AREA CERTIFICATION)		Y4				
Chinese pattern (NOT APPLICABLE WITH ANY HAZARDOUS AREA CERTIFICATION)		Y5				
DNV GL approval (Notes 3, 5)			YA			
Conformity to NAMUR NE 021 (2004) (NOT APPLICABLE WITH SURGE PROTECTOR CODE “S2”) (Notes 3, 5, 7, 9)			YE			
CRN (Canadian Registration Number OF14838.5C)			YR			
Material traceability						
Inspection certificate EN 10204–3.1 of process wetted parts (not for gaskets)					H3	
Test report EN 10204–2.2 of pressure bearing and process wetted parts (not for gaskets)					H4	
National radio frequency licence						
Basic countries (Europe, USA, Canada) (Note 6)						FB
Argentina (Note 6)						FA
United Arab Emirates (Note 6)						FG
India (Note 6)						FI
Mexico (Note 6)						FM
Electrical connection plug						
One certified stainless steel plug (supplied loose with thread according to housing entries)						Z1

Note 1: Suitable for oxygen service

Note 2: Not available with Housing code J

Note 3: Not available with Output code 7

Note 4: Not available with Housing code A, S, J

Note 5: Not available with Output code 9

Note 6: Not available with Output code 1, 2, 3, 7, 8

Note 7: Not available with Output code 2, 3

Note 8: Not available with Hazardous area certification code WM, WN, WP

Note 9: Not available with Hazardous area certification code EN, E4, E6, EA, EY, EZ, ES, W1, W2, WC, W3, W4, WD, W5, W6, W7, W8, WF, WG, WH, WM, WN, WP

Note 10: Not available with Output code 2, 3, 9

Standard delivery items (can be differently specified by additional ordering code)

- General purpose (no electrical certification)
- No display, no mounting bracket, no surge protection
- Multilanguage short-form operating instruction manual and labels in english (metal nameplate; self-adhesive certification and tag)
- Configuration with kPa and deg. C units
- No test, inspection or material traceability certificates

...Ordering Information

Basic ordering information for model S26RA Rotating flange diaphragm seals (flush and extended) to ASME B16.5

Select one character or set of characters from each category and specify complete catalog number.

BASE MODEL - 1st to 5th characters	S 2 6 R A	X	XX	X	X	XX	X	X	X	X	X	X
Rotating flange diaphragm seal (Raised face flush and extended) to ASME B16.5												
Transmitter Side of Connection - 6th character												
High pressure side		H										
Low pressure side		L										
Mounting Flange Rating / Size - 7th and 8th characters												
ASME CL 150 / 2 in.			E1									
ASME CL 300 / 2 in.			E2									
ASME CL 600 / 2 in.			E3									
ASME CL 900-1500 / 2 in.			E5									
ASME CL 150 / 3 in.			G1									
ASME CL 300 / 3 in.			G2									
ASME CL 600 / 3 in.			G3									
ASME CL 900 / 3 in.			G4									
ASME CL 1500 / 3 in.			G5									
ASME CL 150 / 4 in.			H1									
ASME CL 300 / 4 in.			H2									
Mounting Flange Material - 9th character												
Carbon steel						C						
AISI 316 ss						S						
Extensions Length and Material - 10th character												
Flush							F					
50 mm (2 in.)	AISI 316 L ss	(Note 1)						1				
50 mm (2 in.)	Hastelloy C-276	(Note 1)						2				
100 mm (4 in.)	AISI 316 L ss	(Note 1)						3				
100 mm (4 in.)	Hastelloy C-276	(Note 1)						4				
150 mm (6 in.)	AISI 316 L ss	(Note 1)						5				
150 mm (6 in.)	Hastelloy C-276	(Note 1)						6				
Diaphragm Material - 11th and 12th characters												
AISI 316 L ss	(Note 2)		NACE					SM				
AISI 316 L ss - Low thickness (not for extended diaphragm)	(Note 3)		NACE					SL				
Hastelloy C-276			NACE					HM				
Hastelloy C-276 - Low thickness (not for extended diaphragm)	(Note 3)		NACE					HL				
Hastelloy C-2000 (not for extended diaphragm)	(Note 3)		NACE					MM				
Hastelloy C-2000 diaphragm and body (not for extended diaphragm)	(Note 3)		NACE					ZM				
Inconel 625 (not for extended diaphragm)	(Note 3)		NACE					LM				
Tantalum (not for extended diaphragm)	(Note 3)							TM				
AISI 316 L ss gold plated (not for extended diaphragm)	(Note 3)		NACE					NM				
AISI 316 L ss with PFA anti-stick coating	(Note 2)		NACE					KM				
Hastelloy C-276 with PFA anti-stick coating			NACE					YM				
AISI 316 L ss with PFA coating anti-corrosion and anti-stick	(Note 2)		NACE					WM				
Diaflex (AISI with anti-abrasion treatment)	(Note 2)		NACE					FM				
Superduplex ss (UNS S32750 to ASTM SA479) (not for extended diaphragm)	(Note 3)		NACE					EM				
Monel (not for extended diaphragm)	(Note 3)		NACE					GM				

continued
see next page

...Basic ordering information for model S26RA Rotating flange diaphragm seals (flush and extended) to ASME B16.5

		S 2 6 R A X X X X X X X X	X	X	X	X	X	X	X
Seal Surface Finish - 13th character									
Serrated	(Note 4)		1						
Smooth	(Note 15)		2						
Capillary Protection - 14th character									
AISI 316 L ss armour					A				
AISI 316 L ss armour with PVC protective cover					B				
Extension tube for direct mount seal	(Note 5)				N				
Capillary Length m (Feet) - 15th character									
Direct-mount construction	(Note 6)						1		
1 (3)	(Note 7)						A		
1.5 (5)	(Note 7)						B		
2 (7)	(Note 7)						C		
2.5 (8)	(Note 7)						D		
3 (10)	(Note 7)						E		
3.5 (12)	(Note 7)						F		
4 (13)	(Note 7)						G		
4.5 (15)	(Note 7)						H		
5 (17)	(Note 7)						J		
5.5 (18)	(Note 7)						K		
6 (20)	(Note 7)						L		
6.5 (22)	(Note 7)						M		
7 (23.5)	(Note 7)						N		
7.5 (25)	(Note 7)						P		
8 (27)	(Note 7)						Q		
9 (30)	(Note 7)						R		
10 (33)	(Note 7)						S		
12 (40)	(Note 7)						T		
14 (47)	(Note 7)						U		
16 (53)	(Note 7)						V		
Fill Fluid - 16th character									
Silicone oil PMX 200 10 cSt	(-40 to 250 °C; -40 to 480 °F)						S		
Silicone oil Baysilone PD5 5 cSt	(-85 to 250 °C; -121 to 480 °F)						P		
Inert oil - Galden G5	(Oxygen service)	(Note 8)					N		
Inert oil - Halocarbon 4.2	(Oxygen service)	(Note 8)					D		
Silicone oil for high temperature	(-10 to 375 °C; 14 to 707 °F)						G		
Silicone polymer Syltherm XLT	(-100 to 100 °C; -148 to 212 °F)						C		
Mineral oil Esso Marcol 152	(FDA approved)	(Note 9)					W		
Vegetable oil Neobee M-20	(FDA approved)	(Note 9)					A		
Glycerin-water 70%	(FDA approved)	(Note 9)					B		

continued
see next page

...Ordering Information

...Basic ordering information for model S26RA Rotating flange diaphragm seals (flush and extended) to ASME B16.5

S 2 6 R A X X X X X X X X X X		X	X	X
Flushing Ring: Hole and Thread - 17th character				
None (TO BE SELECTED FOR EXTENDED VERSIONS)		N		
1 hole - 1/2 in. NPT	(Note 3)	2		
2 holes - 1/2 in. NPT	(Note 3)	3		
1 hole - 1/4 in. NPT	(Note 3)	4		
2 holes - 1/4 in. NPT	(Note 3)	5		
Flushing Ring Material - 18th character				
None	(Note 10)		N	
AISI 316 L ss	(Note 11)	NACE		A
Hastelloy C-276	(Notes 11, 12)	NACE		H
Flushing Ring: Plug and Gasket - 19th character				
No plug - No gasket				N
No plug - garlock	(Note 11)			A
No plug - PTFE	(Note 11)			B
No plug - graphite	(Note 11)			C
AISI 316 L ss - no gasket	(Notes 11, 13)	NACE		D
AISI 316 L ss - garlock	(Notes 11, 13)	NACE		E
AISI 316 L ss - PTFE	(Notes 11, 13)	NACE		F
AISI 316 L ss - graphite	(Notes 11, 13)	NACE		G
Hastelloy C-276 - no gasket	(Notes 11, 14)	NACE		H
Hastelloy C-276 - garlock	(Notes 11, 14)	NACE		L
Hastelloy C-276 - PTFE	(Notes 11, 14)	NACE		M
Hastelloy C-276 - graphite	(Notes 11, 14)	NACE		P

- Note 1: Not available with mounting flange rating code E3, E5, G3, G4, G5
- Note 2: Not available with extensions length and material code 2, 4, 6
- Note 3: Not available with extensions length and material code 1, 2, 3, 4, 5, 6
- Note 4: Not available with diaphragm material code MM, LM, TM, NM, KM, YM, WM
- Note 5: Not available with transmitter side of connection code L
- Note 6: Not available with capillary protection code A, B
- Note 7: Not available with capillary protection code N
- Note 8: Suitable for oxygen service
- Note 9: Suitable for food application
- Note 10: Not available with Flushing ring: hole and thread code 2, 3, 4, 5
- Note 11: Not available with Flushing ring: hole and thread code N
- Note 12: Not available with Seal surface finish code 1
- Note 13: Not available with Hastelloy C-276 flushing ring material code H
- Note 14: Not available with AISI 316 L flushing ring material code A
- Note 15: Not available with diaphragm material code ZM

Basic ordering information for model S26RE Rotating flange diaphragm seals (flush and extended) to EN 1092-1

Select one character or set of characters from each category and specify complete catalog number.

BASE MODEL - 1st to 5th characters	S	2	6	R	E	X	XX	X	X	XX	X	X	X	X	X	
Rotating flange diaphragm seal (flush and extended) to EN 1092-1																
Transmitter Side of Connection - 6th character																
High pressure side						H										
Low pressure side						L										
Mounting Flange Rating / Size - 7th and 8th characters																
PN 16 - 40 / DN 50							N2									
PN 63 / DN 50							N3									
PN 100 / DN 50							N4									
PN 16 / DN 80							P1									
PN 40 / DN 80							P2									
PN 63 / DN 80							P3									
PN 100 / DN 80							P4									
PN 16 / DN 100							Q1									
PN 40 / DN 100							Q2									
Mounting Flange Material - 9th character																
Carbon steel															C	
AISI 316 ss															S	
Extensions Length and Material - 10th character																
Flush															F	
50 mm. (2 in.) AISI 316 L ss (Note 1)																1
50 mm. (2 in.) Hastelloy C-276 (Note 1)																2
100 mm. (4 in.) AISI 316 L ss (Note 1)																3
100 mm. (4 in.) Hastelloy C-276 (Note 1)																4
150 mm. (6 in.) AISI 316 L ss (Note 1)																5
150 mm. (6 in.) Hastelloy C-276 (Note 1)																6
Diaphragm Material - 11th and 12th characters																
AISI 316 L ss (Note 2)								NACE								SM
AISI 316 L ss - Low thickness (not for extended diaphragm) (Note 3)								NACE								SL
Hastelloy C-276 (Note 3)								NACE								HM
Hastelloy C-276 - Low thickness (not for extended diaphragm) (Note 3)								NACE								HL
Hastelloy C-2000 (not for extended diaphragm) (Note 3)								NACE								MM
Inconel 625 (not for extended diaphragm) (Note 3)								NACE								LM
Tantalum (not for extended diaphragm) (Note 3)																TM
AISI 316 L ss gold plated (not for extended diaphragm) (Note 3)								NACE								NM
AISI 316 L ss with PFA anti-stick coating (Note 2)								NACE								KM
Hastelloy C-276 with PFA anti-stick coating (Note 2)								NACE								YM
AISI 316 L ss with PFA coating anti-corrosion and anti-stick (Note 2)								NACE								WM
Diaflex (AISI with anti-abrasion treatment) (Note 2)								NACE								FM
Superduplex ss (UNS S32750 to ASTM SA479) (not for extended diaphragm) (Note 3)								NACE								EM
Monel (Note 3)								NACE								GM

continued
see next page

...Ordering Information

...Basic ordering information for model S26RE Rotating flange diaphragm seals (flush and extended) to EN 1092-1

		S 2 6 R E X X X X X X X X	X	X	X	X	X	X	X
Seal Surface Finish - 13th character									
Serrated	(Note 4)		1						
Smooth			2						
Capillary Protection - 14th character									
AISI 316 L ss armour							A		
AISI 316 L ss armour with PVC protective cover							B		
Extension tube for direct mount seal	(Note 5)						N		
Capillary Length m (Feet) - 15th character									
Direct-mount construction	(Note 6)						1		
1 (3)	(Note 7)						A		
1.5 (5)	(Note 7)						B		
2 (7)	(Note 7)						C		
2.5 (8)	(Note 7)						D		
3 (10)	(Note 7)						E		
3.5 (12)	(Note 7)						F		
4 (13)	(Note 7)						G		
4.5 (15)	(Note 7)						H		
5 (17)	(Note 7)						J		
5.5 (18)	(Note 7)						K		
6 (20)	(Note 7)						L		
6.5 (22)	(Note 7)						M		
7 (23.5)	(Note 7)						N		
7.5 (25)	(Note 7)						P		
8 (27)	(Note 7)						Q		
9 (30)	(Note 7)						R		
10 (33)	(Note 7)						S		
12 (40)	(Note 7)						T		
14 (47)	(Note 7)						U		
16 (53)	(Note 7)						V		
Fill Fluid - 16th character									
Silicone oil PMX 200 10 cSt	(-40 to 250 °C; -40 to 480 °F)						S		
Silicone oil Baysilone PD5 5 cSt	(-85 to 250 °C; -121 to 480 °F)						P		
Inert oil - Galden G5	(Oxygen service)	(Note 8)					N		
Inert oil - Halocarbon 4.2	(Oxygen service)	(Note 8)					D		
Silicone oil for high temperature	(-10 to 375 °C; 14 to 707 °F)						G		
Silicone polymer Syltherm XLT	(-100 to 100 °C; -148 to 212 °F)						C		
Mineral oil Esso Marcol 152	(FDA approved)	(Note 9)					W		
Vegetable oil Neobee M-20	(FDA approved)	(Note 9)					A		
Glycerin-water 70%	(FDA approved)	(Note 9)					B		

continued
see next page

..Basic ordering information for model S26RE Rotating flange diaphragm seals (flush and extended) to EN 1092-1

S 2 6 R E X X X X X X X X X X		X	X	X
Flushing Ring: Hole and Thread - 17th character				
None (TO BE SELECTED FOR EXTENDED VERSIONS)		N		
1 hole - 1/2 in. NPT	(Note 3)	2		
2 holes - 1/2 in. NPT	(Note 3)	3		
1 hole - 1/4 in. NPT	(Note 3)	4		
2 holes - 1/4 in. NPT	(Note 3)	5		
Flushing Ring Material - 18th character				
None	(Note 10)		N	
AISI 316 L ss	(Note 11) NACE		A	
Hastelloy C-276	(Notes 11, 12) NACE		H	
Flushing Ring: Plug and Gasket - 19th character				
No plug - No gasket				N
No plug - garlock	(Note 11)			A
No plug - PTFE	(Note 11)			B
No plug - graphite	(Note 11)			C
AISI 316 L ss - no gasket	(Notes 11, 13) NACE			D
AISI 316 L ss - garlock	(Notes 11, 13) NACE			E
AISI 316 L ss - PTFE	(Notes 11, 13) NACE			F
AISI 316 L ss - graphite	(Notes 11, 13) NACE			G
Hastelloy C-276 - no gasket	(Notes 11, 14) NACE			H
Hastelloy C-276 - garlock	(Notes 11, 14) NACE			L
Hastelloy C-276 - PTFE	(Notes 11, 14) NACE			M
Hastelloy C-276 - graphite	(Notes 11, 14) NACE			P

- Note 1: Not available with mounting flange rating code N3, N4, P3, P4
- Note 2: Not available with extensions length and material code 2, 4, 6
- Note 3: Not available with extensions length and material code 1, 2, 3, 4, 5, 6
- Note 4: Not available with diaphragm material code MM, LM, TM, NM, KM, YM, WM
- Note 5: Not available with transmitter side of connection code L
- Note 6: Not available with capillary protection code A, B
- Note 7: Not available with capillary protection code N
- Note 8: Suitable for oxygen service
- Note 9: Suitable for food application
- Note 10: Not available with Flushing ring: hole and thread code 2, 3, 4, 5
- Note 11: Not available with Flushing ring: hole and thread code N
- Note 12: Not available with Seal surface finish code 1
- Note 13: Not available with Hastelloy C-276 flushing ring material code H
- Note 14: Not available with AISI 316 L flushing ring material code A

...Ordering Information

Basic ordering information for model S26RJ Rotating flange diaphragm seals (flush) to JIS

Select one character or set of characters from each category and specify complete catalog number.

BASE MODEL - 1st to 5th characters	S	2	6	R	J	X	XX	X	X	XX	X	X	X	X	X	X	X
Rotating flange diaphragm seal (flush) to JIS																	
Transmitter Side of Connection - 6th character																	
High pressure side						H											
Low pressure side						L											
Mounting Flange Rating / Size - 7th and 8th characters																	
10K / A50							B2										
20K / A50							B4										
40K / A50							B6										
10K / A80							C2										
20K / A80							C4										
40K / A80							C6										
10K / A100							D2										
20K / A100							D4										
Mounting Flange Material - 9th character																	
Carbon steel								C									
AISI 316 ss								S									
Extensions Length - 10th character																	
Flush									F								
Diaphragm Material - 11th and 12th characters																	
AISI 316 L ss							NACE			SM							
Hastelloy C-276							NACE			HM							
Hastelloy C-2000							NACE			MM							
Inconel 625							NACE			LM							
Tantalum										TM							
AISI 316 L ss gold plated							NACE			NM							
AISI 316 L ss with PFA anti-stick coating							NACE			KM							
Hastelloy C-276 with PFA anti-stick coating							NACE			YM							
AISI 316 L ss with PFA coating anti-corrosion and anti-stick							NACE			WM							
Superduplex ss (UNS S32750 to ASTM SA479)							NACE			EM							
Seal Surface Finish - 13th character																	
Serrated (Note 1)																	1
Smooth																	2
Capillary Protection - 14th character																	
AISI 316 L ss armour																	A
AISI 316 L ss armour with PVC protective cover																	B
Extension tube for direct mount seal (Note 2)																	N

continued
see next page

...Basic ordering information for model S26RJ Rotating flange diaphragm seals (flush) to JIS

		S 2 6 R J X X X X X X X X	X	X	X	X	X
Capillary Length m (Feet) - 15th character							
Direct-mount construction	(Note 3)		1				
1 (3)	(Note 4)		A				
1.5 (5)	(Note 4)		B				
2 (7)	(Note 4)		C				
2.5 (8)	(Note 4)		D				
3 (10)	(Note 4)		E				
3.5 (12)	(Note 4)		F				
4 (13)	(Note 4)		G				
4.5 (15)	(Note 4)		H				
5 (17)	(Note 4)		J				
5.5 (18)	(Note 4)		K				
6 (20)	(Note 4)		L				
6.5 (22)	(Note 4)		M				
7 (23.5)	(Note 4)		N				
7.5 (25)	(Note 4)		P				
8 (27)	(Note 4)		Q				
9 (30)	(Note 4)		R				
10 (33)	(Note 4)		S				
12 (40)	(Note 4)		T				
14 (47)	(Note 4)		U				
16 (53)	(Note 4)		V				
Fill Fluid - 16th character							
Silicone oil PMX 200 10 cSt	(-40 to 250 °C; -40 to 480 °F)			S			
Silicone oil Baysilone PD5 5 cSt	(-85 to 250 °C; -121 to 480 °F)			P			
Inert oil - Galden G5	(Oxygen service)	(Note 5)		N			
Inert oil - Halocarbon 4.2	(Oxygen service)	(Note 5)		D			
Silicone oil for high temperature	(-10 to 375 °C; 14 to 707 °F)			G			
Silicone polymer Syltherm XLT	(-100 to 100 °C; -148 to 212 °F)			C			
Mineral oil Esso Marcol 152	(FDA approved)	(Note 6)		W			
Vegetable oil Neobee M-20	(FDA approved)	(Note 6)		A			
Glycerin-water 70%	(FDA approved)	(Note 6)		B			
Flushing Ring: Hole and Thread - 17th character							
None						N	
Flushing Ring Material - 18th character							
None							N
Flushing Ring: Plug and Gasket - 19th character							
None							N

Note 1: Not available with diaphragm material code HM, MM, LM, TN, NM, KM, YM, WM
 Note 2: Not available with transmitter side of connection code L
 Note 3: Not available with capillary protection code A, B
 Note 4: Not available with capillary protection code N
 Note 5: Suitable for oxygen service
 Note 6: Suitable for food application

...Ordering Information

Basic ordering information for model S26RR Rotating flange diaphragm seals (flush) Ring Joint to ASME B16.5

Select one character or set of characters from each category and specify complete catalog number.

BASE MODEL - 1st to 5th characters	S	2	6	R	R	X	XX	X	X	XX	X	X	X	X	X	X	X
Rotating flange diaphragm seal (flush) Ring Joint to ASME B16.5						X	XX	X	X	XX	X	X	X	X	X	X	X
Transmitter Side of Connection - 6th character																	
High pressure side						H											
Low pressure side						L											
Mounting Flange Rating / Size - 7th and 8th characters																	
ASME CL 150 / 1 1/2 in.																	D1
ASME CL 300 / 1 1/2 in.																	D2
ASME CL 600 / 1 1/2 in.																	D3
ASME CL 900-1500 / 1 1/2 in.																	D5
ASME CL 2500 / 1 1/2 in.																	D6
ASME CL 150 / 2 in.																	E1
ASME CL 300 / 2 in.																	E2
ASME CL 600 / 2 in.																	E3
ASME CL 900-1500 / 2 in.																	E5
ASME CL 2500 / 2 in.																	E6
ASME CL 150 / 3 in.																	G1
ASME CL 300 / 3 in.																	G2
ASME CL 600 / 3 in.																	G3
ASME CL 900 / 3 in.																	G4
ASME CL 1500 / 3 in.																	G5
ASME CL 2500 / 3 in. (NOT AVAILABLE FOR DIRECT MOUNT SEAL)																	G6
Mounting Flange Material - 9th character																	
Carbon steel																	C
AISI 316 ss																	S
Extensions Length - 10th character																	
Flush																	F
Diaphragm Material - 11th and 12th characters																	
AISI 316 L ss																	NACE SM
Hastelloy C-276																	NACE HM
Inconel 625																	NACE LM
Seal Surface Finish - 13th character																	
Ring joint																	3
Capillary Protection - 14th character																	
AISI 316 L ss armour																	A
AISI 316 L ss armour with PVC protective cover																	B
Extension tube for direct mount seal (Note 1)																	N

continued
see next page

...Basic ordering information for model S26RR Rotating flange diaphragm seals (flush) Ring Joint to ASME B16.5

		S 2 6 R R X X X X X X X X	X	X	X	X	X
Capillary Length m (Feet) - 15th character							
Direct-mount construction	(Note 2)		1				
1 (3)	(Note 3)		A				
1.5 (5)	(Note 3)		B				
2 (7)	(Note 3)		C				
2.5 (8)	(Note 3)		D				
3 (10)	(Note 3)		E				
3.5 (12)	(Note 3)		F				
4 (13)	(Note 3)		G				
4.5 (15)	(Note 3)		H				
5 (17)	(Note 3)		J				
5.5 (18)	(Note 3)		K				
6 (20)	(Note 3)		L				
6.5 (22)	(Note 3)		M				
7 (23.5)	(Note 3)		N				
7.5 (25)	(Note 3)		P				
8 (27)	(Note 3)		Q				
9 (30)	(Note 3)		R				
10 (33)	(Note 3)		S				
12 (40)	(Note 3)		T				
14 (47)	(Note 3)		U				
16 (53)	(Note 3)		V				
Fill Fluid - 16th character							
Silicone oil PMX 200 10 cSt	(-40 to 250 °C; -40 to 480 °F)			S			
Silicone oil Baysilone PD5 5 cSt	(-85 to 250 °C; -121 to 480 °F)			P			
Inert oil - Galden G5	(Oxygen service) (Note 4)			N			
Inert oil - Halocarbon 4.2	(Oxygen service) (Note 4)			D			
Silicone oil for high temperature	(-10 to 375 °C; 14 to 707 °F)			G			
Silicone polymer Syltherm XLT	(-100 to 100 °C; -148 to 212 °F)			C			
Mineral oil Esso Marcol 152	(FDA approved) (Note 5)			W			
Vegetable oil Neobee M-20	(FDA approved) (Note 5)			A			
Glycerin-water 70%	(FDA approved) (Note 5)			B			
Flushing Ring: Hole and Thread - 17th character							
None						N	
Flushing Ring Material - 18th character							
None							N
Flushing Ring: Plug and Gasket - 19th character							
None							N

Note 1: Not available with transmitter side of connection code L
 Note 2: Not available with capillary protection code A, B
 Note 3: Not available with capillary protection code N
 Note 4: Suitable for oxygen service
 Note 5: Suitable for food application

...Ordering Information

Basic ordering information for model S26RH Rotating flange diaphragm seals (flush) to ISO 10423 (API standards)

Select one character or set of characters from each category and specify complete catalog number.

BASE MODEL - 1st to 5th characters	S	2	6	R	H	X	XX	X	X	XX	X	X	X	X	X	X	X	X
Rotating flange diaphragm seal (flush) to ISO 10423																		
Transmitter Side of Connection - 6th character																		
High pressure side																		
Low pressure side																		
Size / Rating - 7th and 8th characters																		
ISO 10423 1 13/16 in. / API 10000 (69 MPa)																		
ISO 10423 1 13/16 in. / API 15000 (103.5 MPa)																		
ISO 10423 2 1/16 in. / API 10000 (69 MPa)																		
ISO 10423 2 1/16 in. / API 15000 (103.5 MPa)																		
Mounting Flange Material - 9th character																		
AISI 316 ss																		
Extensions Length - 10th character																		
Flush																		
Diaphragm Material - 11th and 12th characters																		
AISI 316 L ss																		
Hastelloy C-276																		
Inconel 625																		
Seal Surface Finish - 13th character																		
According to ISO 10423																		
Capillary Protection - 14th character																		
AISI 316 L ss armour																		
AISI 316 L ss armour with PVC protective cover																		
Extension tube for direct mount seal																		

continued
see next page

(Note 1)

...Basic ordering information for model S26RH Rotating flange diaphragm seals (flush) to ISO 10423 (API standards)

		S 2 6 R H X X X X X X X X	X	X	X	X	X
Capillary Length m (Feet) - 15th character							
Direct-mount construction		(Note 2)	1				
1 (3)		(Note 3)	A				
1.5 (5)		(Note 3)	B				
2 (7)		(Note 3)	C				
2.5 (8)		(Note 3)	D				
3 (10)		(Note 3)	E				
3.5 (12)		(Note 3)	F				
4 (13)		(Note 3)	G				
4.5 (15)		(Note 3)	H				
5 (17)		(Note 3)	J				
5.5 (18)	ONLY AVAILABLE FOR SIZE 2 1/16 in (code S1, S2)	(Note 3)	K				
6 (20)	ONLY AVAILABLE FOR SIZE 2 1/16 in (code S1, S2)	(Note 3)	L				
6.5 (22)	ONLY AVAILABLE FOR SIZE 2 1/16 in (code S1, S2)	(Note 3)	M				
7 (23.5)	ONLY AVAILABLE FOR SIZE 2 1/16 in (code S1, S2)	(Note 3)	N				
7.5 (25)	ONLY AVAILABLE FOR SIZE 2 1/16 in (code S1, S2)	(Note 3)	P				
8 (27)	ONLY AVAILABLE FOR SIZE 2 1/16 in (code S1, S2)	(Note 3)	Q				
Fill Fluid - 16th character							
Silicone oil PMX 200 10 cSt	(-40 to 250 °C; -40 to 480 °F)			S			
Silicone oil Baysilone PD5 5 cSt	(-85 to 250 °C; -121 to 480 °F)			P			
Inert oil - Galden G5	(Oxygen service)	(Note 4)		N			
Inert oil - Halocarbon 4.2	(Oxygen service)	(Note 4)		D			
Silicone oil for high temperature	(-10 to 375 °C; 14 to 707 °F)			G			
Silicone polymer Syltherm XLT	(-100 to 100 °C; -148 to 212 °F)			C			
Flushing Ring: Hole and Thread - 17th character							
None						N	
Flushing Ring Material - 18th character							
None							N
Flushing Ring: Plug and Gasket - 19th character							
None							N

...Ordering Information

Basic ordering information for model S26FA Fixed flange diaphragm seals (flush and extended) to ASME B16.5

Select one character or set of characters from each category and specify complete catalog number.

BASE MODEL - 1st to 5th characters	S	2	6	F	A	X	XX	X	X	XX	X	X	X	X	X
Fixed flange diaphragm seal (flush) to ASME B16.5						X									
Transmitter Side of Connection - 6th character															
High pressure side						H									
Low pressure side						L									
Mounting Flange Rating / Size - 7th and 8th characters															
ASME CL 150 / 2 in.							E1								
ASME CL 300 / 2 in.							E2								
ASME CL 600 / 2 in.							E3								
ASME CL 150 / 3 in.							G1								
ASME CL 300 / 3 in.							G2								
ASME CL 600 / 3 in.							G3								
ASME CL 150 / 4 in.							H1								
Mounting Flange Material - 9th character															
AISI 316 L ss								S							
Extensions Length and Material - 10th character															
Flush										F					
50 mm. (2 in.)					AISI 316 L ss					1					
100 mm. (4 in.)					AISI 316 L ss					3					
150 mm. (6 in.)					AISI 316 L ss					5					
Diaphragm Material - 11th and 12th characters															
AISI 316 L ss								NACE			SM				
AISI 316 L ss - Low thickness					(Note 1)			NACE			SL				
Hastelloy C-276								NACE			HM				
Hastelloy C-276 - Low thickness					(Note 1)			NACE			HL				
Hastelloy C-2000					(Note 1)			NACE			MM				
Inconel 625					(Note 1)			NACE			LM				

continued
see next page

...Basic ordering information for model S26FA Fixed flange diaphragm seals (flush and extended) to ASME B16.5

		S 2 6 F A X X X X X X X	X	X	X	X	X	X	X
Seal Surface Finish - 13th character									
Serrated	(Note 2)		1						
Smooth			2						
Capillary Protection - 14th character									
AISI 316 L ss armour							A		
AISI 316 L ss armour with PVC protective cover							B		
Extension tube for direct mount seal	(Note 3)						N		
Capillary Length m (Feet) - 15th character									
Direct-mount construction	(Note 4)						1		
1 (3)	(Note 5)						A		
1.5 (5)	(Note 5)						B		
2 (7)	(Note 5)						C		
2.5 (8)	(Note 5)						D		
3 (10)	(Note 5)						E		
3.5 (12)	(Note 5)						F		
4 (13)	(Note 5)						G		
4.5 (15)	(Note 5)						H		
5 (17)	(Note 5)						J		
5.5 (18)	(Note 5)						K		
6 (20)	(Note 5)						L		
6.5 (22)	(Note 5)						M		
7 (23.5)	(Note 5)						N		
7.5 (25)	(Note 5)						P		
8 (27)	(Note 5)						Q		
9 (30)	(Note 5)						R		
10 (33)	(Note 5)						S		
12 (40)	(Note 5)						T		
14 (47)	(Notes1, 5)						U		
16 (53)	(Notes1, 5)						V		
Fill Fluid - 16th character									
Silicone oil PMX 200 10 cSt	(-40 to 250 °C; -40 to 480 °F)						S		
Silicone oil Baysilone PD5 5 cSt	(-85 to 250 °C; -121 to 480 °F)						P		
Inert oil - Galden G5	(Oxygen service)	(Note 6)					N		
Inert oil - Halocarbon 4.2	(Oxygen service)	(Note 6)					D		
Silicone oil for high temperature	(-10 to 375 °C; 14 to 707 °F)						G		
Silicone polymer Syltherm XLT	(-100 to 100 °C; -148 to 212 °F)						C		
Mineral oil Esso Marcol 152	(FDA approved)	(Note 7)					W		
Vegetable oil Neobee M-20	(FDA approved)	(Note 7)					A		
Glycerin-water 70%	(FDA approved)	(Note 7)					B		

continued
see next page

...Ordering Information

...Basic ordering information for model S26FA Fixed flange diaphragm seals (flush and extended) to ASME B16.5

S 2 6 F A X X X X X X X X X X		X	X	X
Flushing Ring: Hole and Thread - 17th character				
None		N		
1 hole - 1/2 in. NPT	(Note 1)	2		
2 holes - 1/2 in. NPT	(Note 1)	3		
1 hole - 1/4 in. NPT	(Note 1)	4		
2 holes - 1/4 in. NPT	(Note 1)	5		
Flushing Ring Material - 18th character				
None	(Note 8)		N	
AISI 316 L ss	(Note 9)	NACE		A
Hastelloy C-276	(Notes 9, 10)	NACE		H
Flushing Ring: Plug and Gasket - 19th character				
No plug - No gasket				N
No plug - garlock	(Note 9)			A
No plug - PTFE	(Note 9)			B
No plug - graphite	(Note 9)			C
AISI 316 L ss - no gasket	(Notes 9, 11)	NACE		D
AISI 316 L ss - garlock	(Notes 9, 11)	NACE		E
AISI 316 L ss - PTFE	(Notes 9, 11)	NACE		F
AISI 316 L ss - graphite	(Notes 9, 11)	NACE		G
Hastelloy C-276 - no gasket	(Notes 9, 12)	NACE		H
Hastelloy C-276 - garlock	(Notes 9, 12)	NACE		L
Hastelloy C-276 - PTFE	(Notes 9, 12)	NACE		M
Hastelloy C-276 - graphite	(Notes 9, 12)	NACE		P

- Note 1: Not available with extensions length and material code 1, 3, 5
- Note 2: Not available with diaphragm material code MM, LM
- Note 3: Not available with transmitter side of connection code L
- Note 4: Not available with capillary protection code A, B
- Note 5: Not available with capillary protection code N
- Note 6: Suitable for oxygen service
- Note 7: Suitable for food application
- Note 8: Not available with Flushing ring: hole and thread code 2, 3, 4, 5
- Note 9: Not available with Flushing ring: hole and thread code N
- Note 10: Not available with Seal surface finish code 1
- Note 11: Not available with Hastelloy C-276 flushing ring material code H
- Note 12: Not available with AISI 316 L flushing ring material code A

Basic ordering information for model S26FE Fixed flange diaphragm seals (flush and extended) to EN 1092-1

Select one character or set of characters from each category and specify complete catalog number.

BASE MODEL - 1st to 5th characters		S	2	6	F	E	X	XX	X	X	XX	X	X	X	X	X
Fixed flange diaphragm seal (flush) to EN 1092-1																
Transmitter Side of Connection - 6th character																
High pressure side							H									
Low pressure side							L									
Mounting Flange Rating / Size - 7th and 8th characters																
PN 16 / DN 50								N1								
PN 40 / DN 50								N2								
PN 63 / DN 50					(Note 1)			N3								
PN 100 / DN 50					(Note 1)			N4								
PN 16 / DN 80								P1								
PN 40 / DN 80								P2								
PN 63 / DN 80					(Note 1)			P3								
PN 100 / DN 80					(Note 1)			P4								
PN 16 / DN 100								Q1								
Mounting Flange Material - 9th character																
AISI 316 L ss									S							
Extensions Length - 10th character																
Flush											F					
50 mm. (2 in.)					AISI 316 L ss							1				
100 mm. (4 in.)					AISI 316 L ss								3			
150 mm. (6 in.)					AISI 316 L ss									5		
Diaphragm Material - 11th and 12th characters																
AISI 316 L ss								NACE								SM
AISI 316 L ss - Low thickness (not for extended diaphragm)					(Note 1)			NACE								SL
Hastelloy C-276								NACE								HM
Hastelloy C-276 - Low thickness (not for extended diaphragm)					(Note 1)			NACE								HL
Hastelloy C-2000 (not for extended diaphragm)					(Note 1)			NACE								MM
Inconel 625 (not for extended diaphragm)					(Note 1)			NACE								LM

continued
see next page

...Ordering Information

...Basic ordering information for model S26FE Fixed flange diaphragm seals (flush and extended) to EN 1092-1

		S 2 6 F E X X X X X X X X	X	X	X	X	X	X	X
Seal Surface Finish - 13th character									
Serrated	(Note 2)		1						
Smooth			2						
Form E - Spigot type	(Notes 1, 3)		4						
Form D - Groove type	(Notes 1, 3, 4)		6						
Capillary Protection - 14th character									
AISI 316 L ss armour							A		
AISI 316 L ss armour with PVC protective cover							B		
Extension tube for direct mount seal	(Note 5)						N		
Capillary Length m (Feet) - 15th character									
Direct-mount construction	(Note 6)						1		
1 (3)	(Note 7)						A		
1.5 (5)	(Note 7)						B		
2 (7)	(Note 7)						C		
2.5 (8)	(Note 7)						D		
3 (10)	(Note 7)						E		
3.5 (12)	(Note 7)						F		
4 (13)	(Note 7)						G		
4.5 (15)	(Note 7)						H		
5 (17)	(Note 7)						J		
5.5 (18)	(Note 7)						K		
6 (20)	(Note 7)						L		
6.5 (22)	(Note 7)						M		
7 (23.5)	(Note 7)						N		
7.5 (25)	(Note 7)						P		
8 (27)	(Note 7)						Q		
9 (30)	(Note 7)						R		
10 (33)	(Note 7)						S		
12 (40)	(Note 7)						T		
14 (47)	(Notes 1, 7)						U		
16 (53)	(Notes 1, 7)						V		
Fill Fluid - 16th character									
Silicone oil PMX 200 10 cSt	(-40 to 250 °C; -40 to 480 °F)						S		
Silicone oil Baysilone PD5 5 cSt	(-85 to 250 °C; -121 to 480 °F)						P		
Inert oil - Galden G5	(Oxygen service)	(Note 8)					N		
Inert oil - Halocarbon 4.2	(Oxygen service)	(Note 8)					D		
Silicone oil for high temperature	(-10 to 375 °C; 14 to 707 °F)						G		
Silicone polymer Syltherm XLT	(-100 to 100 °C; -148 to 212 °F)						C		
Mineral oil Esso Marcol 152	(FDA approved)	(Note 9)					W		
Vegetable oil Neobee M-20	(FDA approved)	(Note 9)					A		
Glycerin-water 70%	(FDA approved)	(Note 9)					B		

continued
see next page

...Basic ordering information for model S26FE Fixed flange diaphragm seals (flush and extended) to EN 1092-1

S 2 6 F E X X X X X X X X X X X X X X		X	X	X
Flushing Ring: Hole and Thread - 17th character				
None		N		
1 hole - 1/2 in. NPT	(Notes 1, 10)	2		
2 holes - 1/2 in. NPT	(Notes 1, 10)	3		
1 hole - 1/4 in. NPT	(Notes 1, 10)	4		
2 holes - 1/4 in. NPT	(Notes 1, 10)	5		
Flushing Ring Material - 18th character				
None	(Note 11)		N	
AISI 316 L ss	(Note 12) NACE		A	
Hastelloy C-276	(Notes 12, 13) NACE		H	
Flushing Ring: Plug and Gasket - 19th character				
No plug - No gasket				N
No plug - garlock	(Note 12)			A
No plug - PTFE	(Note 12)			B
No plug - graphite	(Note 12)			C
AISI 316 L ss - no gasket	(Notes 12, 14) NACE			D
AISI 316 L ss - garlock	(Notes 12, 14) NACE			E
AISI 316 L ss - PTFE	(Notes 12, 14) NACE			F
AISI 316 L ss - graphite	(Notes 12, 14) NACE			G
Hastelloy C-276 - no gasket	(Notes 12, 15) NACE			H
Hastelloy C-276 - garlock	(Notes 12, 15) NACE			L
Hastelloy C-276 - PTFE	(Notes 12, 15) NACE			M
Hastelloy C-276 - graphite	(Notes 12, 15) NACE			P

- Note 1: Not available with extensions length and material code 1, 3, 5
- Note 2: Not available with diaphragm material code MM, LM
- Note 3: Not available with DN 100 size code Q1
- Note 4: Not available with diaphragm material code HM, HL, MM, LM
- Note 5: Not available with transmitter side of connection code L
- Note 6: Not available with capillary protection code A, B
- Note 7: Not available with capillary protection code N
- Note 8: Suitable for oxygen service
- Note 9: Suitable for food application
- Note 10: Not available with Seal surface finish code 4, 6
- Note 11: Not available with Flushing ring: hole and thread code 2, 3, 4, 5
- Note 12: Not available with Flushing ring: hole and thread code N
- Note 13: Not available with Seal surface finish code 1
- Note 14: Not available with Hastelloy C-276 flushing ring material code H
- Note 15: Not available with AISI 316 L flushing ring material code A

...Ordering Information

Basic ordering information for model S26MA Off-line flange diaphragm seal to ASME B16.5

Select one character or set of characters from each category and specify complete catalog number.

BASE MODEL - 1st to 5th characters	S 2 6 M A		X	XX	X	XX	X	X	X	X	X
Off-line flange diaphragm seal to ASME B16.5											
Transmitter Side of Connection - 6th character											
High pressure side			H								
Low pressure side			L								
Mounting Flange Rating / Size - 7th and 8th characters											
ASME CL 150 / 1/2 in.				A1							
ASME CL 300 / 1/2 in.				A2							
ASME CL 150 / 1 in.				C1							
ASME CL 300 / 1 in.				C2							
ASME CL 150 / 1 1/2 in.				D1							
ASME CL 300 / 1 1/2 in.				D2							
Mounting Flange Material / Seat Form - 9th character											
AISI 316 L ss / Form RF (raised face) - serrated finish	NACE	(Note 6)			S						
Hastelloy C-276 / Form RF (raised face) - serrated finish	NACE	(Note 6)			H						
Hastelloy C-2000 / Form RF (raised face) - serrated finish	NACE	(Note 7)			Y						
Diaphragm Material - 10th and 11th characters											
AISI 316 L ss	NACE				SM						
Hastelloy C-276	NACE				HM						
Hastelloy C-2000	NACE				MM						
Hastelloy C-2000 diaphragm and body	NACE				ZM						
Inconel 625	NACE				LM						
Tantalum					TM						
AISI 316 L ss gold plated	NACE				NM						
Capillary Protection - 12th character											
AISI 316 L ss armour								A			
AISI 316 L ss armour with PVC protective cover								B			
Extension tube for direct mount seal		(Note 1)						N			

continued
see next page

...Basic ordering information for model S26MA Off-line flange diaphragm seal to ASME B16.5

S 2 6 M A X X X X X X X		X	X	X	X
Capillary Length m (Feet) - 13th character					
Direct-mount construction	(Note 2)	1			
1 (3)	(Note 3)	A			
1.5 (5)	(Note 3)	B			
2 (7)	(Note 3)	C			
2.5 (8)	(Note 3)	D			
3 (10)	(Note 3)	E			
3.5 (12)	(Note 3)	F			
4 (13)	(Note 3)	G			
4.5 (15)	(Note 3)	H			
5 (17)	(Note 3)	J			
5.5 (18)	(Note 3)	K			
6 (20)	(Note 3)	L			
6.5 (22)	(Note 3)	M			
7 (23.5)	(Note 3)	N			
7.5 (25)	(Note 3)	P			
8 (27)	(Note 3)	Q			
9 (30)	(Note 3)	R			
10 (33)	(Note 3)	S			
12 (40)	(Note 3)	T			
Fill Fluid - 14th character					
Silicone oil PMX 200 10 cSt	(-40 to 250 °C; -40 to 480 °F)		S		
Silicone oil Baysilone PD5 5 cSt	(-85 to 250 °C; -121 to 480 °F)		P		
Inert oil - Galden G5	(Oxygen service)	(Note 4)		N	
Inert oil - Halocarbon 4.2	(Oxygen service)	(Note 4)		D	
Silicone oil for high temperature	(-10 to 375 °C; 14 to 707 °F)			G	
Silicone polymer Syltherm XLT	(-100 to 100 °C; -148 to 212 °F)			C	
Mineral oil Esso Marcol 152	(FDA approved)	(Note 5)		W	
Vegetable oil Neobee M-20	(FDA approved)	(Note 5)		A	
Glycerin-water 70%	(FDA approved)	(Note 5)		B	
Flushing Connections - 15th character					
Not required					1
Provided (with 2 plugs supplied)					Q
Gasket - 16th character					
PTFE					2
Viton®	(Note 6)				3
Graphite	(Note 6)				7

Note 1: Not available with transmitter side of connection code L

Note 2: Not available with capillary protection code A, B

Note 3: Not available with capillary protection code N

Note 4: Suitable for oxygen service

Note 5: Suitable for food application

Note 6: Not available with diaphragm material code ZM

Note 7: Not available with diaphragm material code SM, HM, MM, LM, TM, NM

...Ordering Information

Basic ordering information for model S26ME Off-line flange diaphragm seal to EN 1092-1

Select one character or set of characters from each category and specify complete catalog number.

BASE MODEL - 1st to 5th characters	S	2	6	M	E	X	XX	X	XX	X	X	X	X	X
Off-line flange diaphragm seal to EN 1092-1														
Transmitter Side of Connection - 6th character														
High pressure side						H								
Low pressure side						L								
Mounting Flange Rating / Size - 7th and 8th characters														
PN 16 - 40 / DN 25							L2							
PN 16 - 40 / DN 40							M2							
Mounting Flange Material / Seat Form - 9th character														
AISI 316 L ss / Form B1 - serrated finish				NACE				S						
Hastelloy C-276 / Form B1 - serrated finish				NACE				H						
Diaphragm Material - 10th and 11th characters														
AISI 316 L ss				NACE					SM					
Hastelloy C-276				NACE					HM					
Hastelloy C-2000				NACE					MM					
Inconel 625				NACE					LM					
Tantalum									TM					
AISI 316 L ss gold plated				NACE					NM					
Capillary Protection - 12th character														
AISI 316 L ss armour													A	
AISI 316 L ss armour with PVC protective cover													B	
Extension tube for direct mount seal (Note 1)													N	

continued
see next page

...Basic ordering information for model S26ME Off-line flange diaphragm seal to EN 1092-1

S 2 6 M E X X X X X X X		X	X	X	X
Capillary Length m (Feet) - 13th character					
Direct-mount construction	(Note 2)	1			
1 (3)	(Note 3)	A			
1.5 (5)	(Note 3)	B			
2 (7)	(Note 3)	C			
2.5 (8)	(Note 3)	D			
3 (10)	(Note 3)	E			
3.5 (12)	(Note 3)	F			
4 (13)	(Note 3)	G			
4.5 (15)	(Note 3)	H			
5 (17)	(Note 3)	J			
5.5 (18)	(Note 3)	K			
6 (20)	(Note 3)	L			
6.5 (22)	(Note 3)	M			
7 (23.5)	(Note 3)	N			
7.5 (25)	(Note 3)	P			
8 (27)	(Note 3)	Q			
9 (30)	(Note 3)	R			
10 (33)	(Note 3)	S			
12 (40)	(Note 3)	T			
Fill Fluid - 14th character					
Silicone oil PMX 200 10 cSt	(-40 to 250 °C; -40 to 480 °F)		S		
Silicone oil Baysilone PD5 5 cSt	(-85 to 250 °C; -121 to 480 °F)		P		
Inert oil - Galden G5	(Oxygen service)	(Note 4)		N	
Inert oil - Halocarbon 4.2	(Oxygen service)	(Note 4)		D	
Silicone oil for high temperature	(-10 to 375 °C; 14 to 707 °F)			G	
Silicone polymer Syltherm XLT	(-100 to 100 °C; -148 to 212 °F)			C	
Mineral oil Esso Marcol 152	(FDA approved)	(Note 5)		W	
Vegetable oil Neobee M-20	(FDA approved)	(Note 5)		A	
Glycerin-water 70%	(FDA approved)	(Note 5)		B	
Flushing Connections - 15th character					
Not required					1
Provided (with 2 plugs supplied)					Q
Gasket - 16th character					
PTFE					2
Viton®					3
Graphite					7

Note 1: Not available with transmitter side of connection code L
 Note 2: Not available with capillary protection code A, B
 Note 3: Not available with capillary protection code N
 Note 4: Suitable for oxygen service
 Note 5: Suitable for food application

...Ordering Information

Basic ordering information for model S26TT Off-line threaded diaphragm seal

Select one character or set of characters from each category and specify complete catalog number.

BASE MODEL - 1st to 5th characters	S 2 6 T T	X	X	X	X	XX	X	X	X	X	X	X
Off-line threaded diaphragm seal												
Transmitter Side of Connection - 6th character												
High pressure side		H										
Low pressure side		L										
Size - 7th character												
1/4 in. NPT-f												
1/2 in. NPT-f												
3/4 in. NPT-f												
1 in. NPT-f												
1 1/2 in. NPT-f												
Bolts material - 8th character												
AISI 316 ss												
Carbon steel												
Alloy steel												
Mounting Flange Material - 9th character												
AISI 316 L ss												
Hastelloy C-276												
Diaphragm Material - 10th and 11th characters												
AISI 316 L ss												
Hastelloy C-276												
Hastelloy C-2000												
Inconel 625												
Tantalum												
AISI 316 L ss gold plated												
Capillary Protection - 12th character												
AISI 316 L ss armour												
AISI 316 L ss armour with PVC protective cover												
Extension tube for direct mount seal												

continued
see next page

...Basic ordering information for model S26TT Off-line threaded diaphragm seal

		S	2	T	T	X	X	X	X
Capillary Length m (Feet) - 13th character							X	X	X
Direct-mount construction	(Note 2)						1		
1 (3)	(Note 3)						A		
1.5 (5)	(Note 3)						B		
2 (7)	(Note 3)						C		
2.5 (8)	(Note 3)						D		
3 (10)	(Note 3)						E		
3.5 (12)	(Note 3)						F		
4 (13)	(Note 3)						G		
4.5 (15)	(Note 3)						H		
5 (17)	(Note 3)						J		
5.5 (18)	(Note 3)						K		
6 (20)	(Note 3)						L		
6.5 (22)	(Note 3)						M		
7 (23.5)	(Note 3)						N		
7.5 (25)	(Note 3)						P		
8 (27)	(Note 3)						Q		
9 (30)	(Note 3)						R		
10 (33)	(Note 3)						S		
12 (40)	(Note 3)						T		
Fill Fluid - 14th character									
Silicone oil PMX 200 10 cSt	(-40 to 250 °C; -40 to 480 °F)							S	
Silicone oil Baysilone PD5 5 cSt	(-85 to 250 °C; -121 to 480 °F)							P	
Inert oil - Galden G5	(Oxygen service)	(Note 4)						N	
Inert oil - Halocarbon 4.2	(Oxygen service)	(Note 4)						D	
Silicone oil for high temperature	(-10 to 375 °C; 14 to 707 °F)							G	
Silicone polymer Syltherm XLT	(-100 to 100 °C; -148 to 212 °F)							C	
Mineral oil Esso Marcol 152	(FDA approved)	(Note 5)						W	
Vegetable oil Neobee M-20	(FDA approved)	(Note 5)						A	
Glycerin-water 70%	(FDA approved)	(Note 5)						B	
Flushing Connections - 15th character									
Not required									1
Provided (with 2 plugs supplied)	(Note 6)								Q
Gasket - 16th character									
PTFE									2
Viton®									3
Graphite									7

Note 1: Not available with transmitter side of connection code L
 Note 2: Not available with capillary protection code A, B
 Note 3: Not available with capillary protection code N
 Note 4: Suitable for oxygen service
 Note 5: Suitable for food application
 Note 6: Not available with size code 5

...Ordering Information

Basic ordering information for model S26SS Sanitary and food diaphragm seal

Select one character or set of characters from each category and specify complete catalog number.

BASE MODEL - 1st to 5th characters		S	2	6	S	S	X	X	XX	X	X	X	X	X
Sanitary and food diaphragm seal														
Transmitter Side of Connection - 6th character														
High pressure side							H							
Low pressure side							L							
Mounting connection - 7th character														
Union nut DIN 11851 – F50 (not 3-A authorized)														
Union nut DIN 11851 – F80 (not 3-A authorized)														
2 in. Triclamp														
3 in. Triclamp														
4 in. Triclamp														
2 in. Cherry Burrell														
3 in. Cherry Burrell														
4 in. Cherry Burrell														
4 in. Sanitary flush diaphragm														
4 in. Sanitary extended (2 in.) diaphragm														
4 in. Sanitary extended (4 in.) diaphragm														
4 in. Sanitary extended (6 in.) diaphragm														
4in Cherry Burrell aseptic - ONLY REMOTE MOUNT														
4in aseptic flanged connection - ONLY REMOTE MOUNT														
Beverage application bolted seal (not 3-A authorized) - ONLY DIRECT MOUNT WITH 266HRH, 266NRH														
Diaphragm Material - 8th and 9th characters														
AISI 316 L ss														
Capillary Protection - 10th character														
AISI 316 L ss armour	(Note 1)													A
AISI 316 L ss armour with PVC protective cover	(Note 1)													B
Extension tube for direct mount seal	(Note 2)													N
Capillary Length m (Feet) - 11th character														
Direct-mount construction	(Note 3)													1
1 (3)	(Note 4)													A
1.5 (5)	(Note 4)													B
2 (7)	(Note 4)													C
2.5 (8)	(Note 4)													D
3 (10)	(Note 4)													E
3.5 (12)	(Note 4)													F
4 (13)	(Note 4)													G
4.5 (15)	(Note 4)													H
5 (17)	(Note 4)													J
5.5 (18)	(Note 4)													K
6 (20)	(Note 4)													L
6.5 (22)	(Note 4)													M
7 (23.5)	(Note 4)													N
7.5 (25)	(Note 4)													P
8 (27)	(Note 4)													Q
9 (30)	(Note 4)													R
10 (33)	(Note 4)													S

continued
see next page

...Basic ordering information for model S26SS Sanitary and food diaphragm seal

S 2 6 S S X X X X X X			X	X	X
Fill Fluid - 12th character					
Silicone oil PMX 200 10 cSt	(-40 to 250 °C; -40 to 480 °F)		S		
Inert oil - Halocarbon 4.2	(-40 to 250 °C; -40 to 480 °F)	(Note 5)	D		
Silicone polymer Syltherm XLT	(-100 to 100 °C; -148 to 212 °F)		C		
Mineral oil Esso Marcol 152	(FDA approved)	(Note 6)	W		
Vegetable oil Neobee M-20	(FDA approved)	(Note 6)	A		
Glycerin-water 70%	(FDA approved)	(Note 6)	B		
Clamp/Fittings - 13th character					
None				1	
2 in. V-band Clamp (for 2 in. Triclamp)				A	
3 in. V-band Clamp (for 3 in. Triclamp)				B	
4 in. V-band Clamp (for 4 in. Triclamp, 4 in. Cherry Burrell, 4 in. Sanitary flush and 4 in. aseptic flanged)				C	
4 in. Tank spud, tank wall up to 4.7mm (0.18) and 4 in. V-band Clamp (for 4 in. Sanitary flush seal)				D	
4 in. Tank spud, tank wall up to 9.5mm (0.37) and 4 in. V-band Clamp (for 4 in. Sanitary flush seal)				E	
4 in. schedule 5 V-band clamp (for 4 in. Sanitary extended seal)				F	
Tank spud for 2 in. extension and 4 in. schedule 5 V-band clamp (for 4 in. Sanitary extended 2 in. seal)				G	
Tank spud for 4 in. extension and 4 in. schedule 5 V-band clamp (for 4 in. Sanitary extended 4 in. seal)				H	
Tank spud for 6 in. extension and 4 in. schedule 5 V-band clamp (for 4 in. Sanitary extended 6 in. seal)				J	
Aseptic tank spud (for 4 in. aseptic flanged seal)				P	
Flanged tank spud with 6 holes (for 1 1/2 in. beverage seal)				K	
Gasket - 14th character					
None					1
Ethylene propylene gasket DN100 (for 4 in. Sanitary extended seal) - (EPDM 3-A 18-03 Class II)					A
Ethylene propylene gasket (for 1 1/2 in. beverage seal)					B
Ethylene propylene gasket DN50 (for F50 Union nut seal)					C
Ethylene propylene gasket DN80 (for F80 Union nut seal)					D
Ethylene propylene gasket (for 4 in. Sanitary flush and 4 in. aseptic) - (EPDM 3-A 18-03 Class II)					G

- Note 1: Not available with beverage bolted seal connection code T
- Note 2: Not available with transmitter side of connection code L
- Note 3: Not available with capillary protection code A, B
- Note 4: Not available with capillary protection code N
- Note 5: Suitable for oxygen service
- Note 6: Suitable for food application

...Ordering Information

Basic ordering information for model S26VN Socket and saddle diaphragm seal

Select one character or set of characters from each category and specify complete catalog number.

BASE MODEL - 1st to 5th characters	S 2 6 V N	X	XX	X	X	X	X	X
Socket and saddle diaphragm seal								
Transmitter Side of Connection - 6th character								
High pressure side		H						
Low pressure side		L						
Diaphragm Material - 7th and 8th characters								
AISI 316 L ss	NACE		SM					
Hastelloy C-276	NACE		HM					
Hastelloy C-2000	NACE		MM					
Inconel 625	NACE		LM					
Tantalum			TM					
AISI 316 L ss gold plated	NACE		NM					
Superduplex ss (UNS S32750 to ASTM SA479)	NACE		EM					
Capillary Protection - 9th character								
AISI 316 L ss armour							A	
AISI 316 L ss armour with PVC protective cover							B	
Extension tube for direct mount seal	(Note 1)						N	

continued
see next page

...Basic ordering information for model S26VN Socket and saddle diaphragm seal

S 2 6 V N X X X X		X	X	X	X
Capillary Length m (Feet) - 10th character					
Direct-mount construction	(Note 2)	1			
1 (3)	(Note 3)	A			
1.5 (5)	(Note 3)	B			
2 (7)	(Note 3)	C			
2.5 (8)	(Note 3)	D			
3 (10)	(Note 3)	E			
3.5 (12)	(Note 3)	F			
4 (13)	(Note 3)	G			
4.5 (15)	(Note 3)	H			
5 (17)	(Note 3)	J			
Fill Fluid - 11th character					
Silicone oil PMX 200 10 cSt	(-40 to 250 °C; -40 to 480 °F)			S	
Silicone oil Baysilone PD5 5 cSt	(-85 to 250 °C; -121 to 480 °F)			P	
Inert oil - Galden G5	(Oxygen service)	(Note 4)		N	
Inert oil - Halocarbon 4.2	(Oxygen service)	(Note 4)		D	
Silicone oil for high temperature	(-10 to 375 °C; 14 to 707 °F)			G	
Silicone polymer Syltherm XLT	(-100 to 100 °C; -148 to 212 °F)			C	
Mineral oil Esso Marcol 152	(FDA approved)	(Note 5)		W	
Vegetable oil Neobee M-20	(FDA approved)	(Note 5)		A	
Glycerin-water 70%	(FDA approved)	(Note 5)		B	
Process Fitting Connections - 12th character					
Not required					N
Saddle 2 in.					1
Saddle 2 1/2 in.					2
Saddle 3 in.					3
Saddle 4 in.					4
Saddle 5 in.					5
Saddle 6 in.					6
Socket 1/2 in.					A
Socket 3/4 in.					B
Socket 1 in.					C
Socket 1 1/2 in.					D
Socket 2 in.					E
Gasket - 13th character					
PTFE					2
Graphite					7

Note 1: Not available with transmitter side of connection code L
 Note 2: Not available with capillary protection code A, B
 Note 3: Not available with capillary protection code N
 Note 4: Suitable for oxygen service
 Note 5: Suitable for food application

...Ordering Information

Basic ordering information for model S26WA Wafer diaphragm seal to ASME B16.5

Select one character or set of characters from each category and specify complete catalog number.

BASE MODEL - 1st to 5th characters	S 2 6 W A	X	XX	X	XX	X	X	X	X	X
Wafer diaphragm seal to ASME B16.5										
Transmitter Side of Connection - 6th character										
High pressure side		H								
Low pressure side		L								
Mounting Flange Rating / Size - 7th and 8th characters										
ASME 1 1/2 in.			D5							
ASME 2 in.			E5							
ASME 3 in.			G5							
Extensions Length and Material - 9th character										
Flush					F					
Diaphragm Material - 10th and 11th characters										
AISI 316 L ss	NACE				SM					
AISI 316 L ss - Low thickness	NACE				SL					
Hastelloy C-276	NACE				HM					
Hastelloy C-276 - Low thickness	NACE				HL					
Hastelloy C-2000	NACE				MM					
Inconel 625	NACE				LM					
Tantalum					TM					
AISI 316 L ss gold plated	NACE				NM					
AISI 316 L ss with PFA anti-stick coating	NACE				KM					
Hastelloy C-276 with PFA anti-stick coating	NACE				YM					
AISI 316 L ss with PFA coating anti-corrosion and anti-stick	NACE				WM					
Diaflex (AISI with anti-abrasion treatment)	NACE				FM					
Superduplex ss (UNS S32750 to ASTM SA479)	NACE				EM					
Monel	NACE				GM					
Seal Surface Finish - 12th character										
Serrated	(Note 1)					1				
Smooth						2				
Capillary Protection - 13th character										
AISI 316 L ss armour									A	
AISI 316 L ss armour with PVC protective cover									B	

continued
see next page

...Basic ordering information for model S26WA Wafer diaphragm seal to ASME B16.5

S 2 6 W A X X X X X X X X			X	X	X	X	X
Capillary Length m (Feet) - 14th character							
1 (3)			A				continued see next page
1.5 (5)			B				
2 (7)			C				
2.5 (8)			D				
3 (10)			E				
3.5 (12)			F				
4 (13)			G				
4.5 (15)			H				
5 (17)			J				
5.5 (18)			K				
6 (20)			L				
6.5 (22)			M				
7 (23.5)			N				
7.5 (25)			P				
8 (27)			Q				
9 (30)			R				
10 (33)			S				
12 (40)			T				
14 (47)			U				
16 (53)			V				
Fill Fluid - 15th character							
Silicone oil PMX 200 10 cSt	(-40 to 250 °C; -40 to 480 °F)						S
Silicone oil Baysilone PD5 5 cSt	(-85 to 250 °C; -121 to 480 °F)						P
Inert oil - Galden G5	(Oxygen service)	(Note 2)					N
Inert oil - Halocarbon 4.2	(Oxygen service)	(Note 2)					D
Silicone oil for high temperature	(-10 to 375 °C; 14 to 707 °F)						G
Silicone polymer Syltherm XLT	(-100 to 100 °C; -148 to 212 °F)						C
Mineral oil Esso Marcol 152	(FDA approved)	(Note 3)					W
Vegetable oil Neobee M-20	(FDA approved)	(Note 3)					A
Glycerin-water 70%	(FDA approved)	(Note 3)					B

...Ordering Information

...Basic ordering information for model S26WA Wafer diaphragm seal to ASME B16.5

S 2 6 W A X X X X X X X X X X		X	X	X
Flushing Ring: Hole and Thread - 16th character				
None		N		
1 hole - 1/2 in. NPT		2		
2 holes - 1/2 in. NPT		3		
1 hole - 1/4 in. NPT		4		
2 holes - 1/4 in. NPT		5		
Flushing Ring Material - 17th character				
None	(Note 4)			N
AISI 316 L ss	(Note 5)	NACE		A
Hastelloy C-276	(Notes 5, 6)	NACE		H
Flushing Ring: Plug and Gasket - 18th character				
No plug - No gasket				N
No plug - garlock	(Note 5)			A
No plug - PTFE	(Note 5)			B
No plug - graphite	(Note 5)			C
AISI 316 L ss - no gasket	(Notes 5, 7)	NACE		D
AISI 316 L ss - garlock	(Notes 5, 7)	NACE		E
AISI 316 L ss - PTFE	(Notes 5, 7)	NACE		F
AISI 316 L ss - graphite	(Notes 5, 7)	NACE		G
Hastelloy C-276 - no gasket	(Notes 5, 8)	NACE		H
Hastelloy C-276 - garlock	(Notes 5, 8)	NACE		L
Hastelloy C-276 - PTFE	(Notes 5, 8)	NACE		M
Hastelloy C-276 - graphite	(Notes 5, 8)	NACE		P

Note 1: Not available with diaphragm material code MM, LM, TM, NM, KM, YM, WM

Note 2: Suitable for oxygen service

Note 3: Suitable for food application

Note 4: Not available with Flushing ring: hole and thread code 2, 3, 4, 5

Note 5: Not available with Flushing ring: hole and thread code N

Note 6: Not available with Seal surface finish code 1

Note 7: Not available with Hastelloy C-276 flushing ring material code H

Note 8: Not available with AISI 316 L flushing ring material code A

Basic ordering information for model S26WE Wafer diaphragm seal to EN 1092-1

Select one character or set of characters from each category and specify complete catalog number.

BASE MODEL - 1st to 5th characters	S 2 6 W E	X	XX	X	XX	X	X	X	X	X	X
Wafer diaphragm seal to EN 1092-1											
Transmitter Side of Connection - 6th character											
High pressure side		H									
Low pressure side		L									
Mounting Flange Rating / Size - 7th and 8th characters											
EN 1092-1 DN 40			M5								
EN 1092-1 DN 50			N5								
EN 1092-1 DN 80			P5								
Extensions Length and Material - 9th character											
Flush						F					
Diaphragm Material - 10th and 11th characters											
AISI 316 L ss	NACE					SM					
AISI 316 L ss - Low thickness	NACE					SL					
Hastelloy C-276	NACE					HM					
Hastelloy C-276 - Low thickness	NACE					HL					
Hastelloy C-2000	NACE					MM					
Inconel 625	NACE					LM					
Tantalum						TM					
AISI 316 L ss gold plated	NACE					NM					
AISI 316 L ss with PFA anti-stick coating	NACE					KM					
Hastelloy C-276 with PFA anti-stick coating	NACE					YM					
AISI 316 L ss with PFA coating anti-corrosion and anti-stick	NACE					WM					
Diaflex (AISI with anti-abrasion treatment)	NACE					FM					
Superduplex ss (UNS S32750 to ASTM SA479)	NACE					EM					
Monel	NACE					GM					
Seal Surface Finish - 12th character											
Serrated	(Note 1)									1	
Smooth										2	
Form E - Spigot type	(Note 2)									4	
Form D - Groove type	(Note 3)									6	
Capillary Protection - 13th character											
AISI 316 L ss armour											A
AISI 316 L ss armour with PVC protective cover											B

continued
see next page

...Ordering Information

...Basic ordering information for model S26WE Wafer diaphragm seal to EN 1092-1

			S	2	6	W	E	X	X	X	X	X	X	X	X	
Capillary Length m (Feet) - 14th character																
1 (3)														A		continued see next page
1.5 (5)														B		
2 (7)														C		
2.5 (8)														D		
3 (10)														E		
3.5 (12)														F		
4 (13)														G		
4.5 (15)														H		
5 (17)														J		
5.5 (18)														K		
6 (20)														L		
6.5 (22)														M		
7 (23.5)														N		
7.5 (25)														P		
8 (27)														Q		
9 (30)														R		
10 (33)														S		
12 (40)														T		
14 (47)														U		
16 (53)														V		
Fill Fluid - 15th character																
Silicone oil PMX 200 10 cSt																S
Silicone oil Baysilone PD5 5 cSt																P
Inert oil - Galden G5															(Note 4)	N
Inert oil - Halocarbon 4.2															(Note 4)	D
Silicone oil for high temperature																G
Silicone polymer Syltherm XLT																C
Mineral oil Esso Marcol 152															(Note 5)	W
Vegetable oil Neobee M-20															(Note 5)	A
Glycerin-water 70%															(Note 5)	B

...Basic ordering information for model S26WE Wafer diaphragm seal to EN 1092-1

S 2 6 W E X X X X X X X X X X			X	X	X
Flushing Ring: Hole and Thread - 16th character					
None			N		
1 hole - 1/2 in. NPT	(Note 6)		2		
2 holes - 1/2 in. NPT	(Note 6)		3		
1 hole - 1/4 in. NPT	(Note 6)		4		
2 holes - 1/4 in. NPT	(Note 6)		5		
Flushing Ring Material - 17th character					
None	(Note 7)			N	
AISI 316 L ss	(Note 8)	NACE		A	
Hastelloy C-276	(Notes 8, 9)	NACE		H	
Flushing Ring: Plug and Gasket - 18th character					
No plug - No gasket					N
No plug - garlock	(Note 8)				A
No plug - PTFE	(Note 8)				B
No plug - graphite	(Note 8)				C
AISI 316 L ss - no gasket	(Notes 8, 10)	NACE			D
AISI 316 L ss - garlock	(Notes 8, 10)	NACE			E
AISI 316 L ss - PTFE	(Notes 8, 10)	NACE			F
AISI 316 L ss - graphite	(Notes 8, 10)	NACE			G
Hastelloy C-276 - no gasket	(Notes 8, 11)	NACE			H
Hastelloy C-276 - garlock	(Notes 8, 11)	NACE			L
Hastelloy C-276 - PTFE	(Notes 8, 11)	NACE			M
Hastelloy C-276 - graphite	(Notes 8, 11)	NACE			P

- Note 1: Not available with diaphragm material code MM, LM, TM, NM, KM, YM, WM
- Note 2: Not available with diaphragm material code SM, HM, MM, LM, TM, NM, KM, YM, WM, FM, EM
- Note 3: Not available with diaphragm material code SM, HM, HL, MM, LM, TM, NM, KM, YM, WM, FM, EM
- Note 4: Suitable for oxygen service
- Note 5: Suitable for food application
- Note 6: Not available with Seal surface finish code 4, 6
- Note 7: Not available with Flushing ring: hole and thread code 2, 3, 4, 5
- Note 8: Not available with Flushing ring: hole and thread code N
- Note 9: Not available with Seal surface finish code 1
- Note 10: Not available with Hastelloy C-276 flushing ring material code H
- Note 11: Not available with AISI 316 L flushing ring material code A

...Ordering Information

Basic ordering information for model S26CN Chemical Tee diaphragm seal

Select one character or set of characters from each category and specify complete catalog number.

BASE MODEL - 1st to 5th characters	S 2 6 C N	X	XX		XX	X	X	X	X
Chemical Tee seal									
Transmitter Side of Connection - 6th character									
High pressure side		H							
Low pressure side		L							
Mounting Flange - 7th character									
Integral with seal			G						
Size - 8th character									
3 in. Proprietary				P					
Diaphragm Material - 9th and 10th characters									
AISI 316 L ss	NACE				SM				
Hastelloy C-276	NACE				HM				
AISI 316 L ss with PFA anti-stick coating	NACE				KM				
Hastelloy C-276 with PFA anti-stick coating	NACE				YM				
AISI 316 L ss with PFA coating anti-corrosion and anti-stick	NACE				WM				
Diaflex (AISI with anti-abrasion treatment)	NACE				FM				
Capillary Protection - 11th character									
AISI 316 L ss armour								A	
AISI 316 L ss armour with PVC protective cover								B	
Capillary Length m (Feet) - 12th character									
1 (3)									A
1.5 (5)									B
2 (7)									C
2.5 (8)									D
3 (10)									E
3.5 (12)									F
4 (13)									G
4.5 (15)									H
5 (17)									J
6 (20)									L
7 (23.5)									N
8 (27)									Q
Fill Fluid - 13th character									
Silicone oil PMX 200 10 cSt	(-40 to 250 °C; -40 to 480 °F)								S
Silicone oil Baysilone PD5 5 cSt	(-85 to 250 °C; -121 to 480 °F)								P
Inert oil - Galden G5	(Oxygen service)	(Note 1)							N
Inert oil - Halocarbon 4.2	(Oxygen service)	(Note 1)							D
Silicone oil for high temperature	(-10 to 375 °C; 14 to 707 °F)								G
Silicone polymer Syltherm XLT	(-100 to 100 °C; -148 to 212 °F)								C
Mineral oil Esso Marcol 152	(FDA approved)	(Note 2)							W
Vegetable oil Neobee M-20	(FDA approved)	(Note 2)							A
Glycerin-water 70%	(FDA approved)	(Note 2)							B
Gasket - 14th character									
None									1
PTFE with silica filler									6
Graphite									7

Note 1: Suitable for oxygen service

Note 2: Suitable for food application

Basic ordering information for model S26BN Button type remote diaphragm seal

Select one character or set of characters from each category and specify complete catalog number.

BASE MODEL - 1st to 5th characters	S 2 6 B N	X	X	X	XX	X	X	X	X	X		
Button type remote diaphragm seal												
Transmitter Side of Connection - 6th character												
High pressure side											H	
Size - 7th character												
1 in.											M	
Mounting connection type - 8th character												
3 1/4 in. flange extended – type 91											A	
3 1/2 in. flange extended – type 91 modified											B	
1 1/2 in. 16N-2 threaded union – type 92											C	
Bracket – type 89											D	
Universal – type 90											E	
1 1/2 in. 12NF threaded union – type 92 modified											F	
Diaphragm Material - 9th and 10th characters												
Hastelloy C-276											NACE	HL
Capillary Protection - 11th character												
AISI 316 L ss armour											A	
AISI 316 L ss armour with PVC protective cover											B	
Capillary Length m (Feet) - 12th character												
1 (3)											A	
1.5 (5)											B	
2 (7)											C	
2.5 (8)											D	
3 (10)											E	
Fill Fluid - 13th character												
Silicone oil PMX 200 10 cSt (-40 to 250 °C; -40 to 480 °F)											S	
Silicone oil for high temperature (-10 to 375 °C; 14 to 707 °F)											G	
Mineral oil Esso Marcol 152 (FDA approved) (Note 1)											W	
Option - 14th character												
None											1	
Jack out collar for seal removal for process (not for type 89) (Note 2)											2	
Gasket - 15th character												
None											1	
Aluminium											E	
AISI 316 ss											F	

Note 1: Suitable for food application

Note 2: Not available with mounting connection types code D

...Ordering Information

Basic ordering information for model S26UN Union connection remote diaphragm seal

Select one character or set of characters from each category and specify complete catalog number.

BASE MODEL - 1st to 5th characters	S 2 6 U N	X	X	XX	X	X	X	X	X
Union connection remote diaphragm seal									
Transmitter Side of Connection - 6th character									
High pressure side		H							
Size - 7th character									
1 1/2 in.			L						
Diaphragm Material - 8th and 9th characters									
AISI 316 L ss		NACE		SL					
Hastelloy C-276		NACE		HL					
Capillary Protection - 10th character									
AISI 316 L ss armour							A		
AISI 316 L ss armour with PVC protective cover							B		
Capillary Length m (Feet) - 11th character									
1 (3)								A	
1.5 (5)								B	
2 (7)								C	
2.5 (8)								D	
3 (10)								E	
3.5 (12)								F	
4 (13)								G	
4.5 (15)								H	
5 (17)								J	
Fill Fluid - 12th character									
Silicone oil PMX 200 10 cSt	(-40 to 250 °C; -40 to 480 °F)								S
Silicone oil Baysilone PD5 5 cSt	(-85 to 250 °C; -121 to 480 °F)								P
Inert oil - Galden G5	(Oxygen service)	(Note 1)							N
Inert oil - Halocarbon 4.2	(Oxygen service)	(Note 1)							D
Silicone oil for high temperature	(-10 to 375 °C; 14 to 707 °F)								G
Silicone polymer Syltherm XLT	(-100 to 100 °C; -148 to 212 °F)								C
Mineral oil Esso Marcol 152	(FDA approved)	(Note 2)							W
Vegetable oil Neobee M-20	(FDA approved)	(Note 2)							A
Glycerin-water 70%	(FDA approved)	(Note 2)							B
Process Fitting Connections - 13th character									
Not required									1
AISI 316 ss weld bushing									3
Chemical tee flange									4
Gasket - 14th character									
Not required									1
Silicone rubber									5
PTFE									8

Note 1: Suitable for oxygen service
 Note 2: Suitable for food application

Basic ordering information for model S26PN Urea service remote diaphragm seal

Select one character or set of characters from each category and specify complete catalog number.

BASE MODEL - 1st to 5th characters	S 2 6 P N	X	X	X	XX	X	X	X	X
Urea service remote diaphragm seal									
Transmitter Side of Connection - 6th character									
High pressure side		H							
Low pressure side		L							
Size / Mounting Flange Rating / Material - 7th character									
3 in. / ASME 600 RF integral flange / AISI 316 L ss Urea Grade			H						
2 in. / ASME 2500 threaded flange / Carbon steel			J						
Extension length / diameter - 8th character									
40.3 mm (1.59 in.) / 69 mm (2.71 in.)	(Note 1)				R				
40.3 mm (1.59 in.) / 94 mm (3.7 in.)	(Note 1)				S				
131 mm (5.16 in.) / 37.5 mm (1.47 in.)	(Note 2)				T				
Diaphragm Material - 9th and 10th characters									
AISI 316 L ss Urea Grade						SM			
Capillary Protection - 11th character									
AISI 316 L ss armour							A		
AISI 316 L ss armour with PVC protective cover							B		
Capillary Length m (Feet) - 12th character									
1 (3)								A	
1.5 (5)								B	
2 (7)								C	
2.5 (8)								D	
3 (10)								E	
3.5 (12)								F	
4 (13)								G	
4.5 (15)								H	
5 (17)								J	
5.5 (18)	(Note 1)							K	
6 (20)	(Note 1)							L	
Fill Fluid - 13th character									
Silicone oil PMX 200 10 cSt	(-40 to 250 °C; -40 to 480 °F)								S
Silicone oil for high temperature	(-10 to 375 °C; 14 to 707 °F)								G
Certification - 14th character									
None									1
Huey test									3

Note 1: Not available with Size/Mounting flange code J

Note 2: Not available with Size/Mounting flange code H

...Ordering Information

Basic ordering information for model S26KN Pulp and paper diaphragm seal

Select one character or set of characters from each category and specify complete catalog number.

BASE MODEL - 1st to 5th characters	S 2 6 K N	X	X	XX	X	X	X	X
Pulp and paper diaphragm seal								
Transmitter Side of Connection - 6th character								
High pressure side		H						
Size / Mounting connection - 7th character								
1 in. pulp and paper seal - sealing with gaskets to spud (NOT AVAILABLE WITH SENSOR F AND S)			U					
1 1/2 in. pulp and paper seal - sealing with gasket to spud (NOT AVAILABLE WITH SENSOR S)			K					
1 in. pulp and paper seal with 1 in. NPT male threaded connection (NOT AVAILABLE WITH SENSOR F)			W					
1 1/2 in. pulp and paper seal with 1 1/2 in. NPT male threaded connection			Z					
1 in. pulp and paper seal with G 1 in. A male threaded connection (NOT AVAILABLE WITH SENSOR F)			1					
1 1/2 in. pulp and paper seal with G 1 1/2 in. A male threaded connection			2					
1 in. pulp and paper seal with ball valve connection (NOT AVAILABLE WITH SENSOR F AND S and 266NRH)			Y					
1 1/2 in. pulp and paper seal - sealing with gasket to M44 threaded spud (NOT AVAILABLE WITH SENSOR S)			V					
Diaphragm Material - 8th and 9th characters								
AISI 316 L ss	(Note 1)		SL					
Hastelloy C-276			HL					
Diaflex (AISI with anti-abrasion treatment)	(Note 1)		FL					
Capillary Protection - 10th character								
Extension tube for direct mount seal					N			
Capillary Length m (Feet) - 11th character								
Direct-mount construction						1		
Fill Fluid - 12th character								
Silicone oil PMX 200 10 cSt	(-40 to 250 °C; -40 to 480 °F)							S
Mineral oil Esso Marcol 152	(FDA approved)	(Note 5)						W
Clamp/Fittings - 13th character								
Not required								N
Weld-on spud and fixing screw for 1 in. pulp & paper seal connection	(Note 2)							C
Weld-on threaded spud for 1 1/2 in. pulp & paper seal connection	(Note 3)							D
Weld-on spud and fixing screws for 1 1/2 in. pulp & paper seal connection	(Note 4)							F

Note 1: Not available with connection code Y
 Note 2: Suitable ONLY for 1 in. size - sealing with gaskets code U
 Note 3: Suitable ONLY for 1-1/2 in. size to M44 threaded spud - sealing with gaskets code V
 Note 4: Suitable ONLY for 1-1/2 in. size - sealing with gaskets code K
 Note 5: Suitable for food application

Basic ordering information for model S26JN In-line diaphragm seals

Select one character or set of characters from each category and specify complete catalog number.

BASE MODEL - 1st to 5th characters	S 2 6 J N	X	X	XX	X	X	X
In-line diaphragm seal							
Transmitter Side of Connection - 6th character							
High pressure side		H					
Size / Mounting connection - 7th character							
DN 25 / 1 in.			A				
DN 40 / 1 1/2 in.			B				
DN 50 / 2 in.			C				
DN 80 / 3 in.			D				
Diaphragm Material - 8th and 9th characters							
AISI 316 L ss	NACE			SM			
Hastelloy C-276	NACE			HM			
Capillary Protection - 10th character							
Extension tube for direct mount seal						N	
Capillary Length m (Feet) - 11th character							
Direct-mount construction							1
Fill Fluid - 12th character							
Silicone oil PMX 200 10 cSt	(-40 to 250 °C; -40 to 480 °F)						S
Silicone oil Baysilone PD5 5 cSt	(-85 to 250 °C; -121 to 480 °F)						P
Inert oil - Galden G5	(Oxygen service)	(Note 1)					N
Inert oil - Halocarbon 4.2	(Oxygen service)	(Note 1)					D
Silicone oil for high temperature	(-10 to 375 °C; 14 to 707 °F)						G
Silicone polymer Syltherm XLT	(-100 to 100 °C; -148 to 212 °F)						C
Mineral oil Esso Marcol 152	(FDA approved)	(Note 2)					W
Vegetable oil Neobee M-20	(FDA approved)	(Note 2)					A
Glycerin-water 70%	(FDA approved)	(Note 2)					B

Note 1: Suitable for oxygen service
 Note 2: Suitable for food application

IMPORTANT REMARK FOR ALL MODELS

THE SELECTION OF SUITABLE WETTED PARTS AND FILLING FLUID FOR COMPATIBILITY WITH THE PROCESS MEDIA IS A CUSTOMER'S RESPONSIBILITY, IF NOT OTHERWISE NOTIFIED BEFORE MANUFACTURING.

NACE COMPLIANCE INFORMATION

- 1 The materials of constructions comply with metallurgical recommendations of NACE MR0175/ISO 15156 for sour oil field production environments. As specific environmental limits may apply to certain materials, please consult latest standard for further details. AISI 316/316 L, Hastelloy C-276, Monel 400 also conform to NACE MR0103 for sour refining environments.
- 2 NACE MR-01-75 addresses bolting requirements in two classes:
 - Exposed bolts: bolts directly exposed to the sour environment or buried, encapsulated or anyway not exposed to atmosphere
 - Non exposed bolts: the bolting must not be directly exposed to sour environments and must be directly exposed to the atmosphere at all times.

266DRH bolting identified by "NACE (non exposed)" are in compliance with requirements of NACE MR0103 when considered "non exposed bolting".

266DRH bolting identified by "NACE" are in compliance with requirements of NACE MR0175 when considered "exposed bolting"

- ® Hastelloy is a registered trademark of Haynes International
- ® Monel and Inconel are registered trademarks of Special Metals Corporation
- ® Viton is a registered trademark of E.I. DuPont de Nemour
- ® PMX 200 and Syltherm are registered trademarks of Dow Corning Corporation
- ® Galden is a registered trademark of Solvay Group
- ® Halocarbon is a registered trademark of Halocarbon Products Co.
- ® Baysilone is a registered trademark of Bayer
- ® Neobee is a registered trademark Stepan Specialty Products, LCC
- ® Esso Marcol 152 is a registered trademark Esso Italiana
- ® HART and WirelessHART are registered trademarks of HART Communication Foundation
- ® PROFIBUS is a registered trademark of Profibus International
- ™ FOUNDATION Fieldbus is a trademark of Fieldbus Foundation

ABB Ltd.**Measurement & Analytics**

Howard Road St. Neots
Cambridgeshire PE19 8EU
UK

Tel: +44 (0)1480 475321

Fax: +44 (0)1480 217948

ABB S.p.A.**Measurement & Analytics**

Via Luigi Vaccani 4
22016 Tremezzina (CO)
Italy

Tel: +39 0344 58111

ABB Inc.**Measurement & Analytics**

125 E. County Line Road
Warminster PA 18974

USA

Tel: +1 215 674 6000

Fax: +1 215 674 7183

abb.com/measurement

We reserve the right to make technical changes or modify the contents of this document without prior notice. With regard to purchase orders, the agreed particulars shall prevail. ABB does not accept any responsibility whatsoever for potential errors or possible lack of information in this document.

We reserve all rights in this document and in the subject matter and illustrations contained therein. Any reproduction, disclosure to third parties or utilization of its contents – in whole or in parts – is forbidden without prior written consent of ABB.