

**PR**  
electronics



**2289**

**Signal calculator**

Nr. 2289V101-UK

From ser. no. 980338001

**EAC**



- DK** ▶ PR electronics A/S tilbyder et bredt program af analoge og digitale signalbehandlingsmoduler til industriel automation. Programmet består af Isolatorer, Displays, Ex-barrierer, Temperaturtransmittere, Universaltransmittere mfl. Vi har modulerne, du kan stole på i selv barske miljøer med elektrisk støj, vibrationer og temperaturudsving, og alle produkter opfylder de strengeste internationale standarder. Vores motto »Signals the Best« er indbegrebet af denne filosofi - og din garanti for kvalitet.
- UK** ▶ PR electronics A/S offers a wide range of analog and digital signal conditioning devices for industrial automation. The product range includes Isolators, Displays, Ex Interfaces, Temperature Transmitters, and Multifunctional Devices. You can trust our products in the most extreme environments with electrical noise, vibrations and temperature fluctuations, and all products comply with the most exacting international standards. »Signals the Best« is the epitome of our philosophy - and your guarantee for quality.
- FR** ▶ PR electronics A/S offre une large gamme de produits pour le traitement des signaux analogiques et numériques dans tous les domaines industriels. La gamme de produits s'étend des transmetteurs de température aux afficheurs, des isolateurs aux interfaces SI, jusqu'aux modules universels. Vous pouvez compter sur nos produits même dans les conditions d'utilisation sévères, p.ex. bruit électrique, vibrations et fluctuations de température. Tous nos produits sont conformes aux normes internationales les plus strictes. Notre devise »SIGNALS the BEST« c'est notre ligne de conduite - et pour vous l'assurance de la meilleure qualité.
- DE** ▶ PR electronics A/S verfügt über ein breites Produktprogramm an analogen und digitalen Signalverarbeitungsgeräte für die industrielle Automatisierung. Dieses Programm umfasst Displays, Temperaturtransmitter, Ex- und galvanische Signaltrenner, und Universalgeräte. Sie können unsere Geräte auch unter extremen Einsatzbedingungen wie elektrisches Rauschen, Erschütterungen und Temperaturschwingungen vertrauen, und alle Produkte von PR electronics werden in Übereinstimmung mit den strengsten internationalen Normen produziert. »Signals the Best« ist Ihre Garantie für Qualität!

# SIGNAL CALCULATOR

## Type 2289

### CONTENTS

How to dismantle system 2200.....	2
Application.....	3
Technical characteristics.....	3
Functions .....	3
Analogue calculator .....	3
Sample-hold.....	3
Peak-Hold.....	4
Delay .....	4
PID controller .....	4
Manual / automatic controller.....	4
Signal limiter.....	4
Averaging transmitter.....	4
Slope transmitter (di/dt function).....	4
Analogue multiplexer .....	5
Inputs.....	5
Analogue inputs - 2289A.....	5
Pt100 input - 2289B.....	5
Digital input - 2289A.....	5
Output.....	5
Electrical specifications.....	6
Order: 2289.....	8
Block diagram -2289A.....	9
Block diagram -2289B.....	10
Hardware programming.....	11
Jumper positioning .....	12
External up / down operation of manual controller .....	12
Routing diagram.....	13
Programming / operating the function keys .....	14
Function description (selection of application).....	23
Graphic illustration of the functions.....	28

## HOW TO DISMANTLE SYSTEM 2200

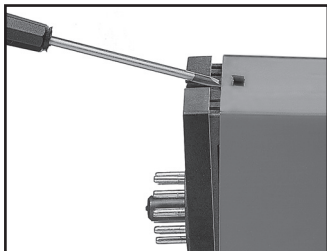

**Picture 1:**

The back panel of the module is detached from the housing by way of a screwdriver.

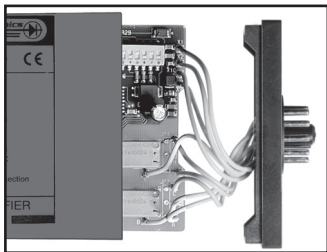

**Picture 2:**

After this, the back panel can be pulled out together with the PCB, but please notice the position of the PCB as there is a number of different positions in the house. Do not pull the wires unnecessarily, instead pull the PCB. Switches and jumpers can now be moved.

When assembling the back plate and housing, please make sure no wires are stuck.

# SIGNAL CALCULATOR 2289

- *Two analogue inputs*
- *Multiple functions*
- *Front-programmable*
- *3-digit LED display*
- *Version with a Pt100 input*
- *Analogue output*

## Application

Operates as a PID controller with an analogue or a Pt100 input, a manual / automatic controller, an analogue calculator with a scale function on both inputs, a sample-hold transmitter, a peak-hold transmitter, a delay transmitter, a signal limiter, averaging of noisy signals, monitoring of a signal's slope, or an analogue multiplexer. • The 2289 Signal Calculator will meet the demands of any process engineer with an unexpected or special signal processing assignment at hand.

## Technical characteristics

The unit is built around a microprocessor core with an efficient program operation. The basic calibration data and the present set-up are saved in an EEPROM thereby avoiding the loss or change of data at power off. The user interface consists of a 3-digit display and 3 front function keys. The input and output values, function, and all parameter selections are entered by means of the user interface. Both the input signals and the output signal can be inverted.

## Functions

### Analogue calculator

Contains the following calculation functions: addition, subtraction, maximum / minimum selection, multiplication, division, raising to a power and root extraction. At raising to a power and root extraction, any of the analogue inputs can be selected. By means of the scale function the calculation functions can be executed on differently scaled input signals.

### Sample-hold

Activation of the digital input (hold) will set the output value to the present input value and will hold this value for as long as the digital input is active. At a deactivated digital input the output value will track the input value.

### **Peak-Hold**

At a deactivated digital input the output value is the greatest input value registered since the last reset. Activation of the digital input will set the output value at the present input value (reset).

### **Delay**

The delay function transfers the input value to the output according to an exponential curve (R/C delay), where the time constant of the R/C delay can be entered.

### **PID controller**

Features the following regulation parameters: XP (proportional band), TI (integrating time), and TD (differentiating time). The units are selected as XP %, TI s, and TD s. By selecting TI and TD as 0, the function will be a pure proportional controller. The regulation can be either direct or inverted. The setpoint can be selected as an internal or external current / voltage signal.

### **Manual / automatic controller**

The digital input is used to change between the manual and automatic mode. In the automatic mode the analogue output follows input A. When changing to the manual mode the analogue output is fixed and can now be activated up or down manually. The output holds the manual setting for an unlimited period.

### **Signal limiter**

By the signal limiting function the output follows the input values linearly in the range between the min. and max. settings. At input signals outside the min. and max. settings, the output is fixed on either the min. or the max. value. the min. or the max. value can be set externally by means of the other analogue input.

### **Averaging transmitter**

The averaging function calculates an accurate average value of the input values over a set period. Once this period has expired the output will be updated by the average value. This means that the output will typically make a jump at each update. A stack function can be selected to increase the updates of the output and to decrease any jumps while still keeping the set averaging period.

### **Slope transmitter (dl/dt function)**

The dl/dt function converts the slope of the input over a set period to an analogue output signal. The min. and max. slope to be converted are entered in % of the input span. The slope can be selected as either positive or negative. By means of a pressure transmitter the dl/dt function is suitable for for instance leak monitoring or flow measurement of substances with a high viscosity grade.

## **Analogue multiplexer**

At a deactivated digital input, input A x P1 is sent to the output. At an activated digital input, input B x P2 is sent to the output. P1 and P2 are scaling factors for the two inputs.

## **Inputs**

### **Analogue inputs - 2289A**

The A and B inputs can be programmed according to your choice to receive current signals in the range 0...20 mA (for instance 4...20 mA), or voltage signals in the range 0...10 VDC.

### **Pt100 input - 2289B**

Input A is a linearised Pt100 temperature input in the range -99...+850°C with a 3-wire connection. The measurement range can be scaled via the front keys acc. to your choice. As 2289A, input B is an analogue current / voltage input.

### **Digital input - 2289A**

By way of JP6 the 2289 signal calculator can be programmed to NPN (pull up to 24 VDC), or PNP (pull down to 0 VDC). Min. pulse length is 50 ms.

## **Output**

Analogue standard current / voltage output of 0/4...20 mA / 0/2...10 VDC. The output span can be set to special current / voltage signals acc. to your choice. Max. load on the current output is 600 Ω. Min. load on the voltage output is 500 kΩ.

## Electrical specifications

### Specifications range:

-20 to +60°C

### Common specifications:

Supply voltage .....	19.2...28.8 VDC
Internal consumption .....	2.4 W
Max. consumption.....	2.7 W
Signal / noise ratio .....	Min. 60 dB
Signal dynamics, input.....	20 bit
Signal dynamics, output .....	16 bit
Proportional band (XP) .....	0.01...999%
Gain.....	0.1...10000
Integrating time (TI).....	0...999 s
Differentiating time (TD).....	0...999 s
Response time .....	< 60 ms
Updating time .....	20 ms
Calibration temperature .....	20...28°C
Temperature coefficient.....	< ±0.01% of span/°C
Linearity error .....	< ±0.1% of span
Effect of supply voltage change.....	< ±0.002% of span/%V
Auxiliary voltages:	
Reference voltage .....	2.5 VDC ±0.5% / 15 mA
EMC immunity influence .....	< ±0.5%
Relative air humidity .....	< 95% RH (non-cond.)
Dimensions (HxWxD) (D is excl. pins).....	80.5 x 35.5 x 84.5 mm
Protection degree.....	IP50
Weight .....	130 g

### Electrical specifications - INPUT:

#### Current input:

Measurement range.....	0...20 mA
Min. measurement range (span) .....	4 mA
Max. offset .....	50% of selec. max. value
Input resistance.....	Nom. 50 Ω



**Voltage input:**

Measurement range.....	0...10 VDC
Min. measurement range (span) .....	200 mV
Max. offset .....	50% of selec. max. value
Input resistance .....	Nom. 10 M $\Omega$

**Digital input:**

NPN .....	Pull up 24 VDC / 6.9 mA
PNP .....	Pull down 0 VDC / 6.9 mA
Pulse length.....	> 50 ms

**Pt100 input 2289B:**

Measurement range.....	-99...+850°C
Min. measurement range (span) .....	50°C
Max. offset .....	50% of selec. max. value
Cable resistance per wire (max.) .....	25 $\Omega$
Sensor current.....	Nom. 1.25 mA
Response time .....	< 100 ms
Basic accuracy.....	< $\pm 0.2^\circ\text{C}$
Temperature coefficient:	
span < 100°C .....	< $\pm 0.01^\circ\text{C}/^\circ\text{Camb.}$
span > 100°C .....	< $\pm 0.01\%$ of span/ $^\circ\text{Camb.}$
Immunity influence:	
span < 100°C .....	< $\pm 1\%$ of span
span > 100°C .....	< $\pm 0.5\%$ of span
Effect of sensor cable resistance .....	< 0.002 $\Omega/\Omega$

**Electrical specifications - OUTPUT:****Current output:**

Signal range .....	0...20 mA
Min. signal range (span) .....	5 mA
Max. offset .....	50% of selec. max. value
Load (max.).....	20 mA / 600 $\Omega$ / 12 VDC
Load stability.....	< $\pm 0.01\%$ of span/100 $\Omega$
Current limit.....	20.5 mA

**Voltage output via internal shunt:**

Signal range .....	0...10 VDC
Min. signal range (span) .....	250 mV
Max. offset .....	50% of selec. max. value
Load (min.) .....	500 k $\Omega$
Voltage limit .....	10.25 VDC

**Observed authority requirements:**

EMC 2004/108/EC .....	EN 61326-1
EAC TR-CU 020/2011 .....	EN 61326-1

**Standard:**

Of span = Of the presently selected range

**Order: 2289**

Type	Inputs
2289	Current / voltage : A
	Pt100 & current / voltage : B

# BLOCK DIAGRAM -2289A

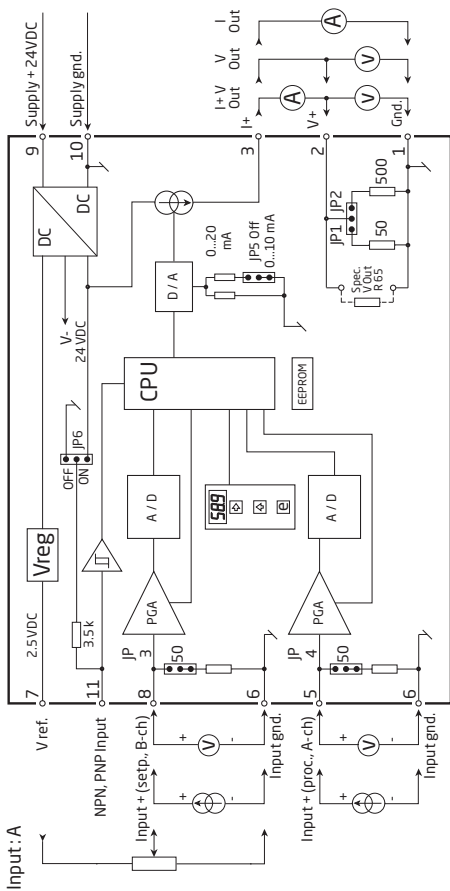

# BLOCK DIAGRAM -2289B

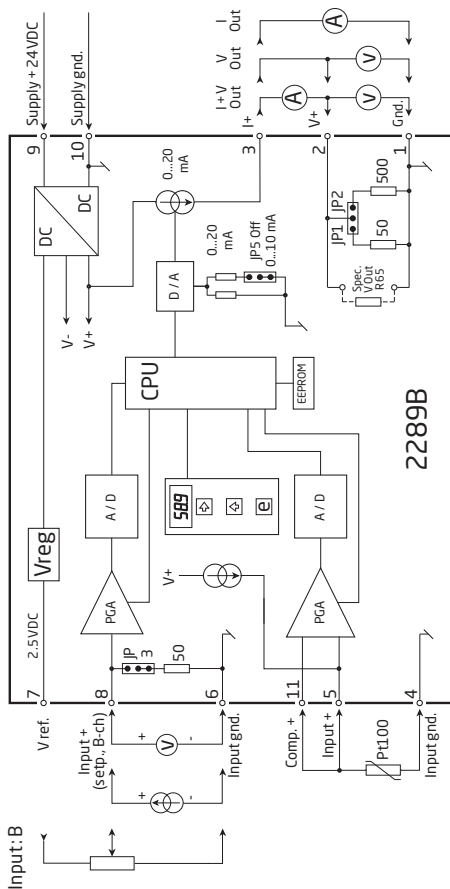

## HARDWARE PROGRAMMING

### Input:

<b>Channel A</b> 0...20 mA 0...10 VDC	JP4 JP4	ON OFF	MENU 2.3 = I MENU 2.3 = U
<b>Channel B</b> 0...20 mA 0...10 VDC	JP3 JP3	ON OFF	MENU 3.3 = I MENU 3.3 = U
NPN PNP	JP6 JP6	ON OFF	

### Output:

Output	JP1	JP2	JP5	MENU 4.3
0...10 mA 0...20 mA	OFF	OFF	OFF ON	1 2
0...500 mV 0...1000 mV	ON	OFF	OFF ON	3 4
0...5 V 0...10 V	OFF	ON	OFF ON	5 6

## Jumper positioning

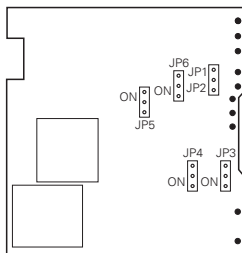

## External up / down operation of manual controller

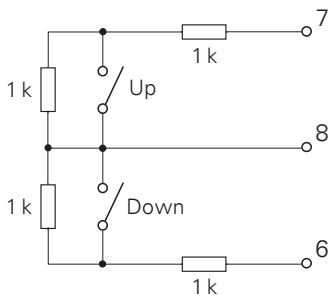

# Routing diagram

If no buttons are pressed for a period of 20 minutes, the display returns to default 0.0.

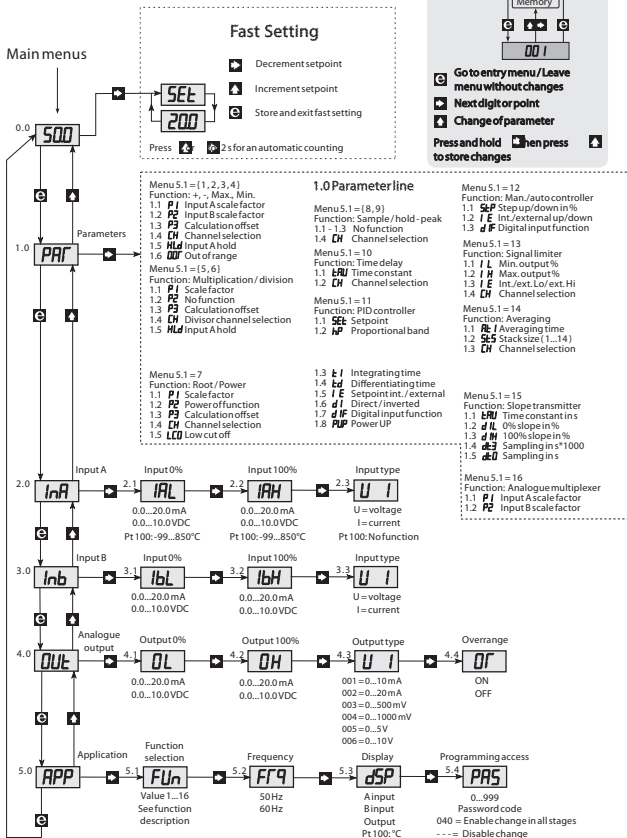





# PROGRAMMING / OPERATING THE FUNCTION KEYS

## DOCUMENTATION FOR ROUTING DIAGRAM



### General:

The programming is menu-controlled. The main menus are numbered in level 0 (x.0), and the submenus are numbered in level 1 (x.1 to x.5). Each submenu has an accompanying entry menu. The menus are structured in such a way that the menus most frequently used are closer to the default menu 0.0. Please note that programming is only possible when submenu 5.4 PAS has the value 040.

Submenus and branches are selected by the 3 function keys ,  and  as outlined in the routing diagram.



Activating  in the branches will display the current value of the entry and parameter selection menus.

In entry menus, the digit that can be changed will flash.

Active digit position is shifted by the  key, and the value is changed by the  key.

When the decimal point flashes, its position can be changed by the  key.

In parameter selection menus you switch between the parameters by the  key.

Save by first activating  and then  simultaneously.

To return to the previous menu without changing the parameters, activate 2.

If a non-valid value is entered, the display will show Err for 2 s and then return to the entry menu with the initial value.

### 0.0 Default - menu 5.3 displays the selection - dSP

The display returns to default at power ON, or if no keys have been activated for a period of 20 minutes.

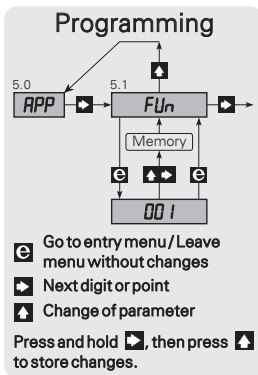



## Fast setting short cut key

When the PID controller with an internal setpoint has been selected, a fast setting is possible by way of the Fast Setting function. In this menu the function keys have a special function as 3 downcounts the setpoint and 1 upcounts the setpoint from the value it had when activated. Activate 2 to save the setpoint value displayed and to leave the Fast Setting menu. The setpoint value is displayed in % of the input span.

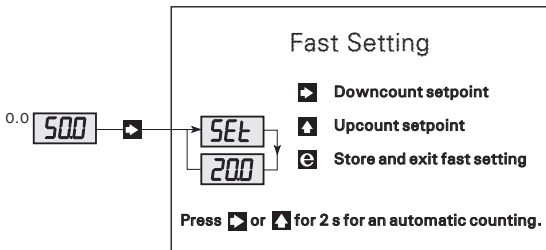

## 1.0 PAr - Parameter menu - entry of parameters

The parameter menu line differs according to the selection made in menu 5.1 - FUn. Please see the function description and applied expression in menu 5.1 - FUn. At the calculation functions, the 0...100% input and output spans are converted to values between 0 and 1. A scale factor of 1 means that the input signal is scaled to its full value. A scale factor of 0.5 means that the input signal is scaled to half its value.

### 1.0 PAr for Addition, Subtraction, Max. and Min. [Function no. 1, 2, 3, and 4]

#### 1.1 P1 - Scale factor for input A

A typical value is 0.5 for addition and 1.0 for subtraction, max. and min.  
Valid selections are -99...999. [Factor]

#### 1.2 P2 - Scale factor for input B

A typical value is 0.5 for addition and 1.0 for subtraction, max. and min.  
Valid selections are -99...999. [Factor]

#### 1.3 P3 - Calculation offset

A typical value is 0.0.  
Valid selections are -99...999. [Factor]

#### **1.4 CH - Input for subtraction**

If A has been selected the result is  $A - B$ .

If B has been selected the result is  $B - A$ .

Possible selections are A or B. [Input]

#### **1.5 Hld - Fixing of signal on input A**

When the digital input is active, the input signal is fixed on the value it had when activated.

Max. and Min. functions are not available.

Possible selections are EnA [Enable hold], or dSA [Disable hold].

#### **1.6 00r - Input signal less than the selected 0% value**

When the selected input span of the A and B channels is for instance 4...20 mA, input signals smaller than the selected 0% value (4 mA) will be considered negative signals. As the mathematical rules for operational signs apply to the calculation functions some may consider this calculation incorrect.

When ON has been selected there is no limit on the input signals.

When OFF has been selected the input signals' influence on the calculation functions is limited to 0...100% input span.

Max. and Min. functions are not available.

Possible selections are ON or OFF. [Allow negative signals]

### **1.0 PAr for Multiplication and Division. [Function no. 5 and 6]**

#### **1.1 P1 - Scale factor**

A typical value is 1.0.

Valid selections -99...999. [Factor]

#### **1.2 P2 - No function**

#### **1.3 P3 - Calculation offset**

A typical value is 0.0.

Valid selections are -99...999. [Factor]

#### **1.4 CH - Selection of input at division**

If A has been selected the result is  $A/B$ .

If B has been selected the result is  $B/A$ .

Possible selections are A or B. [Input]

### **1.5 HLD - Hold of signal on input A**

When the digital input is active, the input signal is held at the value it had when activated.

Possible selections are EnA [Enable hold], or dSA [Disable hold].

## **1.0 PAR for root extraction and raising to a power. [Function no. 7]**

### **1.1 P1 - Scale factor**

A typical value is 1.0.

Possible selections are -99...999. [Factor]

### **1.2 P2 - Exponent**

A value of 00.5 is the square root of the input signal, and 002 is the input signal raised to the second power.

Valid selections are -99...999. [Exponent]

### **1.3 P3 - Calculation offset**

A typical value is 0.0.

Valid selections are -99...999. [Factor]

### **1.4 CH - Input**

Possible selections are A or B. [Input]

### **1.5 LCO - Cut off low values**

The values are entered in % of the input span. Input values smaller than LCO are considered a 0% input signal.

A typical value is 0.5 for root extraction and 0.0 for power.

Valid selections are 0...100. [Per cent]

## **1.0 PAR for Hold and Peak. [Function no. 8 and 9]**

### **1.1 P1 - No function**

### **1.2 P2 - No function**

### **1.3 P3 - No function**

### **1.4 CH - Input**

Possible selections are A or B. [Input]

## **1.0 PAR for Delay. [Function no. 10]**

### **1.1 tAU - Time constant**

Valid selections are 0...999. [Seconds]

### **1.2 CH - Input**

Possible selections are A or B. [Input]

## **1.0 PAr for PID controller. [Function no. 11]**

### **1.1 S<sub>Et</sub> - Setpoint**

The setpoint value is entered in % of the input span.

Valid selections are 0...99.9. [Per cent]

### **1.2 h<sub>P</sub> - Proportional band**

The proportional band is entered in % of the input span.

Valid selections are 0.1...999. [Per cent]

### **1.3 t<sub>I</sub> - Integrating time**

The integrating time is entered in seconds.

Valid selections are 0...999. [Seconds]

### **1.4 t<sub>D</sub> - Differentiating time**

The differentiating time is entered in seconds.

Valid selections are 0...999. [Seconds]

### **1.5 I<sub>E</sub> - Internal or external setpoint**

When internal has been selected, input B is disabled, and the setpoint value is set in menu 1.1.

When external has been selected, input B is the setpoint. The signal type and measurement range of input B are set in menu 3.0.

The selection made is overruled by the selection of ISP in menu 1.7.

Possible selections are I - [Internal], or E - [External].

### **1.6 d<sub>I</sub> - Direct / Inverted controlling method**

When direct has been selected, a process value > the setpoint will result in an increasing output value. When inverted has been selected, a process value > the setpoint will result in a decreasing output value.

Possible selections are dI<sub>R</sub> - [Direct], or InU - [Inverted].

### **1.7 d<sub>I</sub>F - Digital input function**

When - ISP - has been selected, a deactivated digital input will select an internal setpoint, and an activated digital input will select an external setpoint. The ISP selection overrules the internal setpoint (I<sub>E</sub>) in menu 1.5.

When - HLd - has been selected, a deactivated digital input will result in a normal PID control of the output, and an active digital input will hold the output value and stop the integrator.

When - OFF - has been selected, the digital input has no function.

Possible selections are ISP, HLd or OFF. [Digital input]

### **1.8 PUP - Integration value at power on**

When - rES - has been selected, the integration value is reset at power on. When - HLd - has been selected, the integration value present prior to power off is applied at power on.

Possible selections are rES or HLd. [Integration value]

## **1.0 PAr for Manual / Automatic controller / Signal simulator. [Function no. 12]**

### **1.1 StP - Percentage value for step up and down**

Selection of the percentage value that the output must jump whenever an up or down signal is detected.

Valid selections are 0...99.9. [Per cent]

### **1.2 IE - Internal or external up / down**

When - I - has been selected and the display is in default menu 0.0, the output will jump by the value set in menu 1.1 each time the arrow keys are activated.

When - E - has been selected, an external current / voltage signal can be applied for the up / down function. To select down, a signal < 40% of the input span must be connected. To select up, a signal > 60% of the input span must be connected.

Both internal and external have a repeat function meaning that a continued activation will result in an up / down function with an increasing rate.

Possible selections are I - [Internal], or E - [External].

### **1.3 dIF - Selection of digital input function**

When - InP - has been selected, a deactivated digital input will result in the autofunction where the input A value is transferred to the output. An activated digital input will result in the manual function where the output adopts the value of input A at power on. Now the output value can be activated up or down manually.

When - OFF - has been selected, the function is compulsory auto.

When - ON - has been selected, the function is compulsory manual.

Possible selections are InP, OFF, or On. [Digital input]

## **1.0 PAr for Signal limiter. [Function no. 13]**

### **1.1 IL - Minimum output value**

The minimum output value is entered in % of the output span.

Valid selections are 0...100. [Per cent].

### **1.2 IH - Maximum output value**

The maximum output value is entered in % of the output span.  
Possible selections are 0...100. [Per cent]

### **1.3 IE - Internal / external signal limiter**

When - I - has been selected, the other analogue input is disabled, and the signal limiting follows the set IL and IH values.

When - EL - has been selected, the high limit will follow the set IH value, while the low limit will follow the other analogue input.

When - EH - has been selected, the low limit will follow the set IL value, while the high limit will follow the other analogue input.

Possible selections are I - [Internal], EL - [External low], or EH - [External high].

### **1.4 CH - Input**

The input that the output must follow.

Possible selections are A or B. [Input].

## **1.0 PA<sub>r</sub> for averaging. [Function no. 14]**

### **1.1 AtI - Averaging time**

The time in seconds that the input is averaged before it is sent to the output.

Valid selections are 0.1...999. [Seconds]

### **1.2 StS - Stack size**

Number of memories. The time between the updates of the output is AtI divided by StS.

Valid selections are 1...14. [Memories]

### **1.3 CH - Input**

The input that is averaged before it is sent to the output.

Possible selections are A or B. [Input]

## **1.0 PA<sub>r</sub> for slope transmitter (Input A). [Function no. 15]**

### **1.1 tAU - Time constant for exponential averaging of the input**

Valid selections are 0.00...999. [Seconds]

### **1.2 dIL - Smallest slope for 0% output value**

The slope in % of the input span that must correspond to the 0% output signal.

A typical value is 0.0.

Valid selections are -99...100. [Per cent]

### **1.3 dIH - Greatest slope for 100% output value**

The slope in per cent of the input span that must correspond to the 100% output signal.

A typical value is 5.0, but the degree should be adapted to the present application.

Valid selections are -99...100. [Per cent]

### **1.4 dt3 - Period in seconds \* 1000 between the readouts of the input value**

The period between the readouts of the input is set both in this menu and in menu 1.5. The total period is the sum of menus 1.4 and 1.5 with the limit of 0.02...3600 seconds.

A typical value is 0, but the period should be adapted to the present application.

Valid selections are 0...003. [Seconds \* 1000]

### **1.5 dt0 - Period in seconds between readouts of the input value**

The period between readouts of the input is set both in this menu and in menu 1.4. The total period is the sum of menus 1.4 and 1.5 with the limit of 0.02...3600 seconds.

A typical value is 1.0, but the period should be adapted to the present application.

Valid selections are 0.02...999. [Seconds]

## **1.0 PAr for analogue multiplexer. [Function no. 16]**

The input that must be transferred to the output must be selected by the digital input.

Input A is selected by deactivating the digital input.

Input B is selected by activating the digital input.

### **1.1 P1 - Scale factor for input A**

A typical value is 1.0.

Valid selections are -99...999. [Factor]

### **1.2 P2 - Scale factor for input B**

A typical value is 1.0.

Valid selections are -99...999. [Factor]

## **2.0 InA - Input A**

The input signal can be inverted by selecting the 0% value greater than the 100% value.

### **2.1 IAL - Setting of 0% input signal**

Valid selections are current 0.0...20.0 [mA], or voltage 0.0...10.0 [VDC].

For modules with a Pt100 input, the valid 0% temperature is -99...+850 [°C].

### **2.2 IAH - Setting of 100% input signal**

Valid selections are current 0.0...20.0 [mA], or voltage 0.0...10.0 [VDC].

For modules with a Pt100 input, the valid 100% temperature is -99...+850 [°C].

### **2.3 UI - Selection of current / voltage input**

To select the current / voltage input the jumper on the PCB must be moved.

For modules with a Pt100 input, this menu has no function.

Possible selections are I - [Current], or U - [Voltage].

## **3.0 Inb - Input B**

The input signal can be inverted by selecting the 0% value greater than the 100% value.

### **3.1 IbL - Setting of 0% input signal**

Valid selections are current 0.0...20.0 [mA], or voltage 0.0...10.0 [VDC].

### **3.2 IbH - Setting of 100% input signal**

Valid selections are current 0.0...20.0 [mA], or voltage 0.0...10.0 [VDC].

### **3.3 UI - Selection of current / voltage input**

To select the current / voltage input the jumper on the PCB must be moved.

Possible selections are I - [Current], or U - [Voltage].

## **4.0 OUt - Output**

The output signal can be inverted by selecting the 0% value greater than the 100% value.

### **4.1 OL - Setting of 0% output signal**

Valid selections are current 0.0...20.0 [mA], or voltage 0.0...10.0 [VDC].

### **4.2 OH - Setting of 100% output signal**

Valid selections are current 0.0...20.0 [mA], or voltage 0.0...10.0 [VDC].

### **4.3 UI - Selection of current or voltage output**

The basic calibration data in the module differ according to the selected output signal range meaning that the current output is current-calibrated, and the voltage output is voltage-calibrated by the internally mounted resistors.



To change between the output voltage in the range 0...1 and 0...10 VDC, the jumper on the PCB must be moved.

Possible selections are:

- 001 = current output in the range 0...10 mA
- 002 = current output in the range 0...20 mA (for instance 4...20 mA)
- 003 = voltage output in the range 0...500 mV
- 004 = voltage output in the range 0...1 V (for instance 0.2...1 V)
- 005 = voltage output in the range 0...5 V
- 006 = voltage output in the range 0...10 V

#### 4.4 Or - Selection of overrange

When ON has been selected, the output can exceed the selected output span by  $\pm 3\%$ , however only within the range 0...20.5 mA / 0...10.25 VDC.

When OFF has been selected, the output is limited to the selected output span.

Possible selections are ON or OFF. [Permit overrange]

## 5.0 APP - Selection of application

### 5.1 FUn - Selection of function

Possible selections are:

- 001 = Addition of 2 analogue signals ( $P1*A + P2*B + P3$ )
- 002 = Subtraction of 2 analogue signals ( $P1*A - P2*B + P3$ ) or ( $P2*B - P1*A + P3$ )
- 003 = Max. selection of 2 analogue signals Max. ( $P1*A, P2*B$ ) +  $P3$
- 004 = Min. selection of 2 analogue signals Min. ( $P1*A, P2*B$ ) +  $P3$
- 005 = Multiplication of 2 analogue signals ( $P1*A*B$ ) +  $P3$
- 006 = Division of 2 analogue signals ( $P1*A/B$ ) +  $P3$  or ( $P1*B/A$ ) +  $P3$
- 007 = Root extraction / Raising to a power ( $P1(A \text{ or } B)^{P2}$ ) +  $P3$

A and B are the input signal spans for the A and B inputs respectively. P1 and P2 are the scale factors multiplied on the A and B inputs respectively. When the scale factors are 1, the input signal is scaled to its full value.

A scale factor of 0.5 will scale the input signal to half its value. At the multiplication, division, root extraction and power functions the scale factor must be set as P1. At the root extraction and raising to a power P2 is the exponent. An exponent of 0.5 will result in a square root function; an exponent of 2 will raise the input to the second power.

P3 is a calculation offset set to values between 0 and 1 (0...100%) and added to the present signal range of the output. If for instance the output is set to a signal range of 10...20 mA, a P3 of 0.5 will result in an extra offset of 50% of the output span. This means that the signal range starts at 15 mA and starts to limit at 20 mA. At most calculations, the calculation

offset must be set to 0, but at complex calculations it can be used for moving the range of the output signal range.

When calculating scale factors the input and output signal spans always have values between 0 and 1. When adding 2 identically scaled input signals of for instance 4...20 mA, the output would be 8...40 mA at the same scaling. But as the output follows standard current signals of 0/4...20 mA, the scaling on the output is double of the scaling on the inputs. This means that each input must be scaled by only half the scale of the output. The figures can be calculated according to the following expression  $(P1*A + P2*B + P3) = 1$ , and with this in mind it will be  $(0.5*1+0.5*1 + 0) = 1$ .

When adding 2 differently scaled input signals, the scale factors can be calculated as follows:

Signal A is 4...20 mA corresponding to a flow of 0...100 m<sup>3</sup> / h

Signal B is 4...20 mA corresponding to a flow of 0...150 m<sup>3</sup> / h

The output signal of 4...20 mA must correspond to a flow of 0...250 m<sup>3</sup> / h

Signal A must be scaled by 100/250 corresponding to a scale factor P1 of 0.4.

Signal B must be scaled by 150/250 corresponding to a scale factor P2 of 0.6.

#### **008 = Sample-Hold**

When the digital input is deactivated, the analogue output follows the selected analogue input (A or B). When the digital input is activated, the output value is fixed at the value it had when activated until the digital input is deactivated. The hold value is saved at power failure.

#### **009 = Peak-Hold**

When the digital input is deactivated, the greatest value (the peak value) of the selected analogue input (A or B) since the latest reset is held. An activated digital input will reset the peak value to the value that the input had when activated. By inverting the input and output signals, the smallest input value is held. The peak value is saved at power failure.

#### **010 = Time delay**

The output follows the values of the selected input (A or B) averaged according to an exponential function.

#### **011 = PID controller**

In a correctly tuned PID controller, the constant error will be eliminated. This means that at a correctly tuned  $X_p$ ,  $T_i$ , and  $T_d$ , a regulation accuracy close to what the process value can be measured to can be obtained. Therefore it is important that the the proportional band  $X_p$ , the

integrating time  $T_i$ , and the differentiating time  $T_d$  are adjusted according to the present application. Before setting the parameter, the method of regulation direct / inverted must be determined. Direct controlling results in an increasing output when the process value is  $>$  the setpoint. Inverted controlling results in a decreasing output when the process value is  $>$  the setpoint. Less experienced users may use the following rule-of-thumb for determining the process parameters:

1. Set  $X_p$  at max.,  $T_i$  and  $T_d$  at 0 (only proportional controlling).
2. Reduce  $X_p$  until the process starts oscillating.
3. Double  $X_p$ .
4. Set  $T_i$  at max.
5. Reduce  $T_i$  until the process starts reoscillating.
6. Double  $T_i$ .
7. If the controller is too slow reaching its setpoint, the differential controller can be activated. The differential function increases the control signal proportionally to the rise time of the process signal. Therefore the setting varies according to the process.

#### **012 = Manual / Automatic controller**

The digital input is used to switch between the manual and automatic mode. A deactivated digital input results in the auto function, where the value of input A is transferred to the output. An activated digital input results in the manual function, where the output adopts the value of input A when activated. Now the output can be activated up or down manually. The output holds the manual setting for an unlimited period. The setting is saved at power failure.

#### **013 = Signal limiter**

The output follows the value of the selected analogue input (A or B) linearly in the range between the min. and max. settings. At input signals smaller than the min. or greater than the max. settings, the output is held on the min. or max. value respectively. The min. or max. value can be set externally via the other analogue input.

#### **014 = Averaging function**

The averaging function reads the input value of the selected A or B channel every 20 ms and adds up the measurements in a memory. When the averaging time has expired, the average value is calculated by dividing the memory value by the number of measurements made, and the output is then updated by this value. The averaging function has 2 parameter settings,  $AtI$  - averaging time, and  $StS$  - number of memories. The averaging time is the time that is averaged. The number of memories to be selected is (1...14). The time between the updates of the output is determined by the average time divided by number of memories ( $AtI/StS$ ). If  $AtI/StS$  is smaller than 20 ms, the output will be updated every 20 ms.

Example:

With an average time of 10 s and 1 memory, the period between the updates of the output will be  $(10/1) = 10$  s. The output will typically make a jump at the update. If the number of memories is for instance 10, the period between the updates of the output will be  $(10/10) = 1$  s. Each memory (1...10) will hold the average value for 1 s. The output is updated every second by the average value of the 10 memories. This means that the jumps on the output will be smaller. The 10 memories will be replaced continuously according to the FIFO method (first in, first out).

### **015 = Slope transmitter (dl / dt function)**

The slope transmitter converts the slope (dl) of input A according to a set period (dt) to an analogue output signal. Each time the set period (dt) has expired, the input value is read. The latest readout is compared to the previous, and the difference between these two values is the slope of the input signal, which is converted to an analogue output signal. The output is updated each time a period (dt) has expired. The slope can be selected as either positive or negative. The input signal can be averaged according to an exponential function so that it can be applied to noisy signals.

Example:

Minimum slope (dIL) = 0%.

Maximum slope (dIH) = -1%.

Period = 5 seconds.

Analogue output = 4...20 mA.

Result:

Has the input value not been changed within 5 seconds, the output will be 4 mA. Has the input value decreased by 0.5% after 5 seconds, the output will be 12 mA. Has the input value decreased by 1% after 5 seconds, the output will be 20 mA.

### **016 = Analogue multiplexer**

Expression:  $(P1 * A)$  and  $(P2 * B)$ .

The input (A or B) to be transferred to the output is selected by the digital input. Input A has been selected when the digital input is deactivated, and input B has been selected when the digital input is activated. P1 and P2 are scale factors multiplied on input A or B respectively. When the scale factor is 1, the input value is scaled to its full value. A scale factor of 0.5 will scale the input signal to half its value.

## 5.2 FrQ - Frequency

Common mode frequency suppression.

Possible selections are 50 or 60. [Hz]

## 5.3 dSP - Default display

The selected span is displayed in per cent. For modules with a Pt100 input, also °C can be displayed.

Possible selections are A or B [Input], OUt [Output], or °C [Temperature].

## 5.4 PAS - Password

When the password is 040, changes can be made in all menu points.

When the password is <> 040, programming is blocked in all menu points but open to a reading of settings.

Valid selections are 0...999. [Password]

## Graphic illustration of functions 1...4

**Addition FUN 001, (A + B)**

$P1 = 0.5, P2 = 0.5, P3 = 0.0$

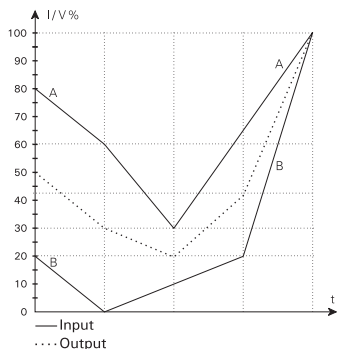

**Subtraction FUN 002, (A - B)**

$P1 = 1.0, P2 = 1.0, P3 = 0.0$

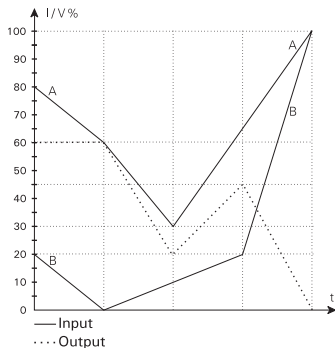

**Max. selection FUN 003, (max. A & B)**

$P1 = 1.0, P2 = 1.0, P3 = 0.0$

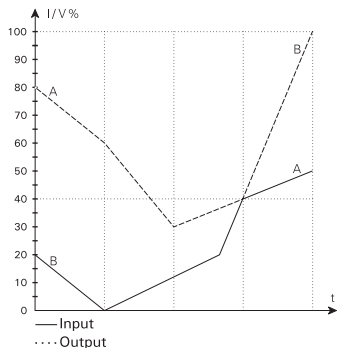

**Min. selection FUN 004, (min. A & B)**

$P1 = 1.0, P2 = 1.0, P3 = 0.0$

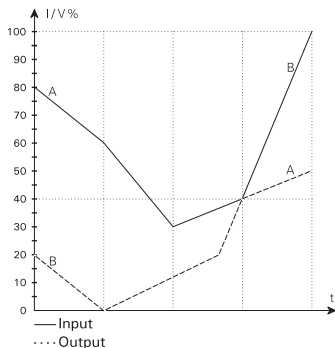

## Graphic illustration of functions 5...8

### Multiplication FUN 005, (A \* B)

P1 = 1.0, P2 = -, P3 = 0.0

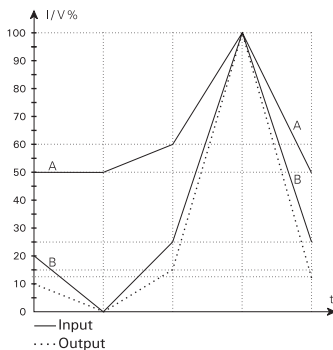

### Division FUN 006, (A / B)

P1 = 1.0, P2 = -, P3 = 0.0, CH = B, HLd = dSA

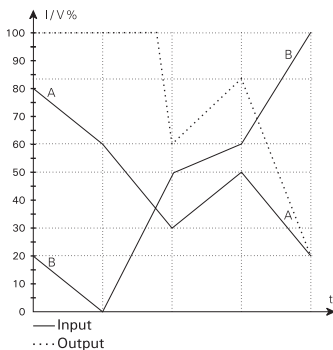

### Root extraction / power FUN 007, ( $\sqrt{A}$ )

P1 = 1.0, P2 = 0.5, P3 = 0.0, CH = A, LCO = 0.5

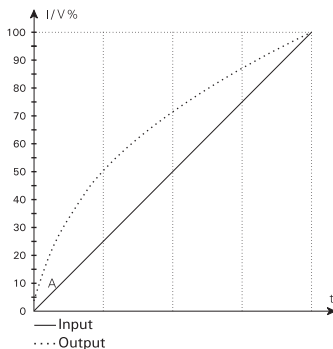

### Hold FUN 008, (A)

P1 = -, P2 = -, P3 = --, CH = A

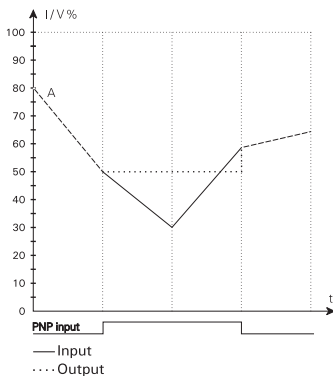

## Graphic illustration of functions 9...12

### Peak FUN 009, (A)

P1 = -, P2 = -, P3 = -, CH = A

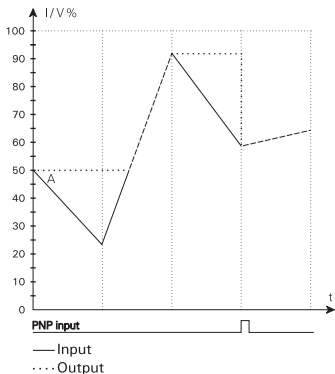

### Delay FUN 010, (A)

tAU = 5.0, CH = A

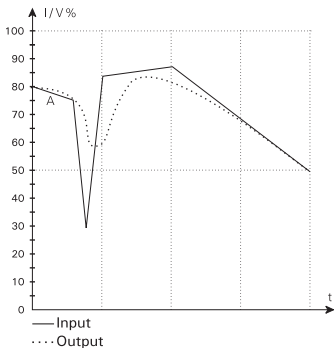

### PID controller FUN 011

SEt = 60.0, hP = 10.0, tI = 5.0, tD = 0.0  
IE = I, dI = lnU, dIF = OFF, PUP = rES

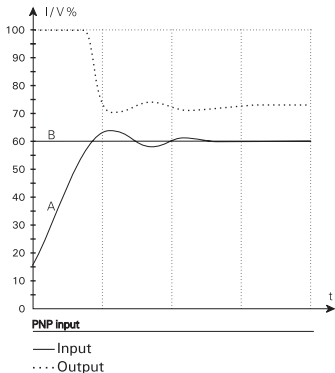

### Man. / auto controller FUN 012

StP = 5.0, IE = I, dIF = lnP

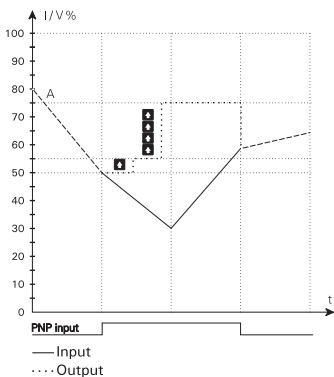



## Graphic illustration of functions 13...16

**Signal limiter FUN 013, ( A )**

IL = 10.0, IH = 85.0, CH = A

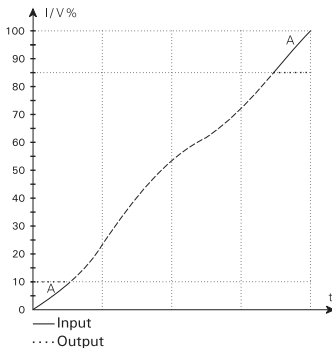

**Averaging FUN 014, ( A )**

AtI = 5.0, StS = 1.0, CH = A

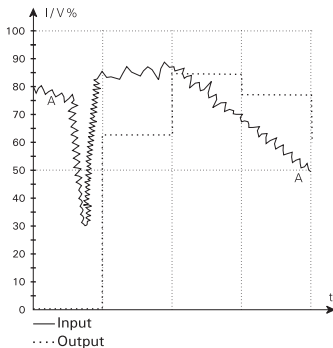

**Slope transmitter FUN 015, ( A )**

tAU = 0.0, dIL = 0.0, dIH = 10.0  
dt3 = 0.0, dt0 = 1.0

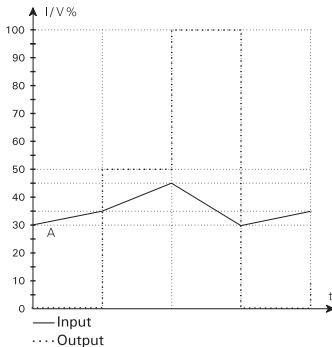

**Analogue multiplexer FUN 016**

P1 = 1.0, P2 = 1.0

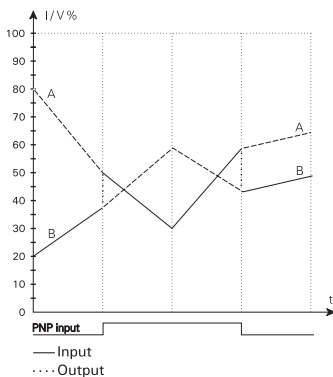



**Displays** Programmable displays with a wide selection of inputs and outputs for display of temperature, volume and weight, etc. Feature linearization, scaling, and difference measurement functions for programming via PReset software.



**Ex interfaces** Interfaces for analog and digital signals as well as HART signals between sensors / I/P converters / frequency signals and control systems in Ex zone 0, 1 & 2 and for some devices in zone 20, 21 & 22.



**Isolation** Galvanic isolators for analog and digital signals as well as HART signals. A wide product range with both loop-powered and universal isolators featuring linearization, inversion, and scaling of output signals.







**Temperature** A wide selection of transmitters for DIN form B mounting and DIN rail devices with analog and digital bus communication ranging from application-specific to universal transmitters.





**Universal** PC or front programmable devices with universal options for input, output and supply. This range offers a number of advanced features such as process calibration, linearization and auto-diagnosis.









  [www.preelectronics.fr](http://www.preelectronics.fr)  
 [sales-fr@preelectronics.com](mailto:sales-fr@preelectronics.com)



  [www.preelectronics.de](http://www.preelectronics.de)  
 [sales-de@preelectronics.com](mailto:sales-de@preelectronics.com)



  [www.preelectronics.es](http://www.preelectronics.es)  
 [sales-es@preelectronics.com](mailto:sales-es@preelectronics.com)



  [www.preelectronics.it](http://www.preelectronics.it)  
 [sales-it@preelectronics.com](mailto:sales-it@preelectronics.com)

  [www.preelectronics.se](http://www.preelectronics.se)  
 [sales-se@preelectronics.com](mailto:sales-se@preelectronics.com)

  [www.preelectronics.com](http://www.preelectronics.com)  
 [sales-uk@preelectronics.com](mailto:sales-uk@preelectronics.com)

  [www.preelectronics.com](http://www.preelectronics.com)  
 [sales-us@preelectronics.com](mailto:sales-us@preelectronics.com)

  [www.preelectronics.cn](http://www.preelectronics.cn)  
 [sales-cn@preelectronics.com](mailto:sales-cn@preelectronics.com)

  [www.preelectronics.be](http://www.preelectronics.be)  
 [sales-be@preelectronics.com](mailto:sales-be@preelectronics.com)

## Head office

Denmark  
PR electronics A/S  
Lerbakken 10  
DK-8410 Rønnde

[www.preelectronics.com](http://www.preelectronics.com)  
[sales-dk@preelectronics.com](mailto:sales-dk@preelectronics.com)  
tel. +45 86 37 26 77  
fax +45 86 37 30 85



QUALITY SYSTEM AND ENVIRONMENTAL  
MANAGEMENT SYSTEM  
DS/EN ISO 9001  
DS/EN ISO 14001

